

SAMSUNG

SAC

Technical

Data Book

Accessories Book for
Global

1. MCU (Mode Control Unit)
2. EEV (Electronic Expansion Valve) kit
3. AHU (Air Handling Unit) kit
4. FCU (Fan Coil Unit) Kit
5. UCK (Universal Communication Kit)
6. Drain Pumps
7. Low Ambient Cooling kit (For North America)
8. PDM (Pressure Drop Modulation) Kit
9. Branch kit
10. ERV Kit (Modbus Interface Module, For North America only)
11. Differential Pressure Switch(for Europe only)
12. MERV Filter MF-C6A0 for North America 4Way Cassette



History

Version	Modification	Date	Remark
Ver1.0	Release the accessory TDB for global	16. 02. 23	
Ver1.1	Modification for AHU kit - Spec. separation of MXD-A64K100E from MCM-D201N (p.36) - Add parts and component for MCM-D201N and MXD-A64K100E (p.38) - Add electrical wiring diagram for MCM-D201N (p.40)	16. 07. 12	
Ver1.2	Revision all description	16. 10. 25	
Ver1.3	Modification for Panel of Mini 4way Cassette - Add New Panel Line-up Modification for MCU (Mode Control Unit) (Add line-up) Add to FCU (Fan Coil control) kit Add to UCK (Universal communication kit)	16. 12. 16	
Ver1.4	Modification for VOC - Add to US system of units - Delete models of not available	17. 05. 08	
Ver2.0	Add for New Accessory (Single AHU Kit)	17. 09. 28	
Ver. 3.0	Release New Accessory TDB Version 2018	18. 06. 31	
Ver 3.1	Add New Accessory (MERV Filter for N.A 4Way Cassette)	18. 12. 22	
Ver 4.0	Release New Accessory TDB Version 2021	20. 12. 28	
Ver 4.1	Updated the Indoor unit's Capacity of EEV (Electronic Expansion Valve) kit	21. 06. 02	
Ver 4.2	Updated the MCU Spec page	22. 01. 27	

Contents

1. MCU (Mode Control Unit)	4
2. EEV (Electronic Expansion Valve) kit	31
3. AHU (Air Handling Unit) kit	40
4. FCU (Fan Coil Unit) Kit	49
5. UCK (Universal Communication Kit)	57
6. Drain Pumps	69
7. Low Ambient Cooling kit (This optional kit is sold only in North America)	79
8. PDM (Pressure Drop Modulation) Kit	94
9. Branch kit	97
10. ERV Kit Modbus Interface Module, (This optional kit is sold only in North America)	103
11. Differential Pressure Switch (This optional kit is sold only in Europe)	111
12. MERV Filter MF-C6A0 for North America 4Way Cassette	119
13. Accessory Compatibility	126

1. MCU (Mode Control Unit)

1.1 Feature

Fine-tuned control

DVM S HR uses a Mode Change Unit (MCU) kit that is less than 32 percent the size of competitors' products. The MCU has an internal on/off valve that enables fine-tuned control via an electronic expansion valve (EEV) and sub-cooler. Improved performance and reduced noise create a pleasant temperature-controlled environment.

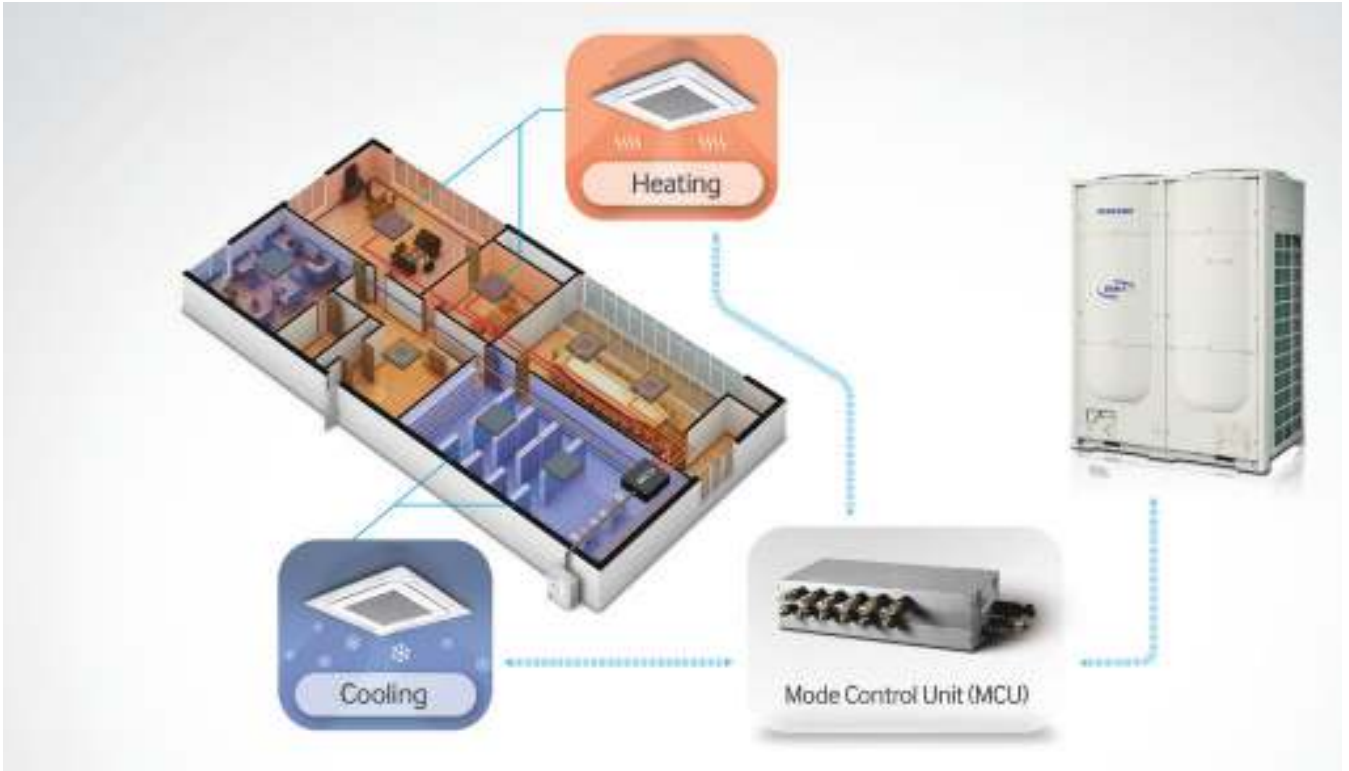

Before installing MCU, refer to the compatible table below and find the model before installation.

Outdoor Unit		MCU		Indoor Unit
AMXXXXXXXXXX	↔	MCU-S6NEE1N MCU-S4NEE1N MCU-S4NEE2N MCU-S2NEK1N MCU-S6NEK2N MCU-S4NEK3N MCU-S2NEK2N MCU-S1NEK1N	↔	AMXXXXNXXXX

1. MCU (Mode Control Unit)

1.1 Feature - For DVM S Eco Only

Fine-tuned control

DVM S Eco uses a HR Changer that is less than 32 percent the size of competitors' products. The MCU has an internal on/off valve that enables fine-tuned control via an electronic expansion valve (EEV) and sub-cooler. Improved performance and reduced noise create a pleasant temperature-controlled environment.

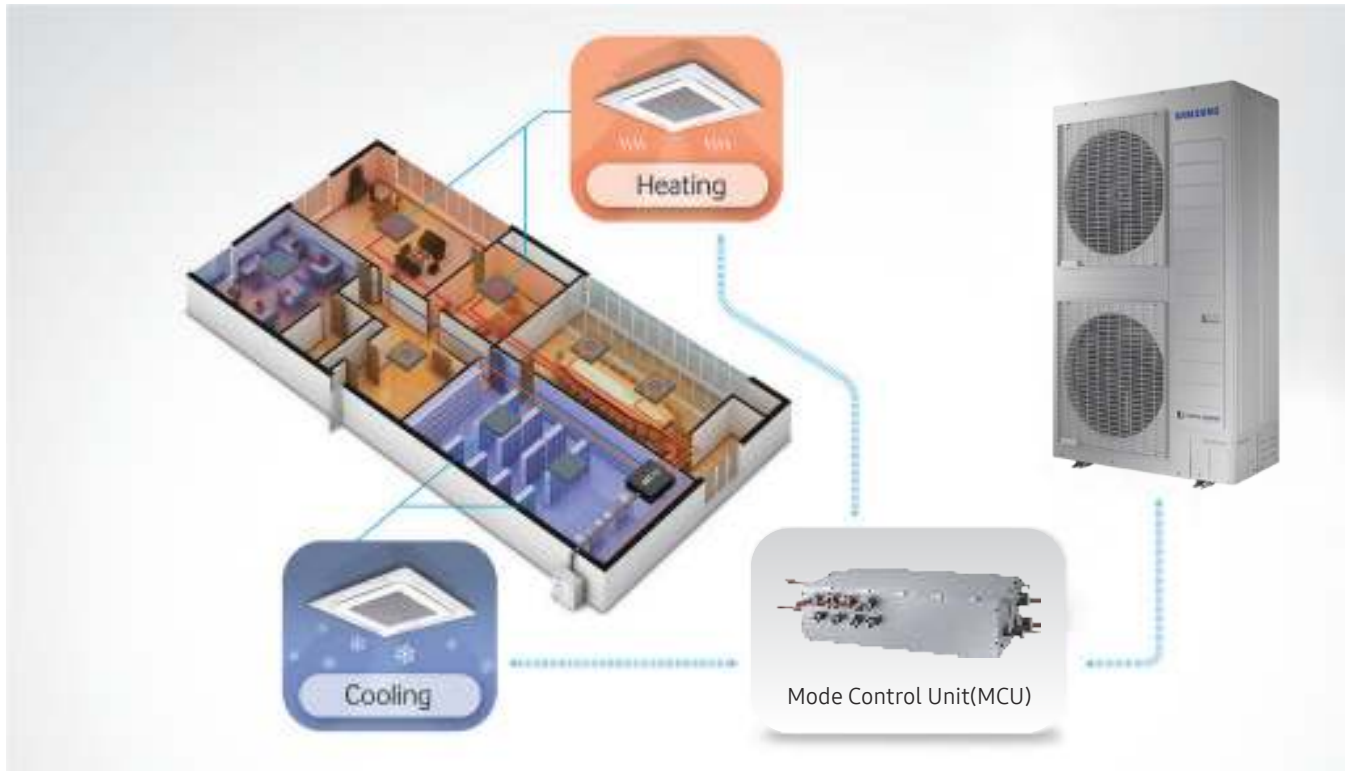

Before installing MCU, refer to the compatible table below and find the model before installation.

Outdoor Unit	HR Changer	Sub MCU	Indoor Unit
AM***XMD*R	MCU-R4NEK0N	MCU-S6NEK3N MCU-S6NEK2N MCU-S4NEK3N MCU-S2NEK2N MCU-S1NEK1N	AM***N***

1. MCU (Mode Control Unit)

1.2. MCU indoor/outdoor unit compatible table

Before installing MCU, refer to the compatible table below and find the model before installation.

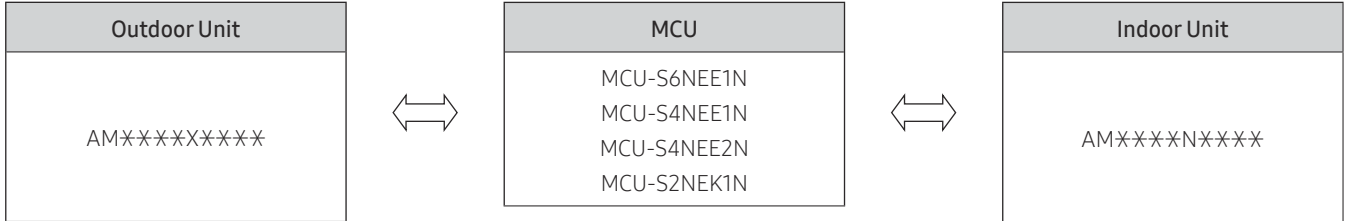

Product	Model	Product size	Remark
MCU kit	MCU-S6NEE1N	Below 6 indoor units, below 56 kW (192MBH)	
	MCU-S4NEE1N	Below 4 indoor units, below 56 kW (192MBH)	
	MCU-S4NEE2N	Below 2 large capacity indoor unit, below 56 kW (192MBH)	
	MCU-S2NEK1N	Below 2 indoor units, below 28 kW (96MBH)	

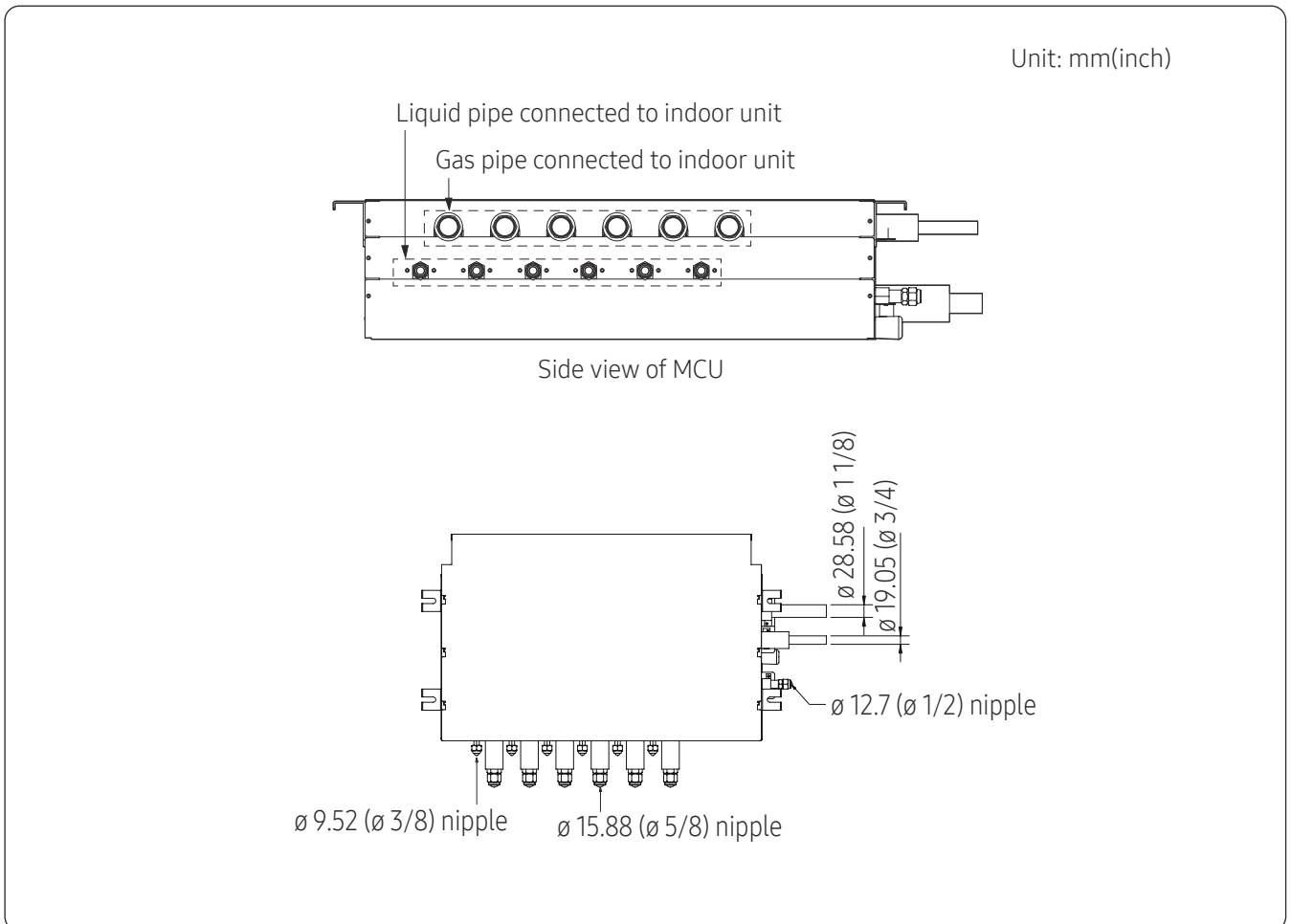

1. MCU (Mode Control Unit)

1.2. MCU indoor/outdoor unit compatible table

Before installing MCU, refer to the compatible table below and find the model before installation.

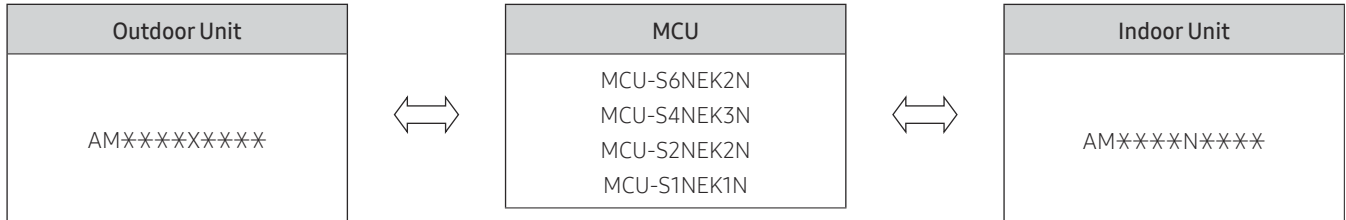

Product	Model	Description
MCU kit	MCU-S6NEK2N	Below 61.6 kW (216MBH)
	MCU-S4NEK3N	Below 61.6 kW (216MBH)
	MCU-S2NEK2N	Below 32 kW (108MBH)
	MCU-S1NEK1N	Below 16 kW (54MBH)

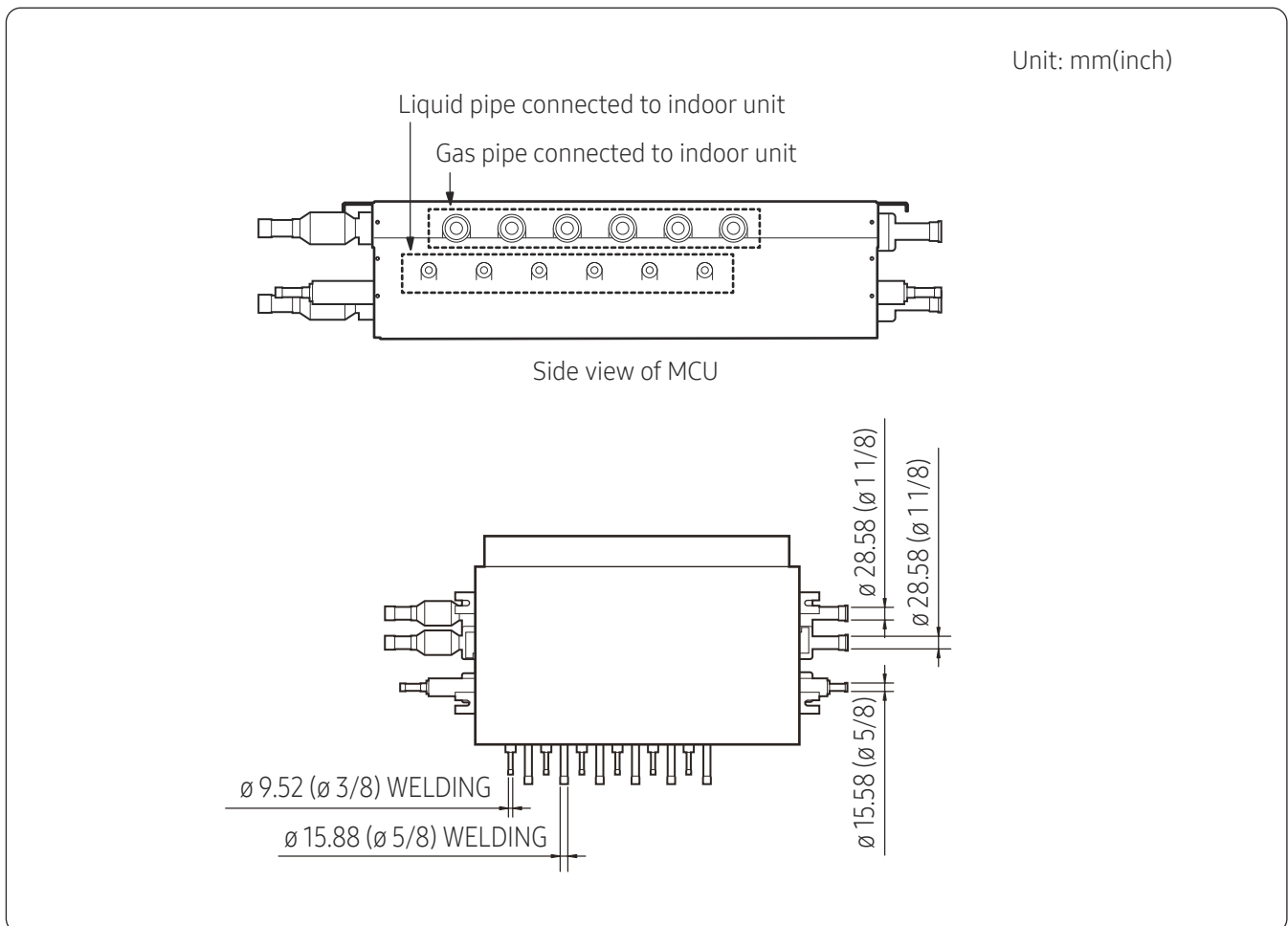

1. MCU (Mode Control Unit)

1.2. HR Changer, MCU indoor/outdoor unit compatible table - For DVM S Eco Only

Before installing HR Changer and Sub MCU, refer to the compatible table below and find the model.

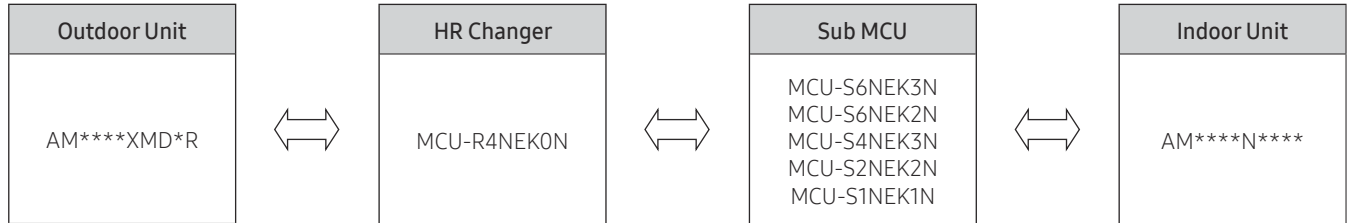

Product	Model	Description
HR Changer	MCU-R4NEK0N	Below 22.4 kW (76MBH)
Sub MCU Kit	MCU-S6NEK3N	Below 22.4 kW (76MBH)

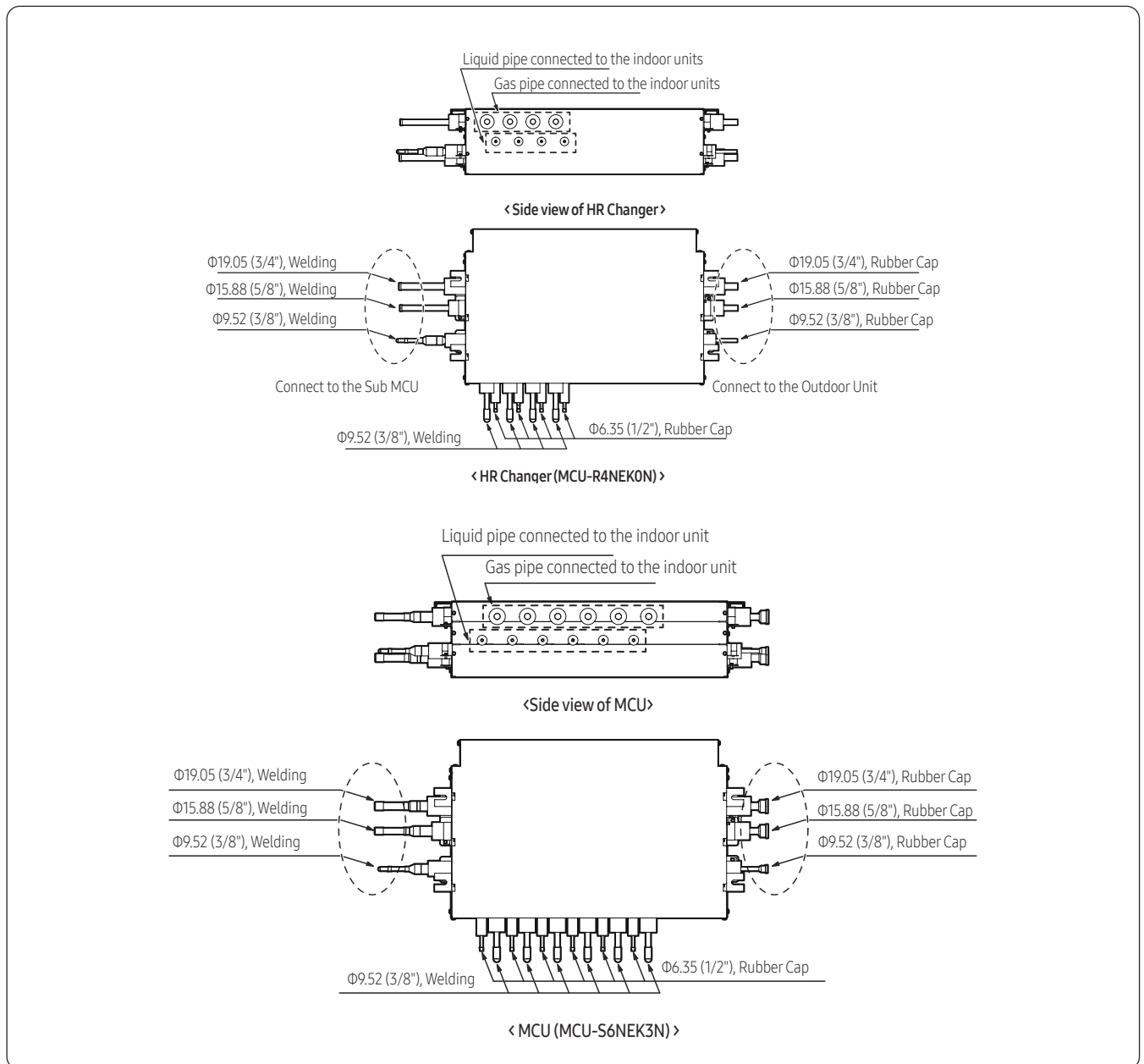

1. MCU (Mode Control Unit)

1.3. Spec Sheet

Type			MCU				
Model			MCU-S6NEE1N	MCU-S4NEE1N	MCU-S4NEE2N	MCU-S2NEK1N	
Maximum number of connectable indoor units	EA		6	4	2	2	
Maximum capacity of connectable indoor units	KW		56	56	56	28	
	MBH		192	192	192	96	
Power Supply	Ø, #, V, Hz		1/2/220-240/50				
			1/2/208-230/60				
Mode	-		heat Recovery				
Power	Power Input (Nominal)	Cooling	W	55	55	55	55
		Heating		55	55	55	55
	Current Input (Nominal)	Cooling	A	0.5	0.5	0.5	0.5
		Heating		0.5	0.5	0.5	0.5
	MCA	A	0.63	0.63	0.63	0.63	
MFA(MOP)	A	15	15	15	15		
Field Wiring	Power Source Wire	mm ²	2.5	2.5	2.5	2.5	
	Transmission Cable	mm ²	Min 0.75	Min 0.75	Min 0.75	Min 0.75	
Sound level	Sound pressure	dB(A)	34	34	34	34	
Piping Connections	Outdoor unit	Liquid Pipe	Ø, mm	12.7	12.7	12.7	12.7
			Ø, inch	1/2	1/2	1/2	1/2
		Gas Pipe	Ø, mm	28.58	28.58	28.58	28.58
			Ø, inch	1 1/8	1 1/8	1 1/8	1 1/8
	Indoor unit	Discharge gas	Ø, mm	19.05	19.05	19.05	19.05
			Ø, inch	3/4	3/4	3/4	3/4
		Liquid Pipe	Ø, mm	9.52	9.52	9.52	9.52
			Ø, inch	3/8	3/8	3/8	3/8
Gas Pipe	Ø, mm	15.88	15.88	19.05	19.05		
	Ø, inch	5/8	5/8	3/4	3/4		
External Dimension	Net Weight	kg (lbs)	27 (59.5)	24 (52.9)	24 (52.9)	21 (46.3)	
	Shipping Weight	kg (lbs)	33.5 (73.9)	29 (63.9)	29 (63.9)	25 (55.1)	
	Net Dimensions (WxHxD)	mm	728 x 469 x 199 [2'-4 3/4"] x [1'-6 1/2"] x [7 3/4"]				
	Shipping Dimensions (WxHxD)	mm	973 x 250 x 631 [3'-2 1/4"] x [9 3/4"] x [2'-0 3/4"]				
Operation Limit	Cooling	°C (°F)	-15~48 (5~118.4)	-15~48 (5~118.4)	-15~48 (5~118.4)	-15~48 (5~118.4)	
	Heating	°C (°F)	-25~24 (-13~75.2)	-25~24 (-13~75.2)	-25~24 (-13~75.2)	-25~24 (-13~75.2)	
Installation	Indoor unit's Capacity		1 port: Below 10kW (30MBH)		2 ports: 11.2 ~ 28kW (36 ~ 96MBH)	1 port: Below 14kW (48MBH)	
			2 port: 11.2 ~ 14kW (36 ~ 48MBH)			2 port: 14 ~ 28kW (48 ~ 96MBH)	
	-15 °C operation		1 port: Below 5kW (18MBH)			* 1 port: Below 5kW (18MBH)	
			2 ports: 5 ~ 14kW (18 ~ 48MBH)			* 2 ports: 5 ~ 28kW (18 ~ 96MBH)	
* The outdoor unit's PCB should be set for -15 °C (5°F) cooling operation.							
* When joining two ports in the MCU, use Y-connector(liquid, gas) offered.							
* 2 ports MCU don't have Y-joint.							

1. MCU (Mode Control Unit)

1.3. Spec Sheet

Type			MCU (GLOBAL)				
Model Name			MCU-S1NEK1N	MCU-S2NEK2N	MCU-S4NEK3N	MCU-S6NEK2N	
Power Supply			Φ, #, V, Hz				
Mode			-	Heat Recovery	Heat Recovery	Heat Recovery	
Power	Power Input (Nominal)	Cooling	W	19.0	25.0	40.0	55.0
		Heating	W	19.0	25.0	40.0	55.0
	Current Input (Nominal)	Cooling	A	0.2A	0.2A	0.2A	0.3A
		Heating	A	0.2A	0.2A	0.2A	0.3A
	MCA		A	2A	2A	2A	2A
	MFA (MOP)		A	15A	15A	15A	15A
Maximum number of connectable indoor units			EA	8	16	32	32
Maximum number of connectable indoor unit per branch			EA	8	8	8	8
Number of branches			EA	1	2	4	6
Maximum capacity of connectable indoor units			Btu/h / kW	54,000 / 16.0	108,000 / 32.0	216,000 / 61.6	216,000 / 61.6
Maximum capacity of connectable indoor units per branch			-	Btu/h / kW	54,000 / 16.0	54,000 / 16.0	54,000 / 16.0
			Y-Joint	Btu/h / kW	-	108,000 / 32.0	108,000 / 32.0
Field Wiring	Power Source Wire		mm ²	2.5	2.5	2.5	2.5
	Transmission Cable		mm ²	0.75~1.5	0.75~1.5	0.75~1.5	0.75~1.5
Sound Pressure	Stable cooling Operation		dB(A)	33	34	36	36
	Heating-to-Cooling Change over		dB(A)	50	50	50	50
Additional refrigerant charging			kg/unit	0.5	0.5	0.5	0.5
Piping Connections	Outdoor unit	Liquid Pipe	Φ, mm	9.52	15.88	15.88	15.88
			Φ, inch	3/8	5/8	5/8	5/8
		Gas Pipe	Φ, mm	22.22	28.58	28.58	28.58
			Φ, inch	7/8	11/8	11/8	11/8
		Discharge gas	Φ, mm	19.05	28.58	28.58	28.58
			Φ, inch	3/4	11/8	11/8	11/8
	Indoor unit	Liquid Pipe	Φ, mm	9.52	9.52	9.52	9.52
			Φ, inch	3/8	3/8	3/8	3/8
		Gas Pipe	Φ, mm	15.88	15.88	15.88	15.88
			Φ, inch	5/8	5/8	5/8	5/8
External Dimension	Net Weight		kg (lbs)	11 (24.3)	21 (46.3)	24.5 (54.0)	28.5 (62.8)
	Shipping Weight		kg (lbs)	13.3 (29.3)	24.3 (53.6)	28.5 (62.8)	32.5 (71.7)
	Net Dimensions (WxHxD)		mm	338 x 409 x 199 [1'-1 1/4"] x [7 7/8"] x [1'-4"]	728 x 469 x 199 [2'-4 5/8"] x [1'-6 4/16"] x [7 7/8"]		
	Shipping Dimensions (WxHxD)		mm	628 x 586 x 252 [2'] x [1'-11"] x [9 3/4"]	1140 x 628 x 252 [3'-7 1/2"] x [2-3/4"] x [9 3/4"]		
Operation Limit	Cooling		°C (°F)	-15~48 (5~118.4)	-15~48 (5~118.4)	-15~48 (5~118.4)	-15~48 (5~118.4)
	Heating		°C (°F)	-25~24(-13~75.2)	-25~24(-13~75.2)	-25~24(-13~75.2)	-25~24(-13~75.2)
Installation	-15 °C operation			1port :Below 5 kW (17MBH)	1port :Below 5 kW (17MBH)	1port :Below 5 kW (17MBH)	1port :Below 5 kW (17MBH)
				2port : 5~16 kW (17~54MBH)	2port : 5~16 kW (17~54MBH)	2port : 5~16 kW (17~54MBH)	2port : 5~16 kW (17~54MBH)
	The outdoor unit's PCB should be set for -15°C (5°F) cooling operation.						
	When joining 2 ports in the MCU, use Y-joint (Liquid, Gas) offered.						
1&2 ports MCU don't have Y-joint							

1. MCU (Mode Control Unit)

1.3. Spec Sheet - For DVM S Eco Only

Type			HR Changer	Sub MCU (GLOBAL)	
Model Name			MCU-R4NEK0N	MCU-S6NEK3N	
Power Supply		Φ, #, V, Hz	1/220-240/50-60	1/220-240/50-60	
Mode		-	Heat Recovery	Heat Recovery	
Power	"Power Input (Nominal)"	Cooling	W	40.0	55.0
		Heating	W	40.0	55.0
	"Current Input (Nominal)"	Cooling	A	0.2A	0.3A
		Heating	A	0.2A	0.3A
	MCA	A	2A	2A	
MFA (MOP)	A	15A	15A		
Maximum number of connectable indoor units		EA	12	18	
Maximum number of connectable indoor unit per branch		EA	3	3	
Number of branches		EA	4	6	
Maximum capacity of connectable indoor units		Btu/h / kW	76,000 / 22.4	76,000 / 22.4	
Maximum capacity of connectable indoor units per branch	-	Btu/h / kW	19,000 / 5.6	19,000 / 5.6	
	Y-Joint	Btu/h / kW	48,000 / 14.0	48,000 / 14.0	
Field Wiring	Power Source Wire		mm2	2.5	2.5
	Transmission Cable		mm2	0.75~1.5	0.75~1.5
Sound Pressure	Stable cooling Operation		dB(A)	34	36
	Heating-to-Cooling Change over		dB(A)	50	50
Additional refrigerant charging		kg/unit	0.5	0.5	
Piping Connections	Outdoor unit	Liquid Pipe	Φ, mm	9.52	9.52
			Φ, inch	3/8	3/8
		Gas Pipe	Φ, mm	19.05	19.05
			Φ, inch	3/4	3/4
		Discharge gas	Φ, mm	15.88	15.88
			Φ, inch	5/8	5/8
	Indoor unit	Liquid Pipe	Φ, mm	6.35	6.35
			Φ, inch	1/4	1/4
		Gas Pipe	Φ, mm	12.7	12.7
			Φ, inch	1/2	1/2
Drain		Φ, mm	-	-	
External Dimension	Net Weight		kg (lbs)	21.3 (46.96)	24.3 (53.58)
	Shipping Weight		kg (lbs)	24.9 (54.90)	27.9 (61.51)
	Net Dimensions (WxHxD)		mm	728 x 199 x 469	728 x 199 x 469
	Shipping Dimensions (WxHxD)		mm	1140 x 252 x 628	1140 x 252 x 628
Operation Limit		Cooling	°C (°F)	-15~48 (5~118.4)	-15~48 (5~118.4)
		Heating	°C (°F)	-25~24 (-13~75.2)	-25~24 (-13~75.2)

1. MCU (Mode Control Unit)

1.4. Technical drawings

Dimensional drawings

MCU-S2NEK1N

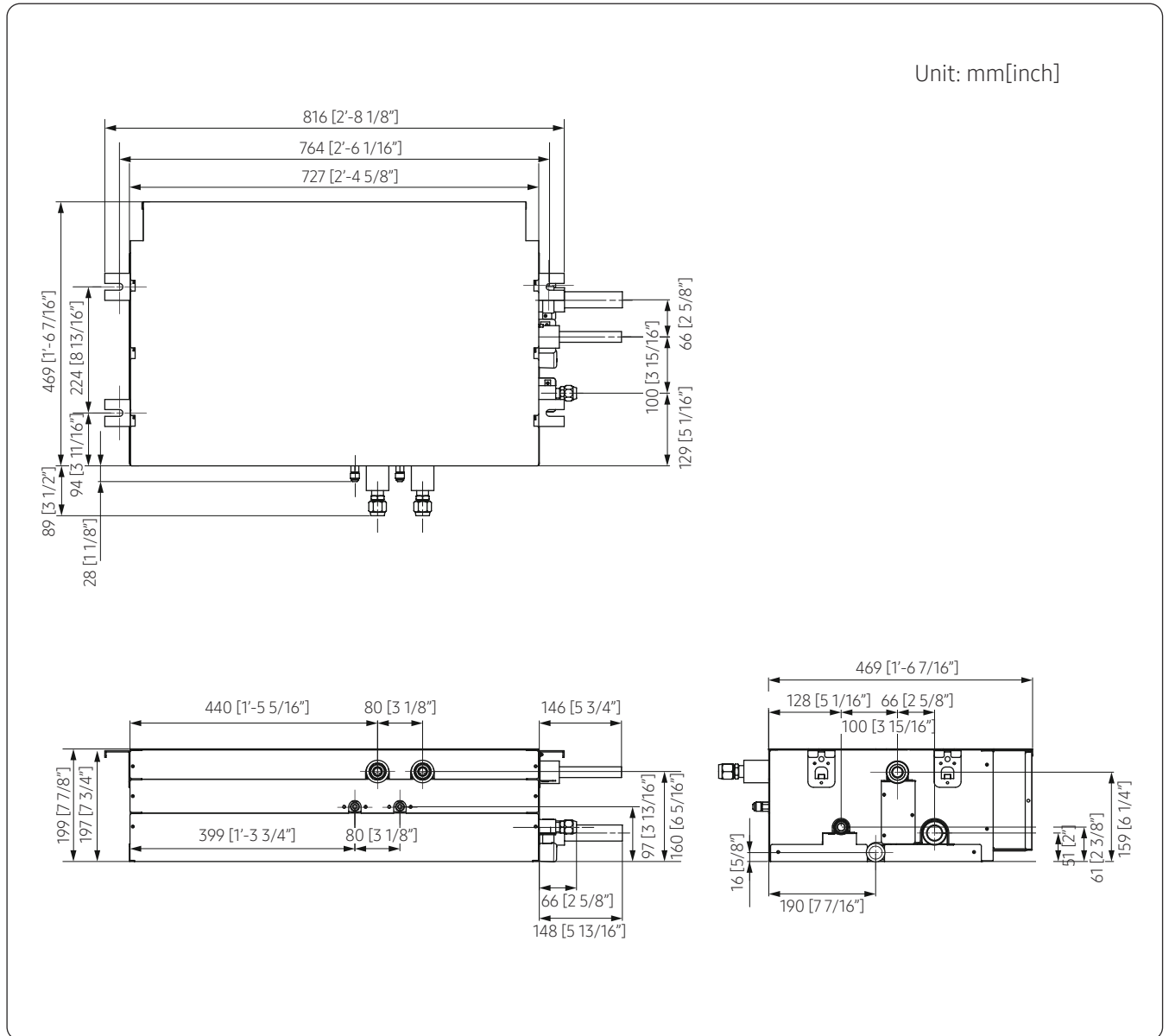

1. MCU (Mode Control Unit)

1.4. Technical drawings

MCU-S4NEE1N / MCU-S4NEE2N

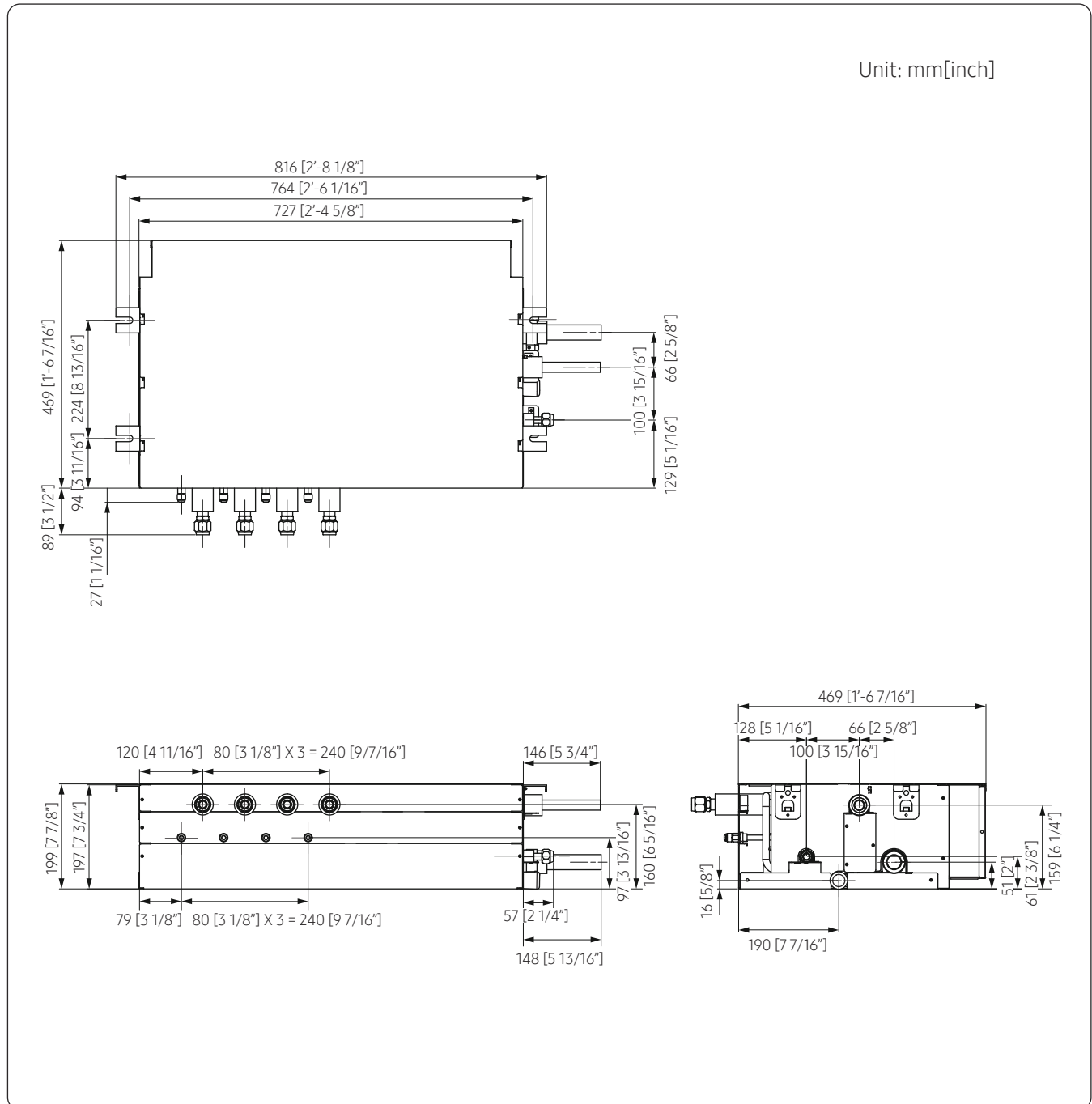

1. MCU (Mode Control Unit)

1.4. Technical drawings

MCU-S6NEE1N

Unit: mm[inch]

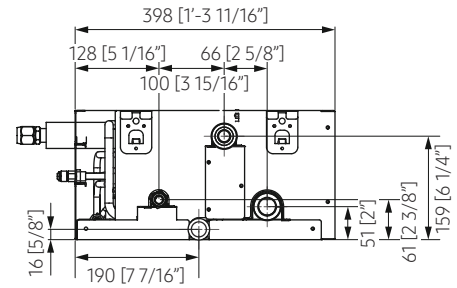
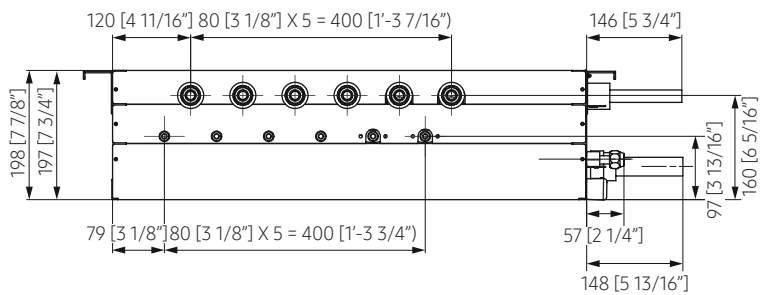
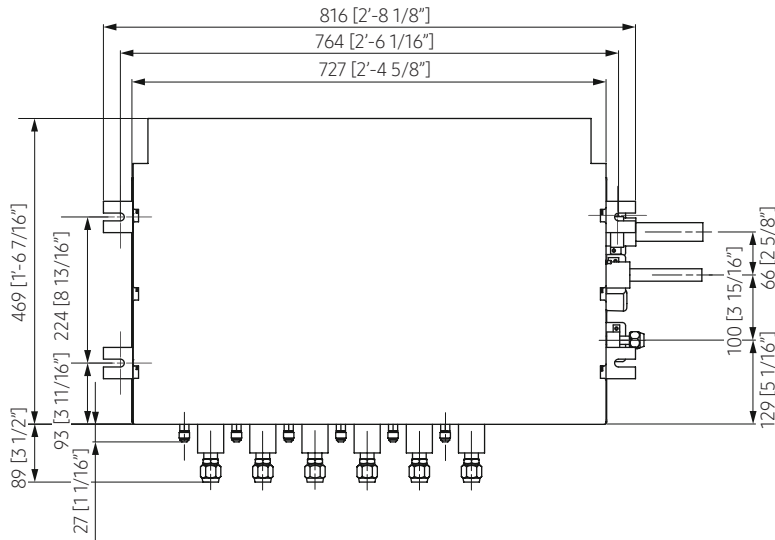

1. MCU (Mode Control Unit)

1.4. Technical drawings

MCU-S1NEK1N

Unit: mm[inch]

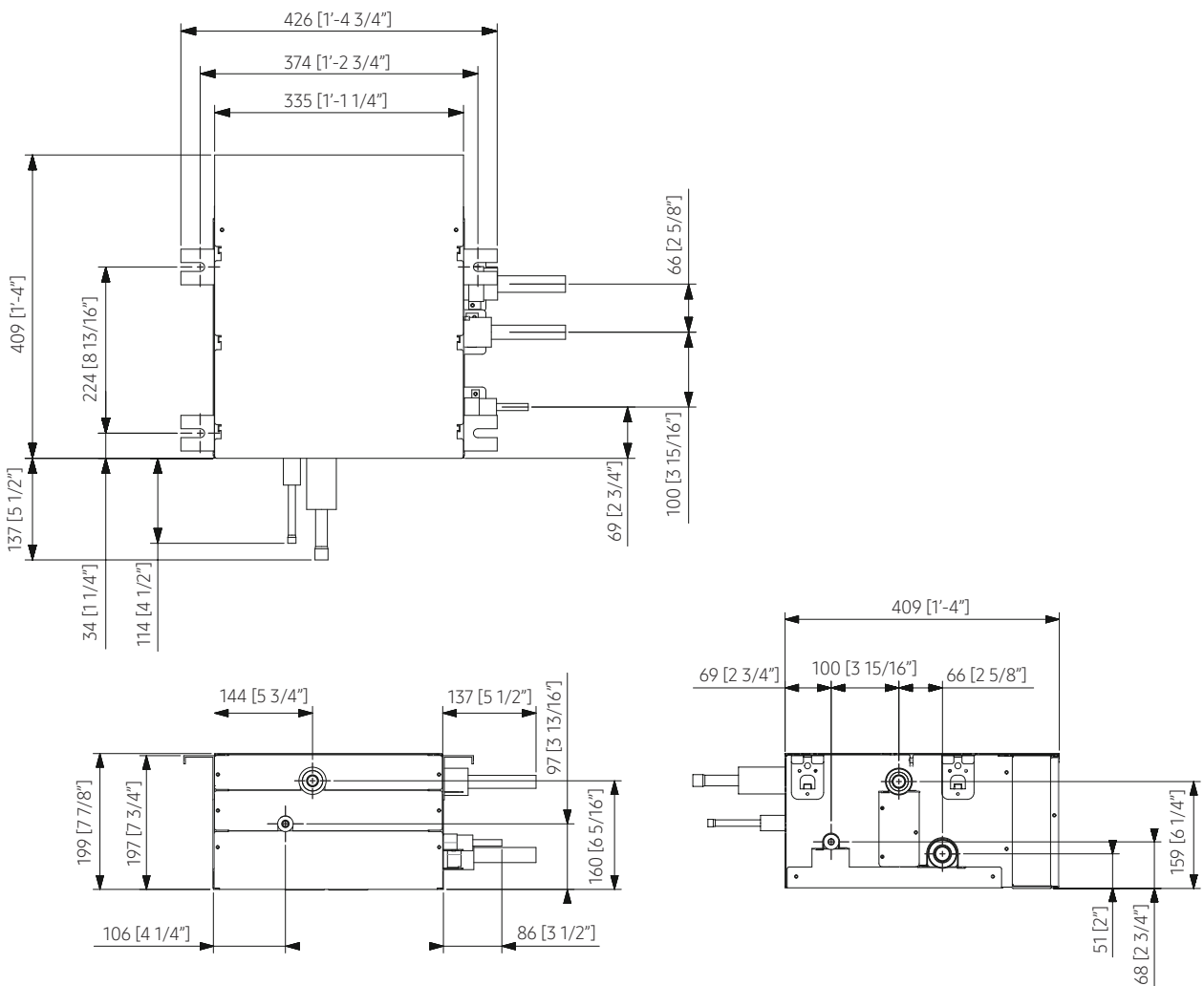

1. MCU (Mode Control Unit)

1.4. Technical drawings

MCU-S2NEK2N

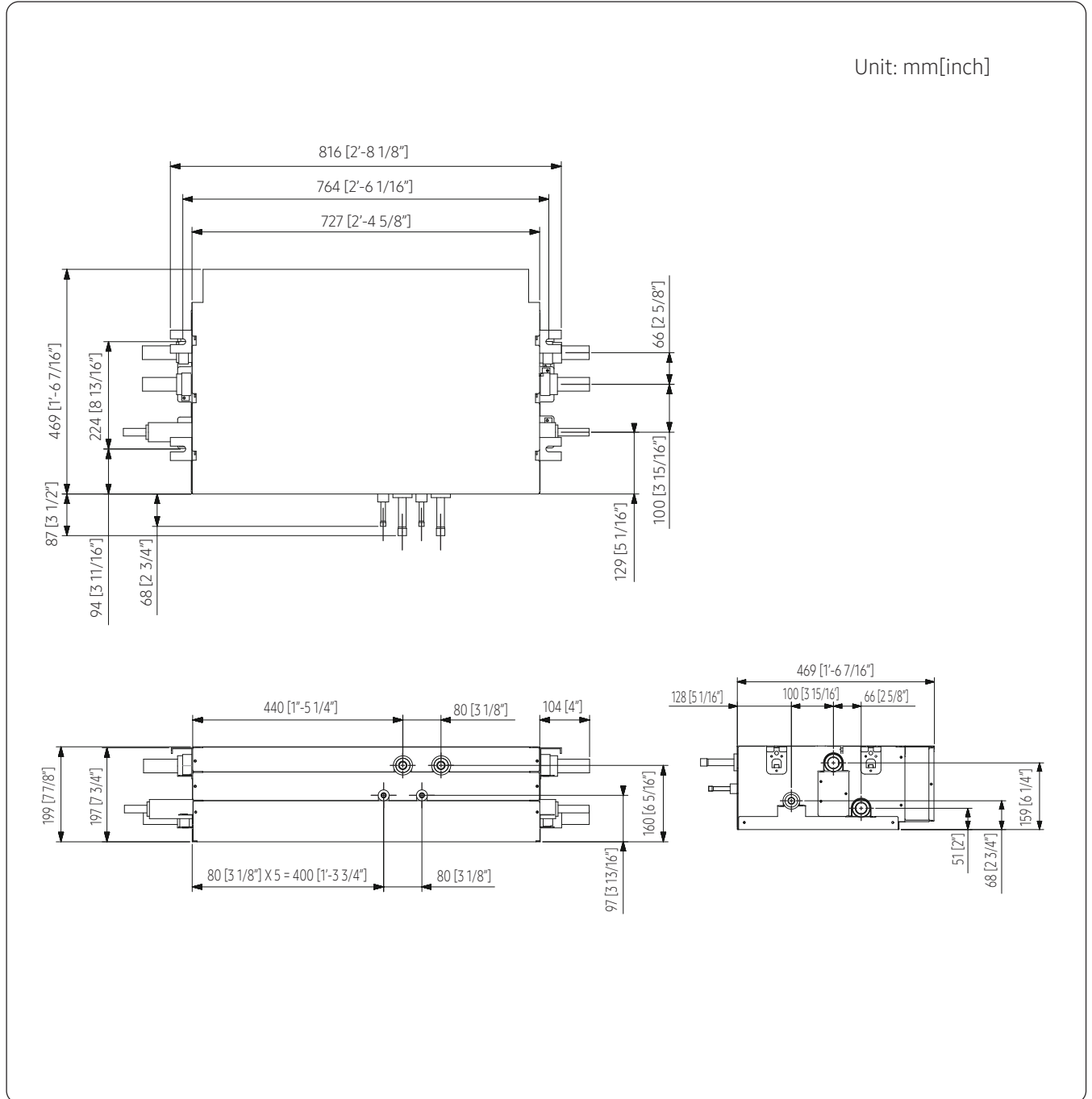

1. MCU (Mode Control Unit)

1.4. Technical drawings

MCU-S4NEK3N

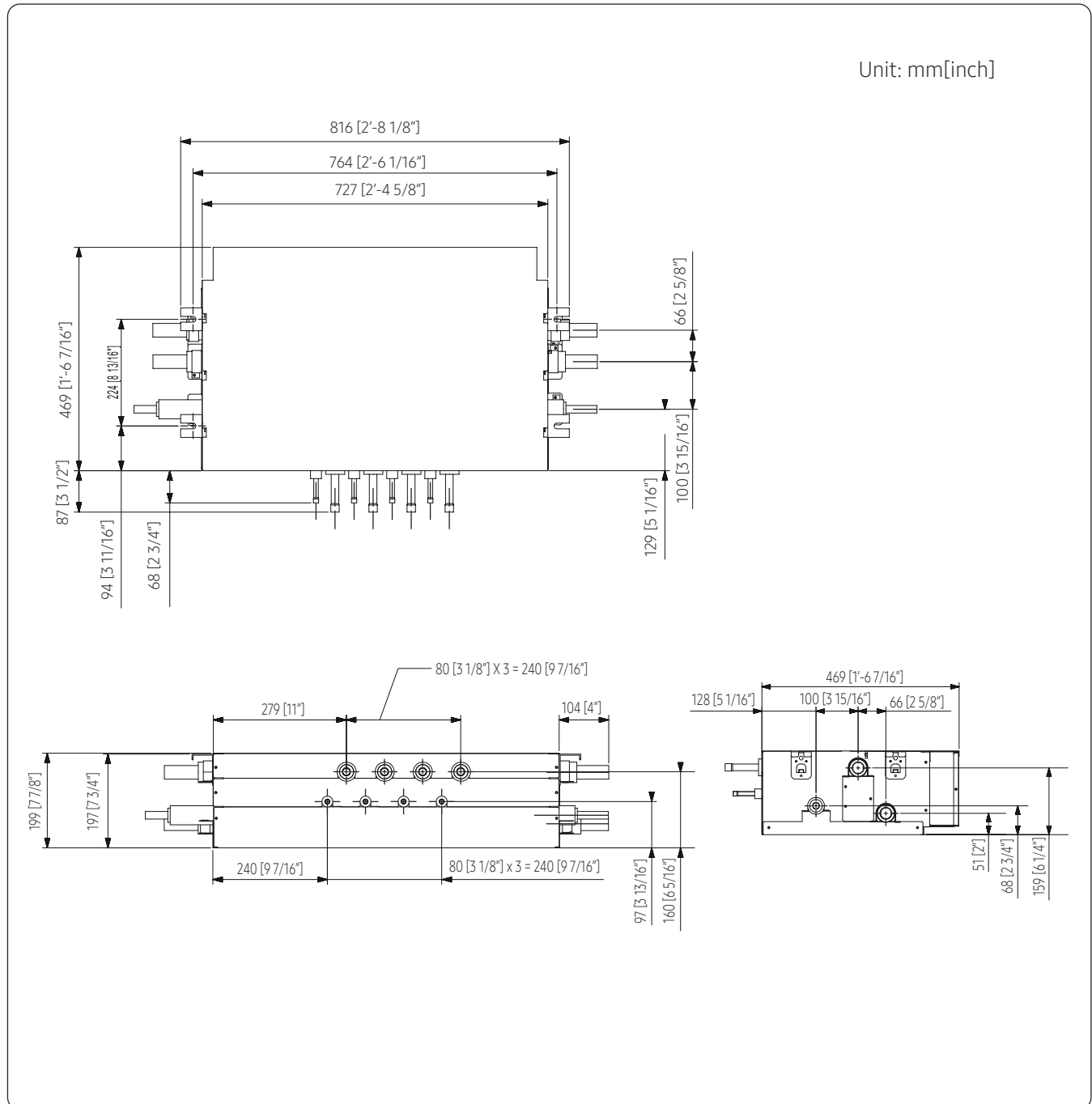

1. MCU (Mode Control Unit)

1.4. Technical drawings

MCU-S6NEK2N

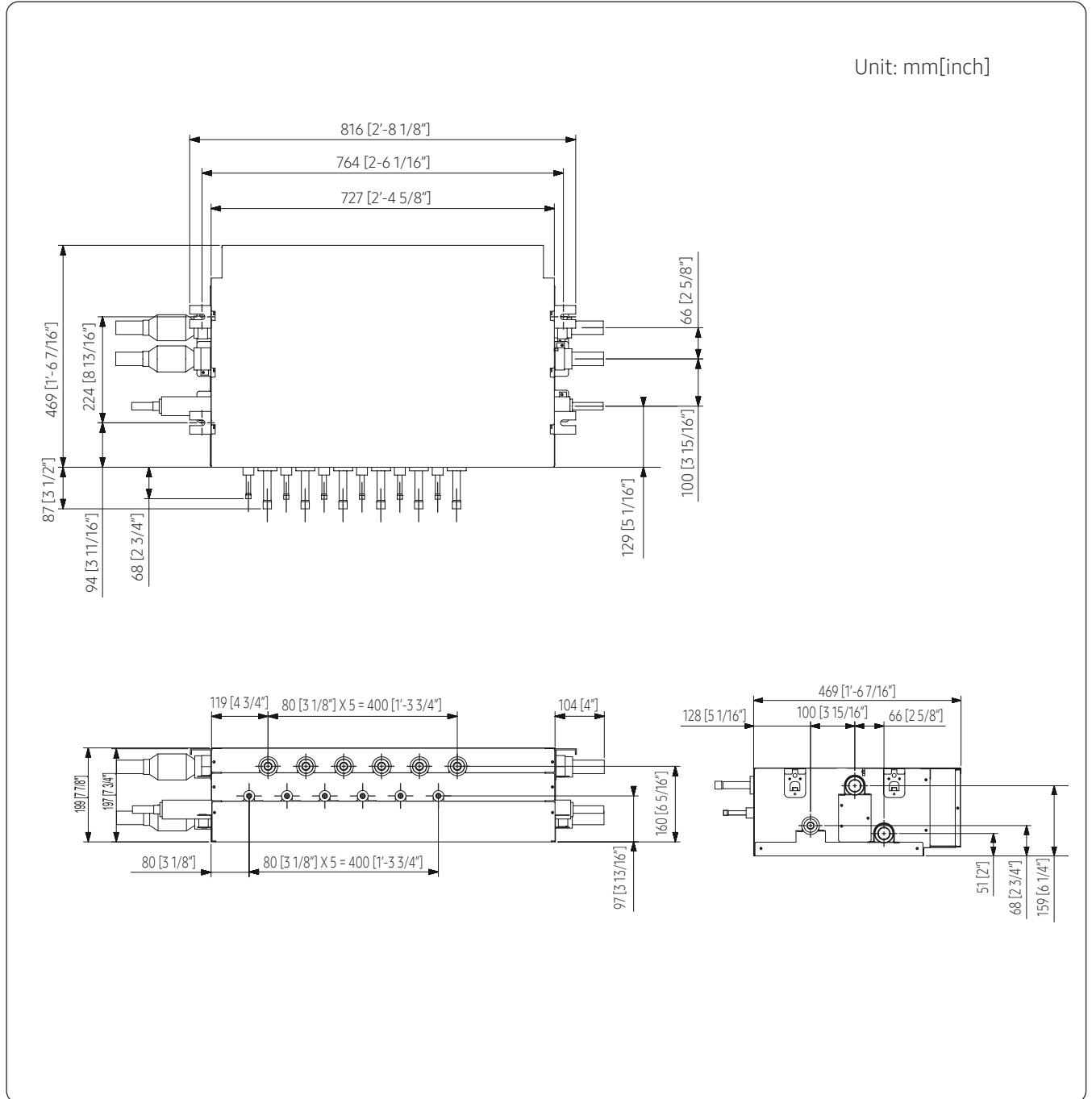

1. MCU (Mode Control Unit)

1.4. Technical drawings- For DVM S Eco Only

MCU-R4NEK0N

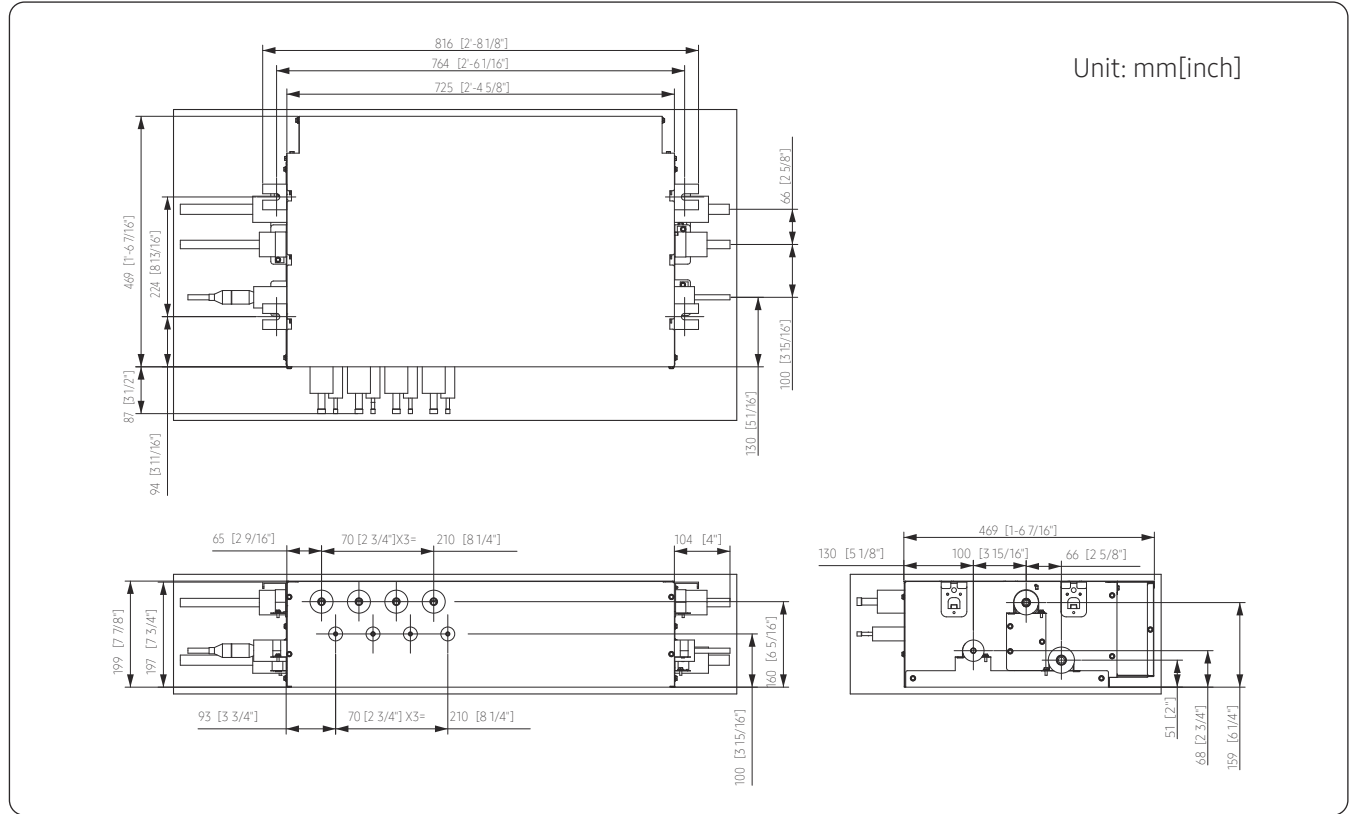

MCU-S6NEK3N

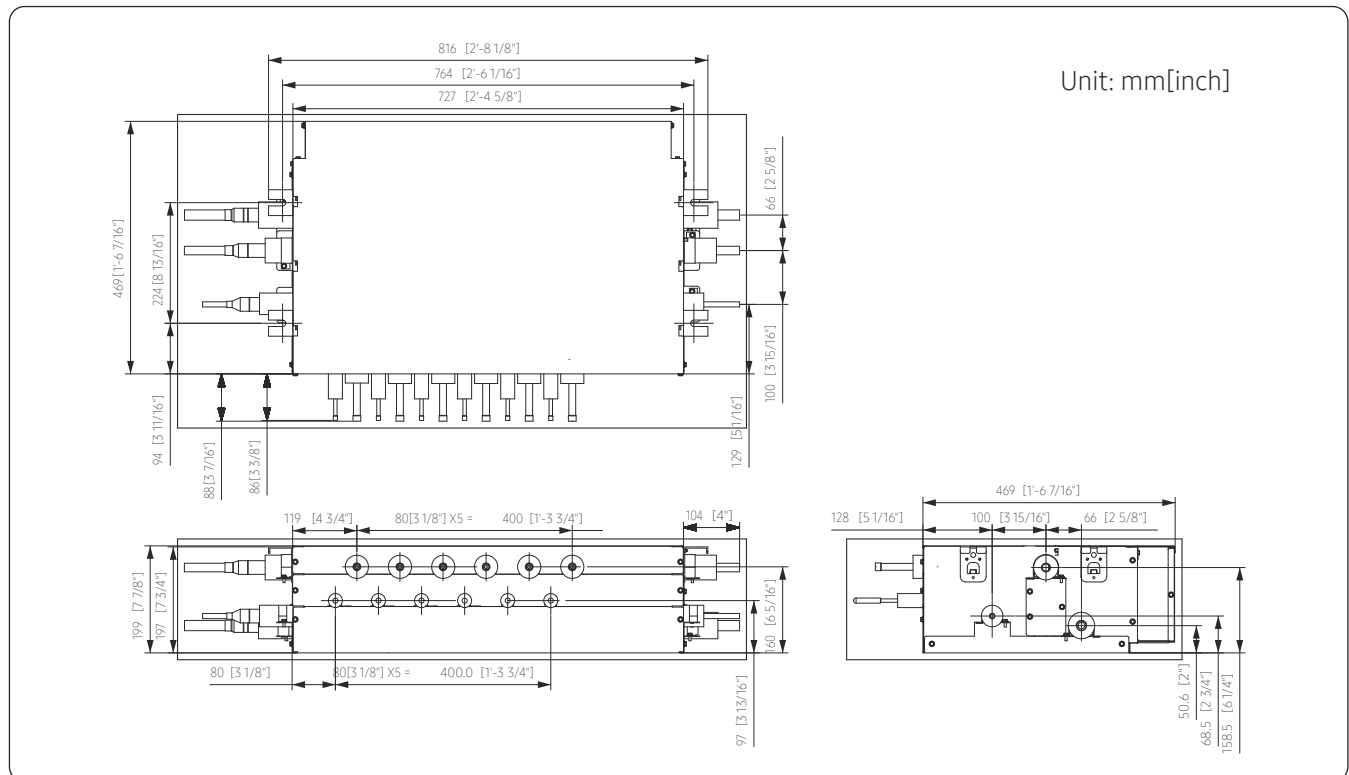

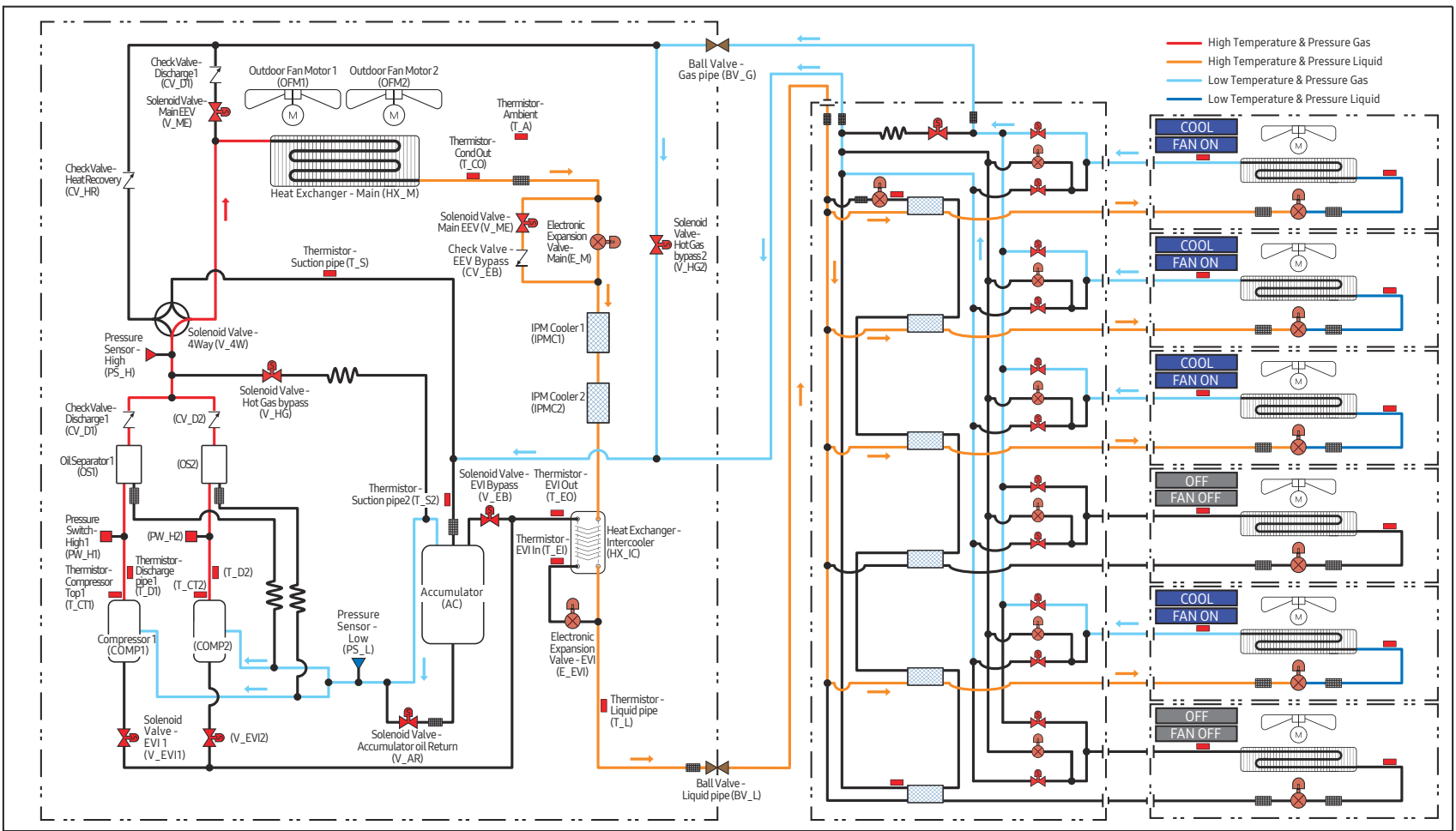

- High Temperature & Pressure Gas
- High Temperature & Pressure Liquid
- Low Temperature & Pressure Gas
- Low Temperature & Pressure Liquid

Piping drawings Cooling mode

1. MCU (Mode Control Unit)

1. MCU (Mode Control Unit)

Piping drawings Heating mode

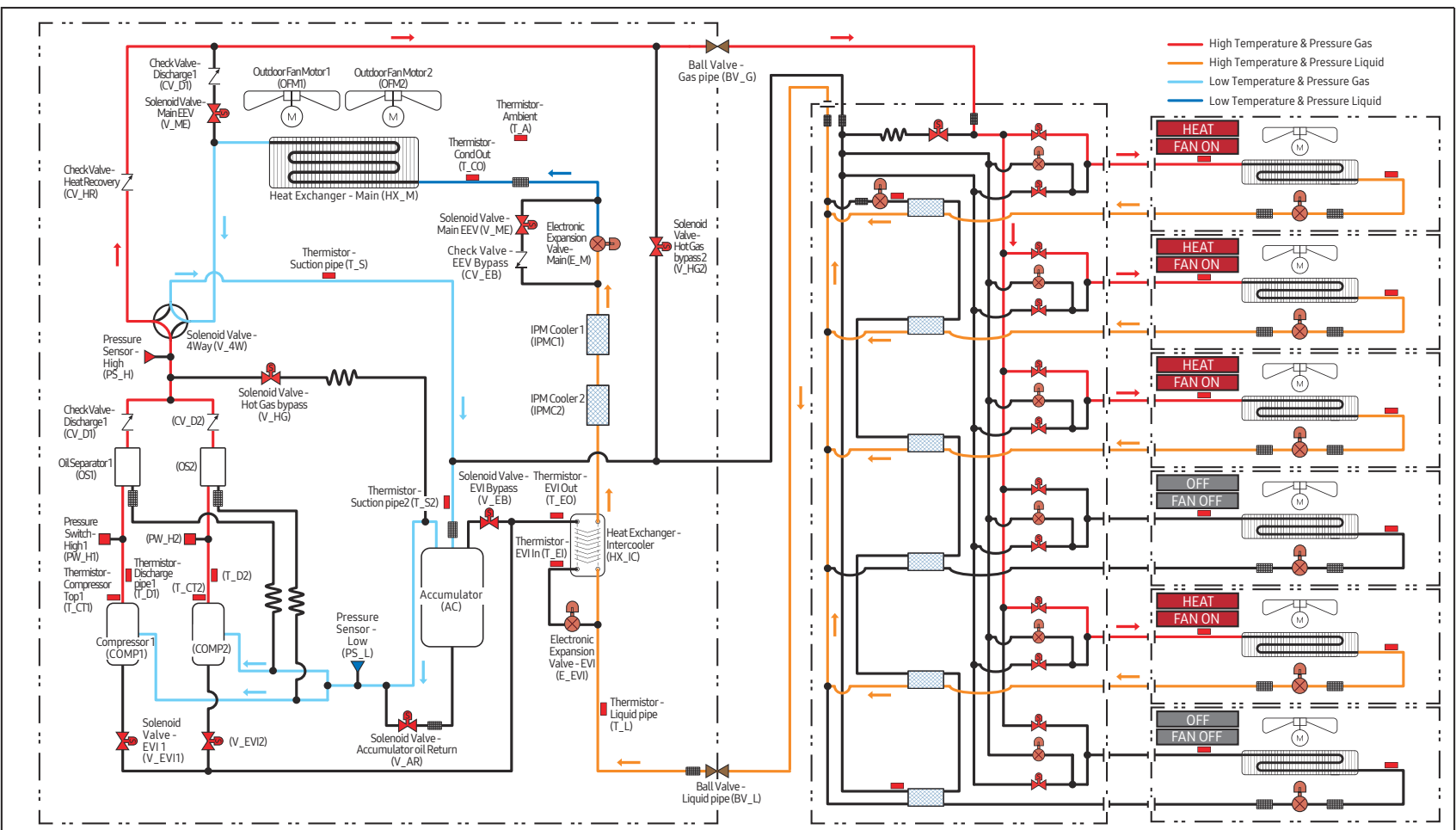

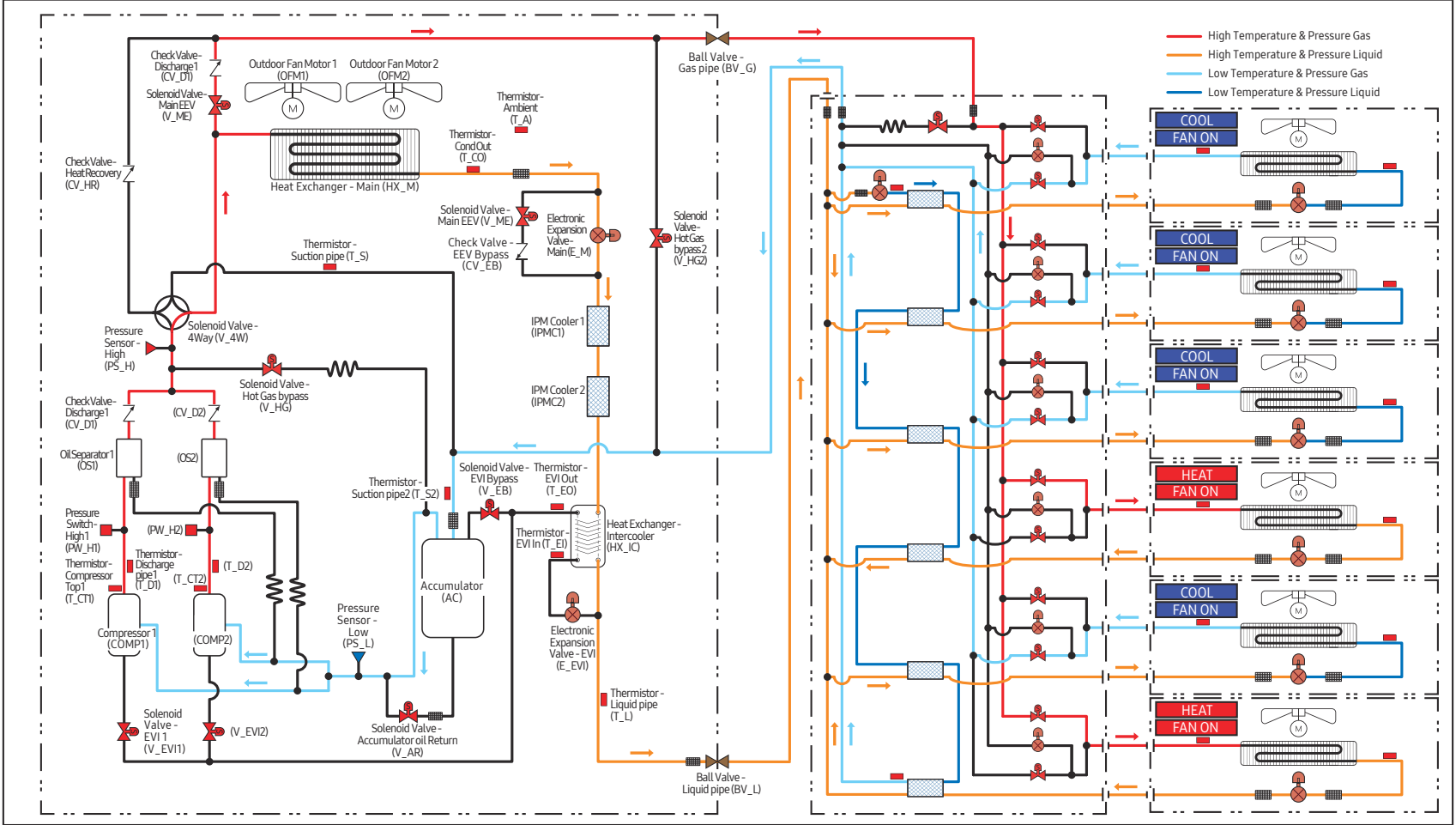

Piping drawings Main Cooling mode

1. MCU (Mode Control Unit)

1. MCU (Mode Control Unit)

Piping drawings Main Heating mode

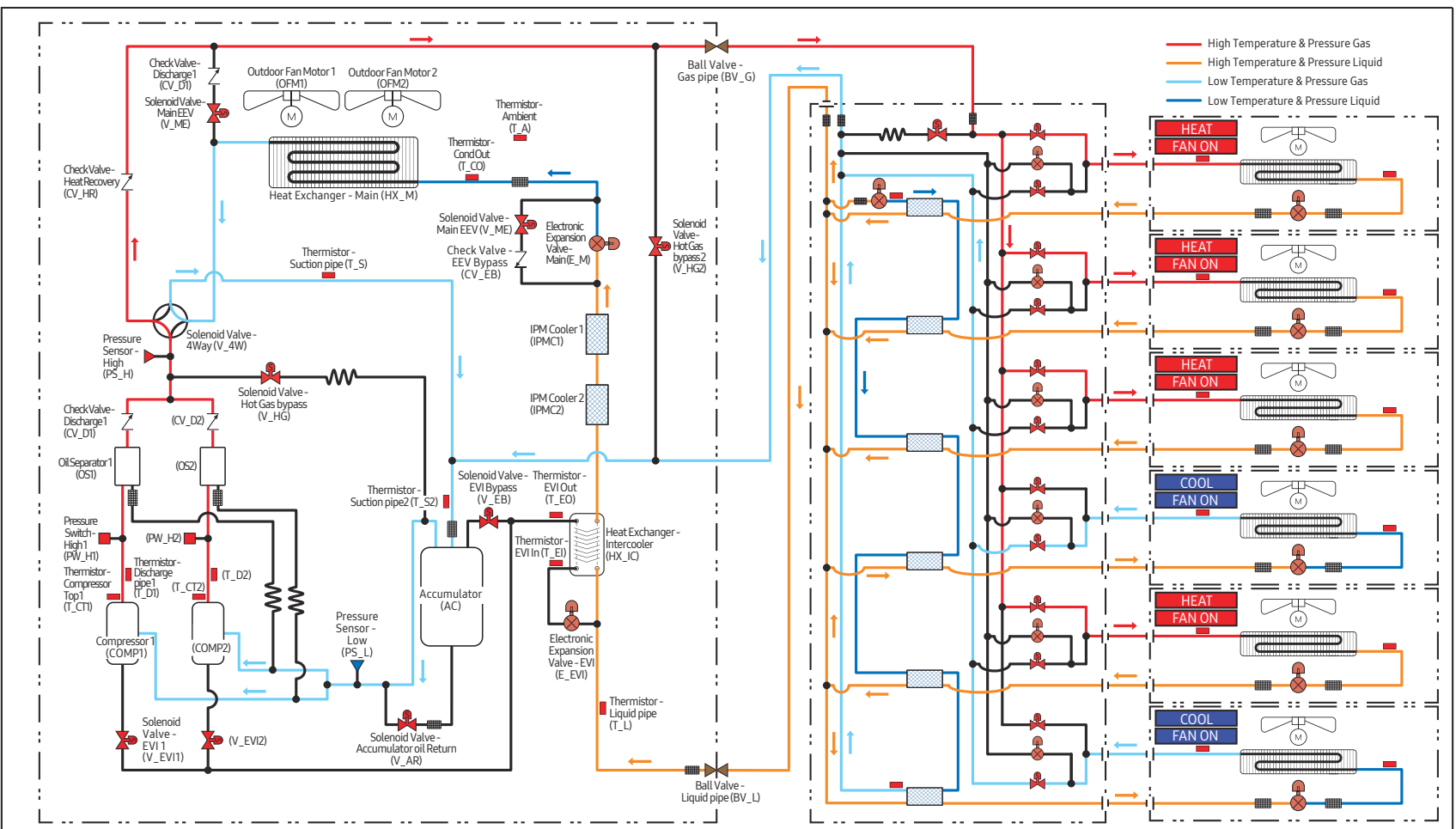

1. MCU (Mode Control Unit)

Piping drawings - For DVM SEco Only

• Cooling mode

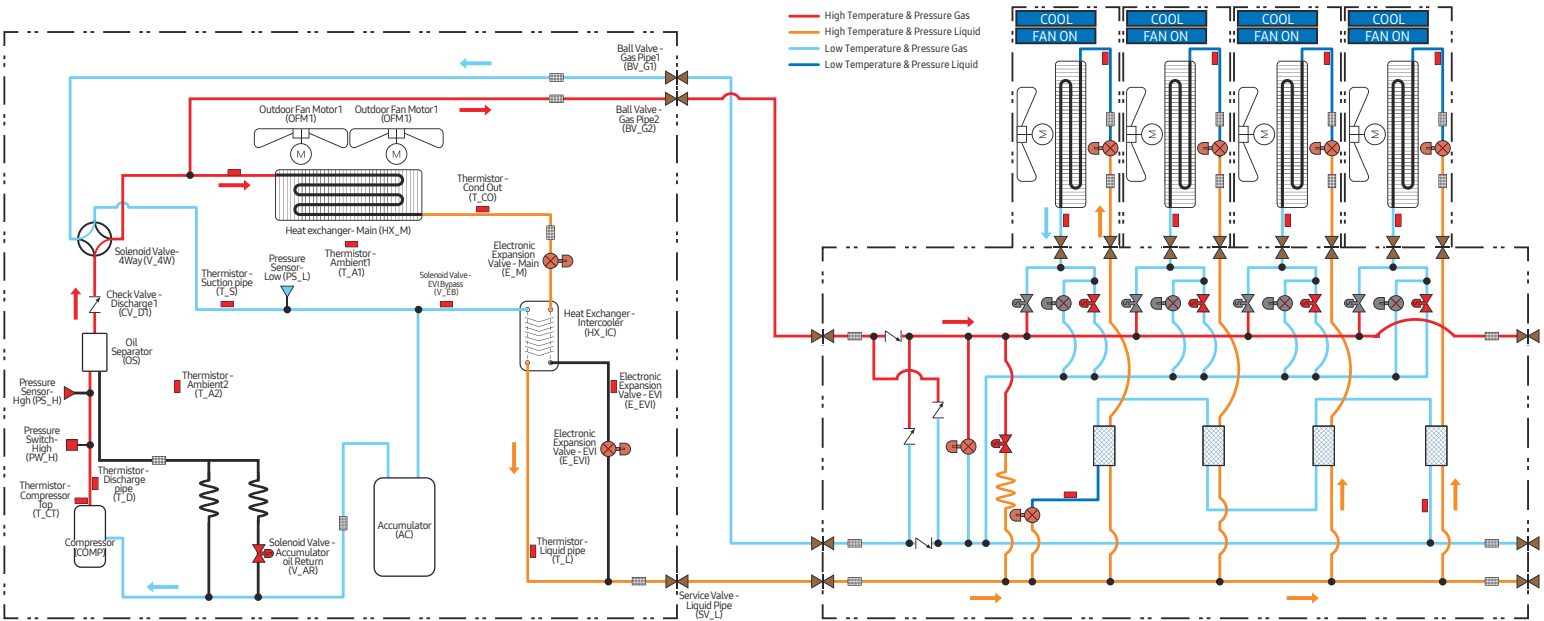

• Heating mode

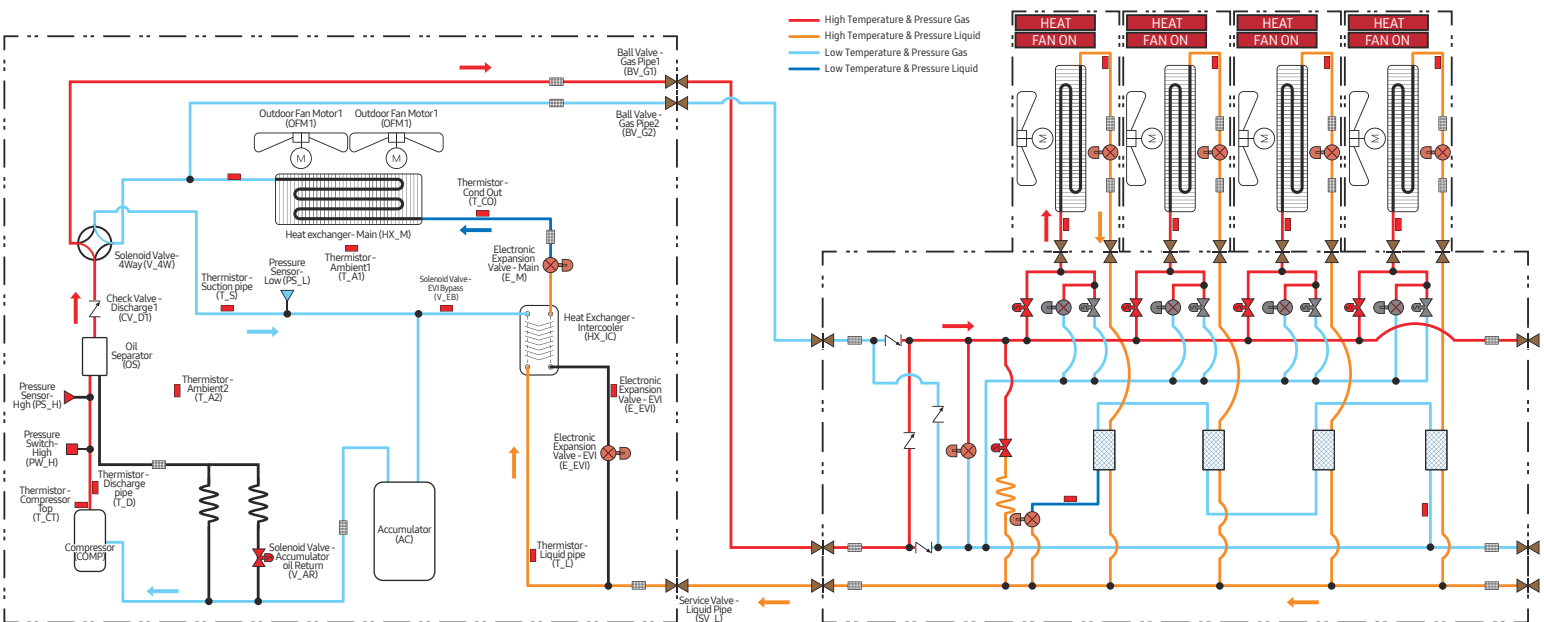

1. MCU (Mode Control Unit)

Piping drawings - For DVM S Eco Only

• Main cooling mode

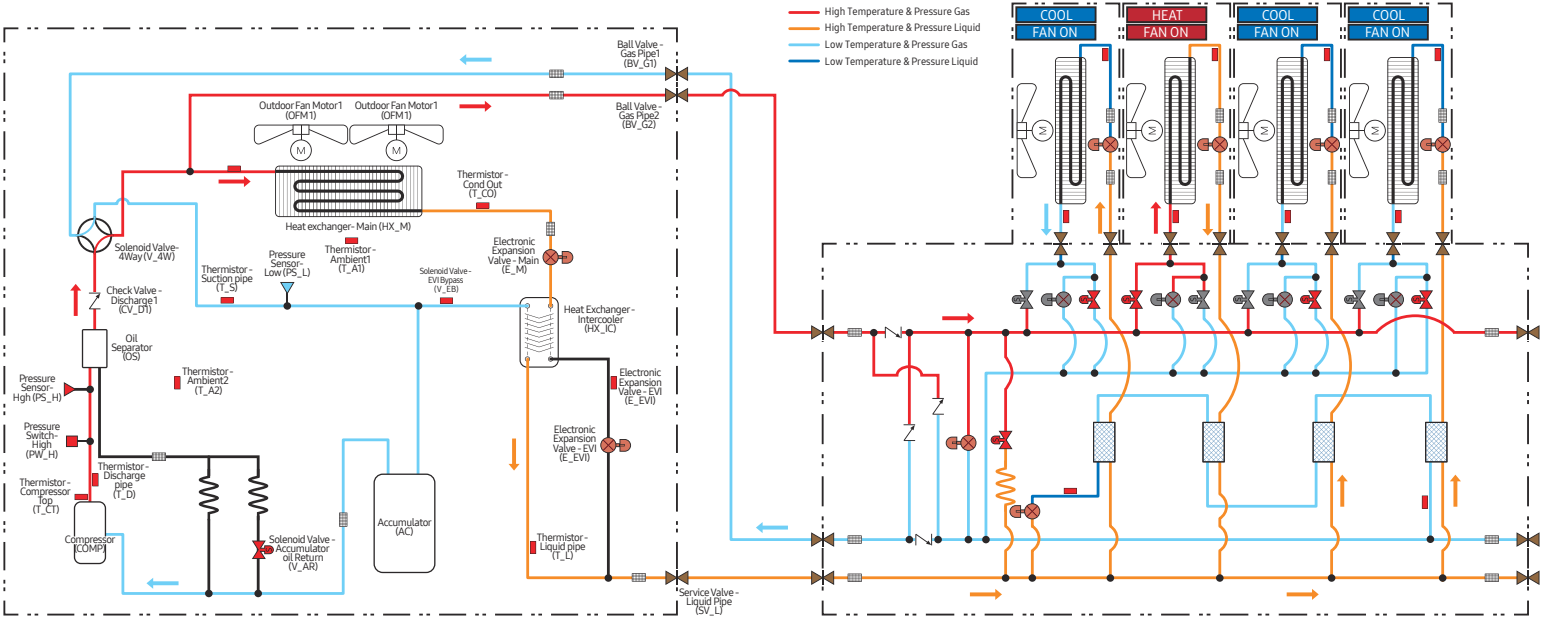

• Main heating mode

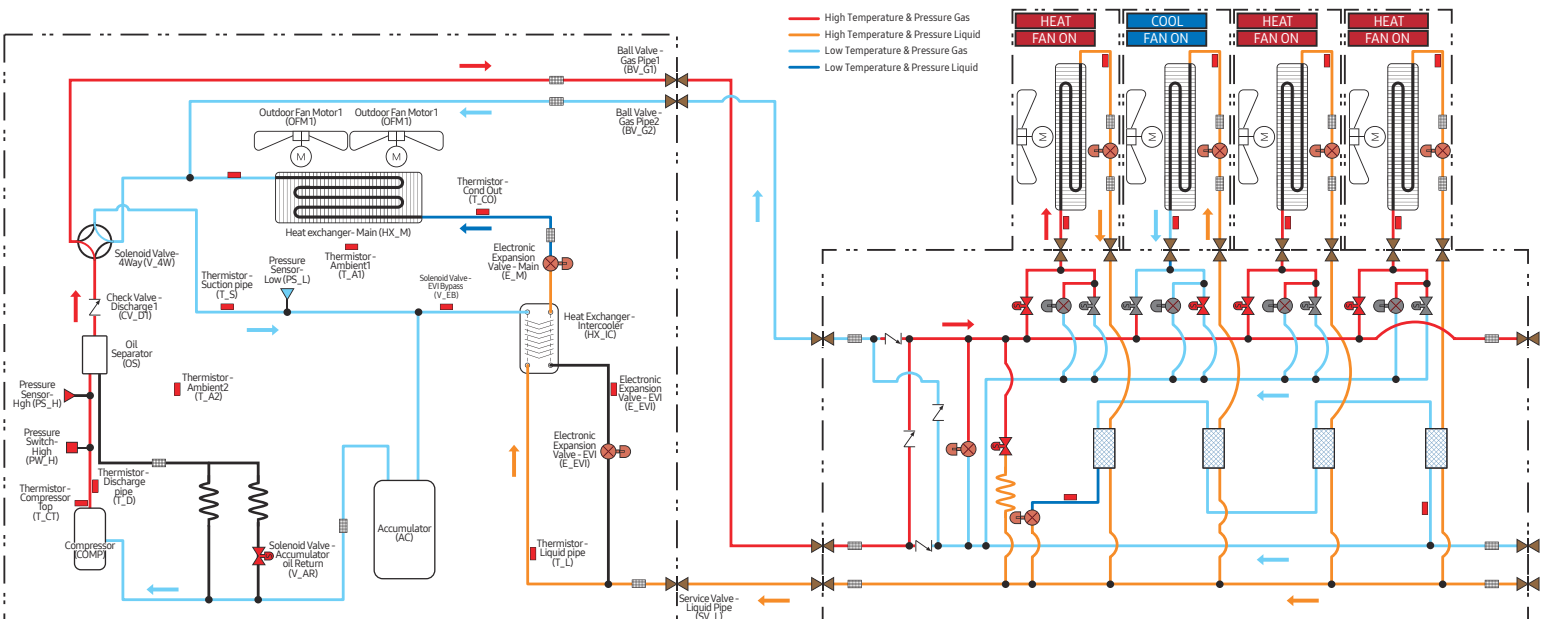

1. MCU (Mode Control Unit)

MCU Kit Wiring drawing

MCU-S6NEE1N, MCU-S4NEE1N, MCU-S4NEE2N, MCU-S2NEK1N, MCU-S6NEK3N

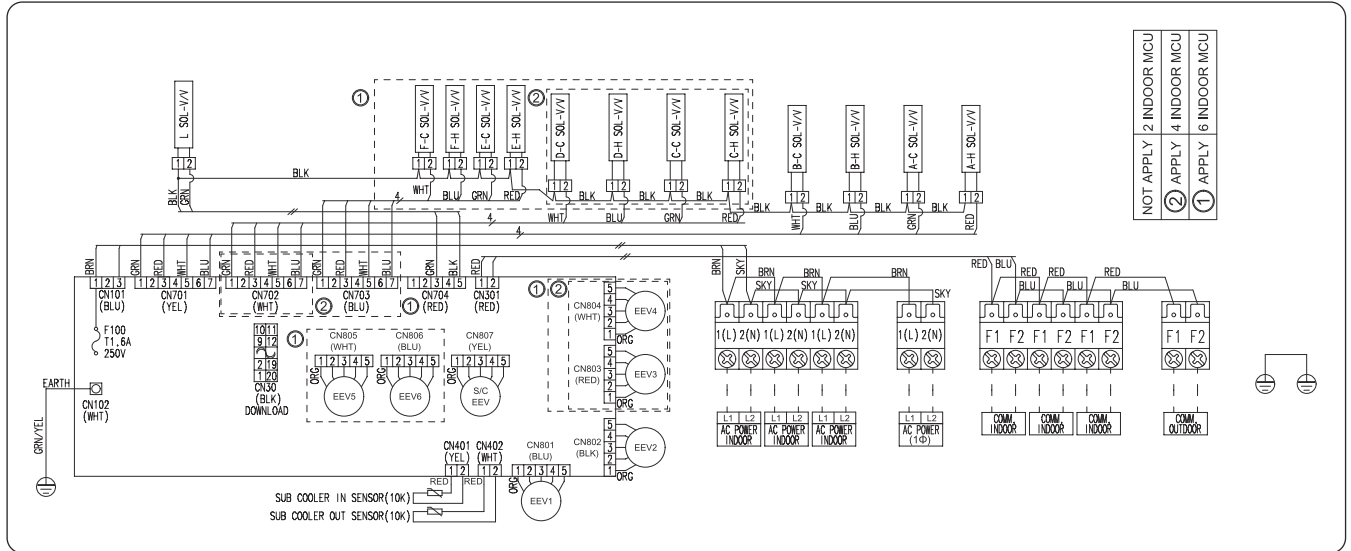

EEV1	electronic expansion valve	EEV2	electronic expansion valve	EEV3	electronic expansion valve
EEV4	electronic expansion valve	EEV5	electronic expansion valve	EEV6	electronic expansion valve
S/C EEV	electronic expansion valve (Sub cooler)	F100	FUSE		

NOTE

- This wiring diagram applies only to the MCU kits.
- Symbols show as follow : BLK: black, RED: red, BLU: blue, WHT: white, YEL: yellow, BRN: brown, SKY: skyblue: GRN: green
- For connection wiring indoor-outdoor transmission F1-F2
- Protective earth(SCREW) , CN *: connector, $\frac{N}{x}$: The quantity

1. MCU (Mode Control Unit)

HR Changer Wiring drawing - For DVM S Eco Only

MCU-R4NEKON

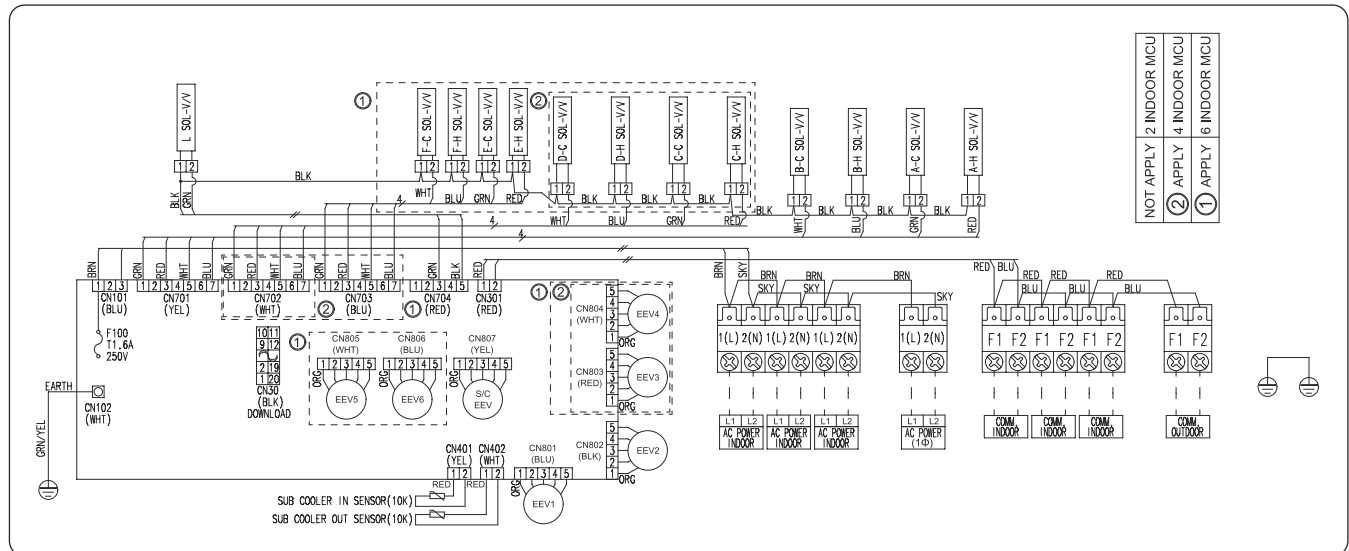

EEV1	electronic expansion valve	EEV2	electronic expansion valve	EEV3	electronic expansion valve
EEV4	electronic expansion valve	S/C EEV	electronic expansion valve (Sub cooler)	F100	FUSE
HR EEV	electronic expansion valve				

NOTE

- This wiring diagram applies only to the HR Changer
- Symbols show as follow : BLK: black, RED: red, BLU: blue, WHT: white, YEL: yellow, BRN: brown, SKY: skyblue: GRN: green
- For connection wiring indoor-outdoor transmission F1-F2
- Protective earth(SCREW) , CN *: connector, $\frac{N}{x}$: The quantity

1. MCU (Mode Control Unit)

Wiring drawings

MCU-S1NEK1N, MCU-S6NEK2N, MCU-S4NEK3N, MCU-S2NEK2N

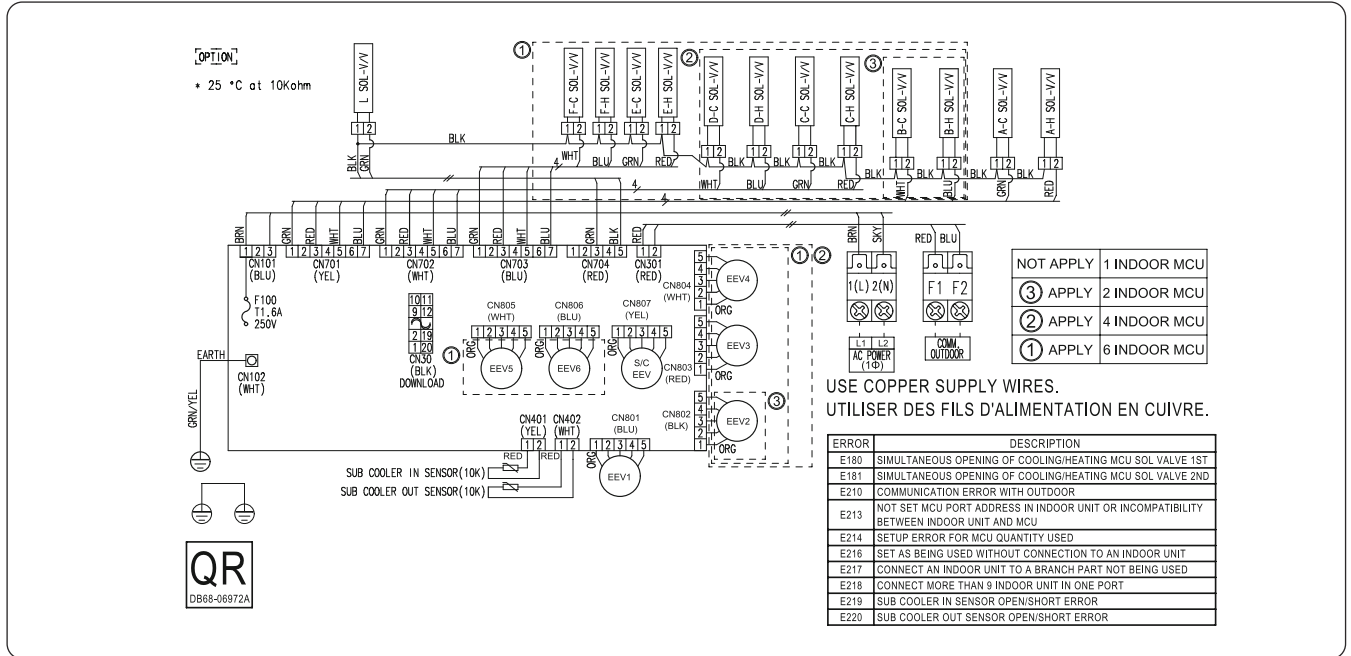

EEV1	electronic expansion valve	EEV2	electronic expansion valve	EEV3	electronic expansion valve
EEV4	electronic expansion valve	EEV5	electronic expansion valve	EEV6	electronic expansion valve
S/C EEV	electronic expansion valve (Sub cooler)	F100	FUSE		

NOTE

- This wiring diagram applies only to the MCU kits.
- Symbols show as follow : BLK: black, RED: red, BLU: blue, WHT: white, YEL: yellow, BRN: brown, SKY: skyblue: GRN: green
- For connection wiring indoor-outdoor transmission F1-F2
- Protective earth(SCREW) , CN *: connector, \overline{N} : The quantity

1. MCU (Mode Control Unit)

1.5. Sound pressure level

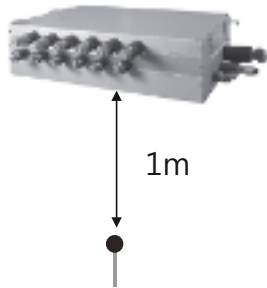

Model	Sound Level (dBA)
MCU-S6NEE1N	34
MCU-S4NEE1N	
MCU-S4NEE2N	
MCU-S2NEK1N	
MCU-R4NEK0N	36
MCU-S6NEK2N	
MCU-S4NEK3N	
MCU-S6NEK3N	34
MCU-S2NEK2N	34
MCU-S1NEK1N	33

- This value was measured at steady state in anechoic chamber and may vary depending on operating condition.
- Sound pressure level will vary depending on a range of factors such as the construction of the particular room where the equipment is installed.

NC curve

MCU-S6NEE1N, MCU-S4NEE1N, MCU-S4NEE2N, MCU-S2NEK1N, MCU-R4NEK0N(HR CHANGER), MCU-S2NEK2N

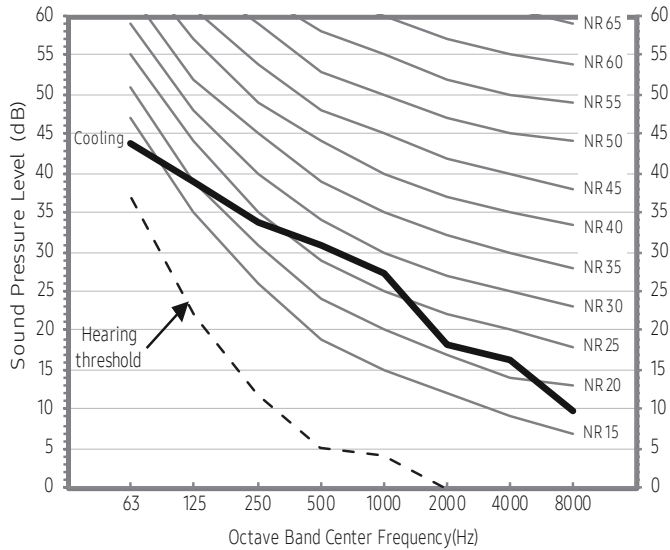

1. MCU (Mode Control Unit)

1.5. Sound pressure level

NC curve

MCU-S6NEK2N, MCU-S4NEK3N, MCU-S6NEK3N

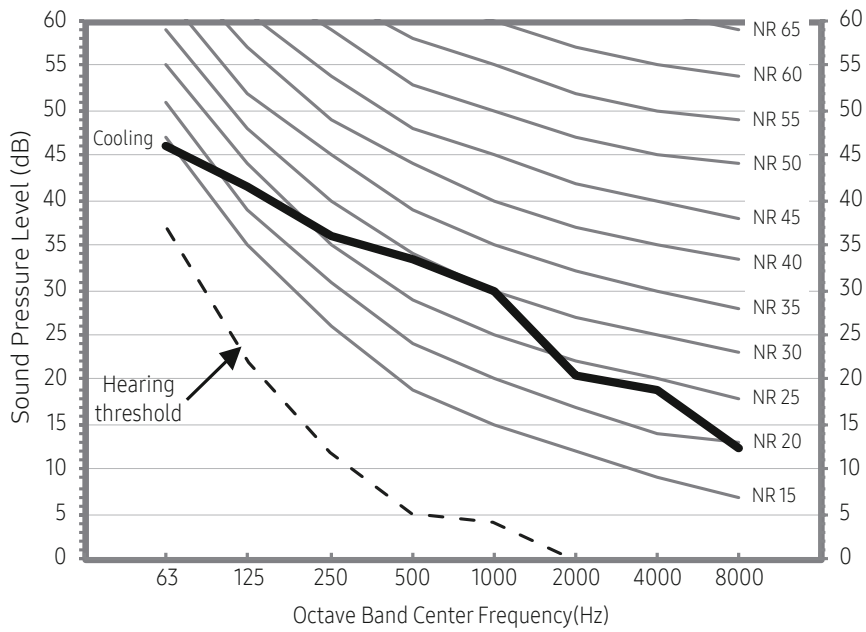

MCU-S1NEK1N

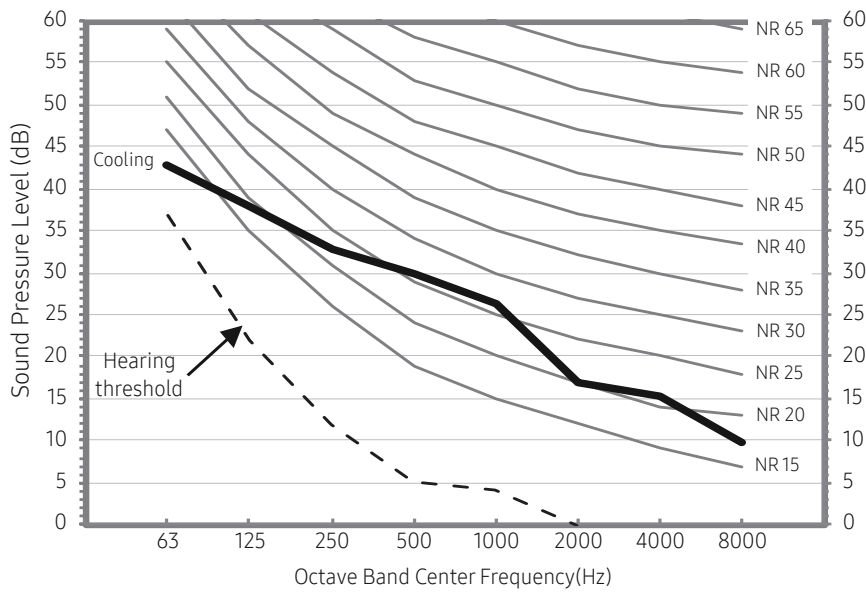

2. EEV (Electronic Expansion Valve) kit

2.1 Feature

EEV kit

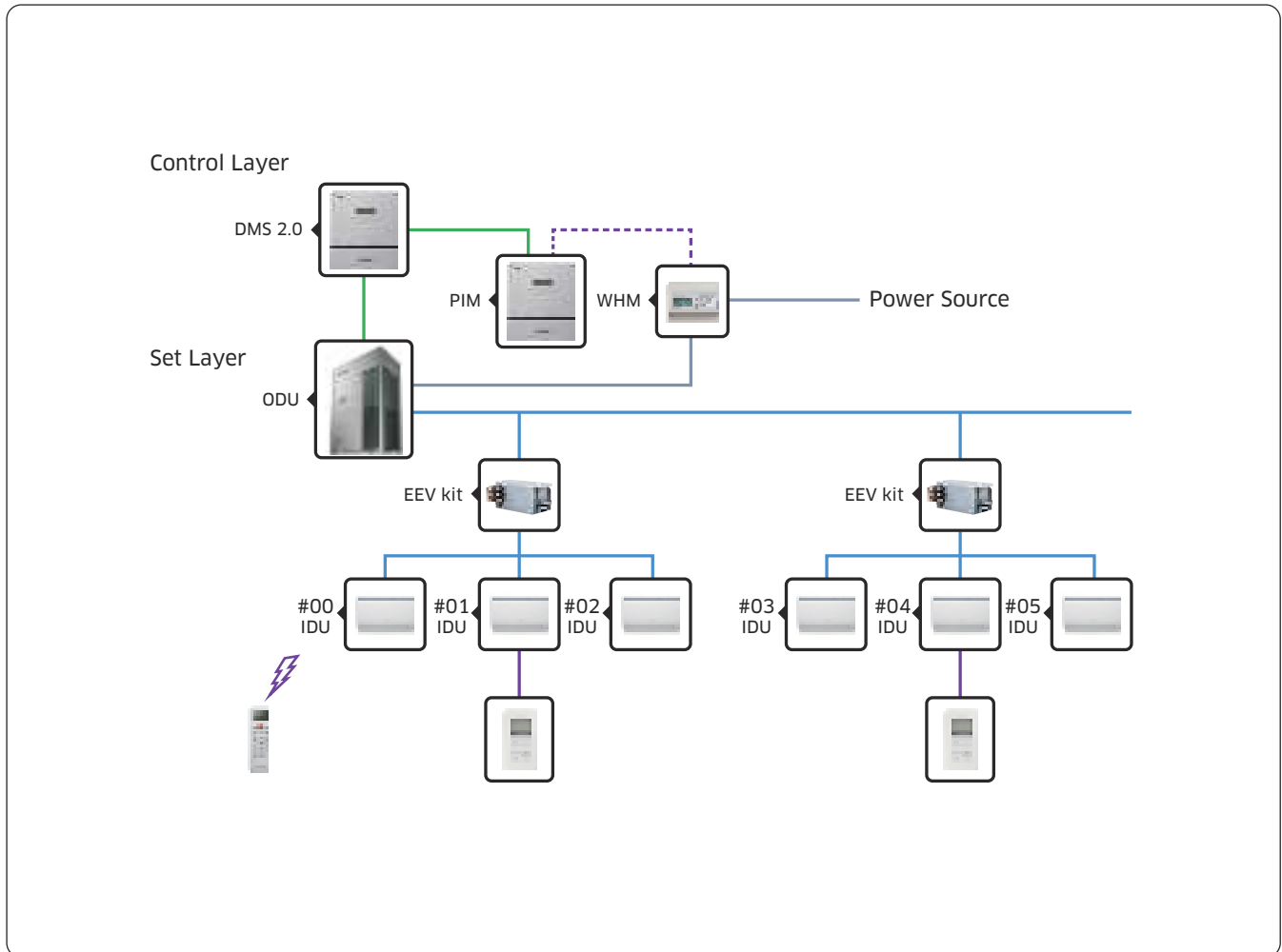

2. EEV (Electronic Expansion Valve) kit

Single EEV kits

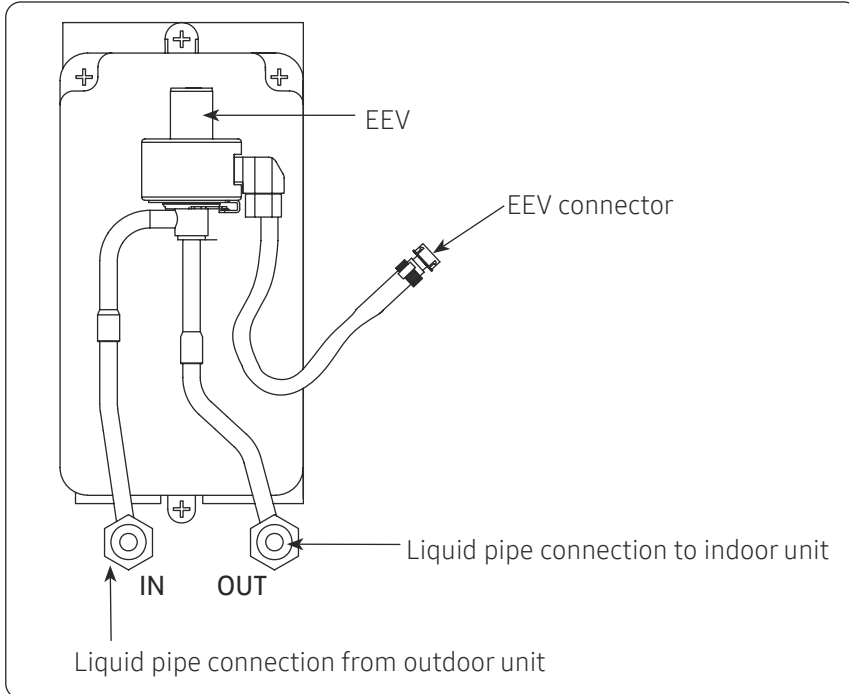

Two rooms EEV kits

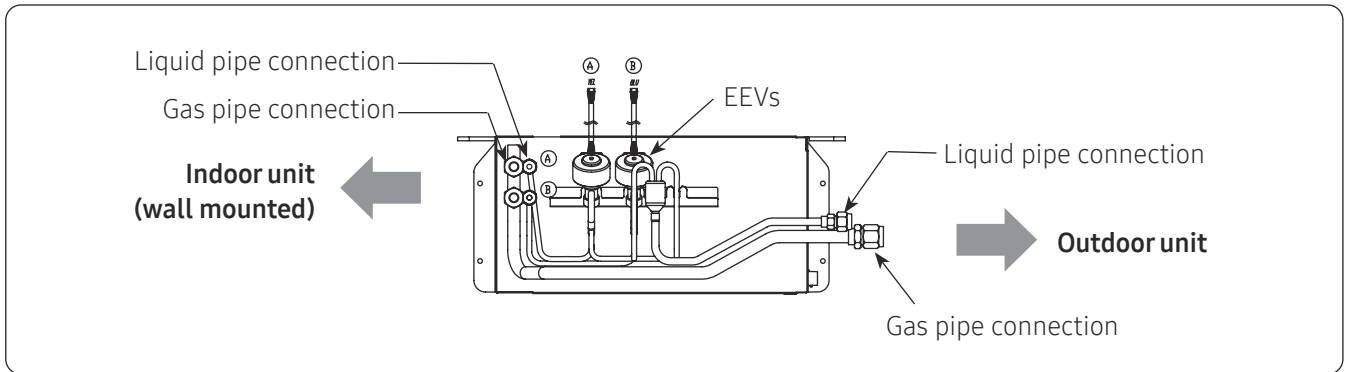

Three rooms EEV kits

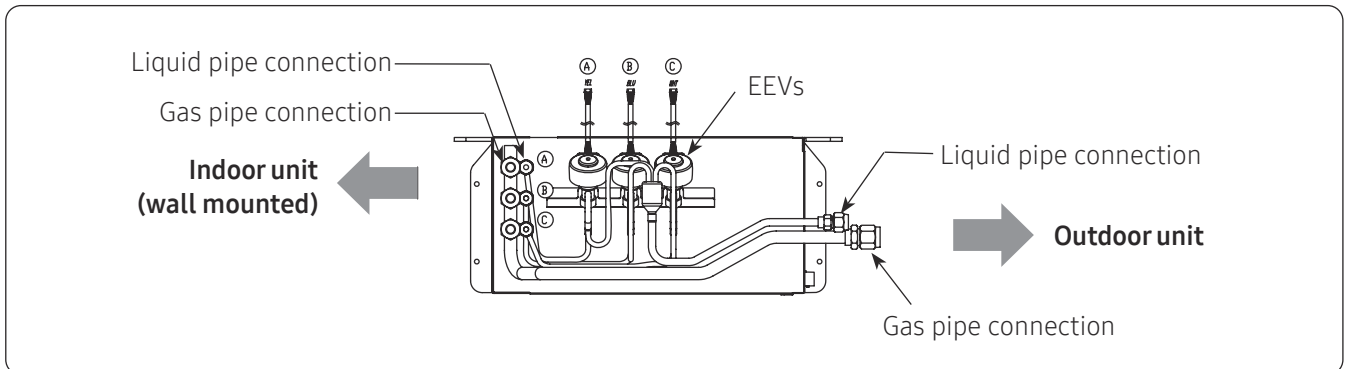

2. EEV (Electronic Expansion Valve) kit

2.2. Line-up

2.2.1 Single EEV kit

Model	Description				
	Connectable capacity of indoor units	Quantity of connectable indoor units	Weight (Net)	Indoor units	Remarks
MEV- E24SA	Up to 3.6kW (12.0MBH)	1	1.1kg (2.2 lbs)	Wall mounted units Ceiling units	Extension wire included
MEV- E32SA	4.5 ~ 9kW (15.5 ~ 31MBH)	1	1.1kg (2.2 lbs)		

2.2.2 2/3 Room EEV kit

Model	Connectable capacity of indoor units			Refrigerant
	A	B	C	
MXD-E24K132*	1.5 ~ 4.5 kW (7000 ~ 15500 Btu/h)	5 ~ 9 kW (17000 ~ 31000 Btu/h)	-	R-410A
MXD-E24K200*	1.5 ~ 4.5 kW (7000 ~ 15500 Btu/h)	1.5 ~ 4.5 kW (7000 ~ 15500 Btu/h)	-	
MXD-E24K232*	1.5 ~ 4.5 kW (7000 ~ 15500 Btu/h)	1.5 ~ 4.5 kW (7000 ~ 15500 Btu/h)	5 ~ 9 kW (17000 ~ 31000 Btu/h)	
MXD-E24K300*	1.5 ~ 4.5 kW (7000 ~ 15500 Btu/h)	1.5 ~ 4.5 kW (7000 ~ 15500 Btu/h)	1.5 ~ 4.5 kW (7000 ~ 15500 Btu/h)	
MXD-E32K200*	5 ~ 9 kW (17000 ~ 31000 Btu/h)	5 ~ 9 kW (17000 ~ 31000 Btu/h)	-	
MXD-E32K224*	5 ~ 9 kW (17000 ~ 31000 Btu/h)	5 ~ 9 kW (17000 ~ 31000 Btu/h)	1.5 ~ 4.5 kW (7000 ~ 15500 Btu/h)	
MXD-E32K300*	5 ~ 9 kW (17000 ~ 31000 Btu/h)	5 ~ 9 kW (17000 ~ 31000 Btu/h)	5 ~ 9 kW (17000 ~ 31000 Btu/h)	

2. EEV (Electronic Expansion Valve) kit

2.3. Spec Sheet

Type			EEV kit					
Model			MEV- E24SA	MEV- E32SA	MXD-E24K132*	MXD-E24K200*	MXD-E24K232*	
Maximum number of connectable indoor units		EA	1	1	2	2	3	
Power Supply		Ø, #, V, Hz	DC12V	DC12V	220-240V~ 50Hz	220-240V~ 50Hz	220-240V~ 50Hz	
					208-230V~ 60Hz	208-230V~ 60Hz	208-230V~ 60Hz	
Piping Connections	Inlet Pipe	Liquid Pipe	Ø, mm	6.35	6.35	9.52	9.52	9.52
			Ø, inch	¼"	¼"	3/8"	3/8"	3/8"
		Gas Pipe	Ø, mm	-	-	15.88	15.88	15.88
			Ø, inch	-	-	5/8"	5/8"	5/8"
	Outlet Pipe 1	Liquid Pipe	Ø, mm	6.35	6.35	6.35	6.35	6.35
			Ø, inch	¼"	¼"	¼"	¼"	¼"
		Gas Pipe	Ø, mm	-	-	12.7	12.7	12.7
			Ø, inch	-	-	½"	½"	½"
	Outlet Pipe 2	Liquid Pipe	Ø, mm	-	-	9.52	6.35	6.35
			Ø, inch	-	-	3/8"	¼"	¼"
		Gas Pipe	Ø, mm	-	-	15.88	12.7	12.7
			Ø, inch	-	-	5/8"	½"	½"
	Outlet Pipe 3	Liquid Pipe	Ø, mm	-	-	-	-	9.52
			Ø, inch	-	-	-	-	3/8"
		Gas Pipe	Ø, mm	-	-	-	-	15.88
			Ø, inch	-	-	-	-	5/8"
External Dimension	Net Weight		kg (lbs)	1.1 (2.4)	1.1 (2.4)	7 (15.4)	7 (15.4)	7.6 (16.8)
	Shipping Weight		kg (lbs)	1.4 (3.1)	1.6 (3.5)	8.8 (19.4)	8.8 (19.4)	9.4 (20.7)
	Net Dimensions (WxHxD)		mm (inch)	86X201X118 (3 3/8x7 15/16x4 5/8)	86X201X118 (3 3/8x7 15/16x4 5/8)	450X333X204 (17 3/4 x 13 1/8 x 8)	450X333X204 (17 3/4 x 13 1/8 x 8)	500X333X204 (17 3/4 x 13 1/8 x 8)
	Shipping Dimensions (WxHxD)		mm (inch)	226X306X134 (8 7/8 x 12 x 5 1/4)	226X306X134 (8 7/8 x 12 x 5 1/4)	596X382X276 (23 1/2 x 15 x 10 7/8)	596X382X276 (23 1/2 x 15 x 10 7/8)	596X382X276 (23 1/2 x 15 x 10 7/8)
Installation	Indoor unit's Capacity	1 port	kW	Up to 3.6	4.5 ~ 9.0	1.5 ~ 4.5	1.5 ~ 4.5	1.5 ~ 4.5
		2 port	kW	-	-	5 ~ 9	1.5 ~ 4.5	1.5 ~ 4.5
		3 port	kW	-	-	-	-	5 ~ 9

2. EEV (Electronic Expansion Valve) kit

2.3. Spec Sheet

Type			EEV kit				
Model			MXD-E24K300*	MXD-E32K200*	MXD-E32K224*	MXD-E32K300*	
Maximum number of connectable indoor units		EA	3	2	3	3	
Power Supply		Ø, #, V, Hz	220-240V~ 50Hz	220-240V~ 50Hz	220-240V~ 50Hz	220-240V~ 50Hz	
			208-230V~ 60Hz	208-230V~ 60Hz	208-230V~ 60Hz	208-230V~ 60Hz	
Piping Connections	Inlet Pipe	Liquid Pipe	Ø, mm	9.52	9.52	9.52	9.52
			Ø, inch	3/8"	3/8"	3/8"	3/8"
		Gas Pipe	Ø, mm	15.88	15.88	15.88	15.88
			Ø, inch	5/8"	5/8"	5/8"	5/8"
	Outlet Pipe 1	Liquid Pipe	Ø, mm	6.35	9.52	9.52	9.52
			Ø, inch	1/4"	3/8"	3/8"	3/8"
		Gas Pipe	Ø, mm	12.7	15.88	15.88	15.88
			Ø, inch	1/2"	5/8"	5/8"	5/8"
	Outlet Pipe 2	Liquid Pipe	Ø, mm	6.35	9.52	9.52	9.52
			Ø, inch	1/4"	3/8"	3/8"	3/8"
		Gas Pipe	Ø, mm	12.7	15.88	15.88	15.88
			Ø, inch	1/2"	5/8"	5/8"	5/8"
	Outlet Pipe 3	Liquid Pipe	Ø, mm	6.35	-	6.35	9.52
			Ø, inch	1/4"	-	1/4"	3/8"
		Gas Pipe	Ø, mm	12.7	-	12.7	15.88
			Ø, inch	1/2"	-	1/2"	5/8"
External Dimension	Net Weight		kg (lbs)	7.6 (16.8)	7 (15.4)	7.6 (16.8)	7.6 (16.8)
	Shipping Weight		kg (lbs)	9.4 (20.7)	8.8 (19.4)	9.4 (20.7)	9.6 (20.7)
	Net Dimensions (WxHxD)		mm (inch)	500X333X204 (19 11/16 x 13 1/8 x 8 1/16)	450X333X204 (17 11/16 x 13 1/8 x 8 1/16)	500X333X204 (19 11/16 x 13 1/8 x 8 1/16)	500X333X204 (19 11/16 x 13 1/8 x 8 1/16)
	Shipping Dimensions (WxHxD)		mm (inch)	596X382X276 (23 7/16 x 15 3/8 x 10 7/8)	596X382X276 (23 7/16 x 15 3/8 x 10 7/8)	596X382X276 (23 7/16 x 15 3/8 x 10 7/8)	596X382X276 (23 7/16 x 15 3/8 x 10 7/8)
Installation	Indoor unit's Capacity	1 port	kW	1.5 ~ 4.5	5 ~ 9	5 ~ 9	5 ~ 9
		2 port	kW	1.5 ~ 4.5	5 ~ 9	5 ~ 9	5 ~ 9
		3 port	kW	1.5 ~ 4.5	-	1.5 ~ 4.5	5 ~ 9

2. EEV (Electronic Expansion Valve) kit

2.4. Dimensional drawings

Dimensional drawings

Single EEV kit

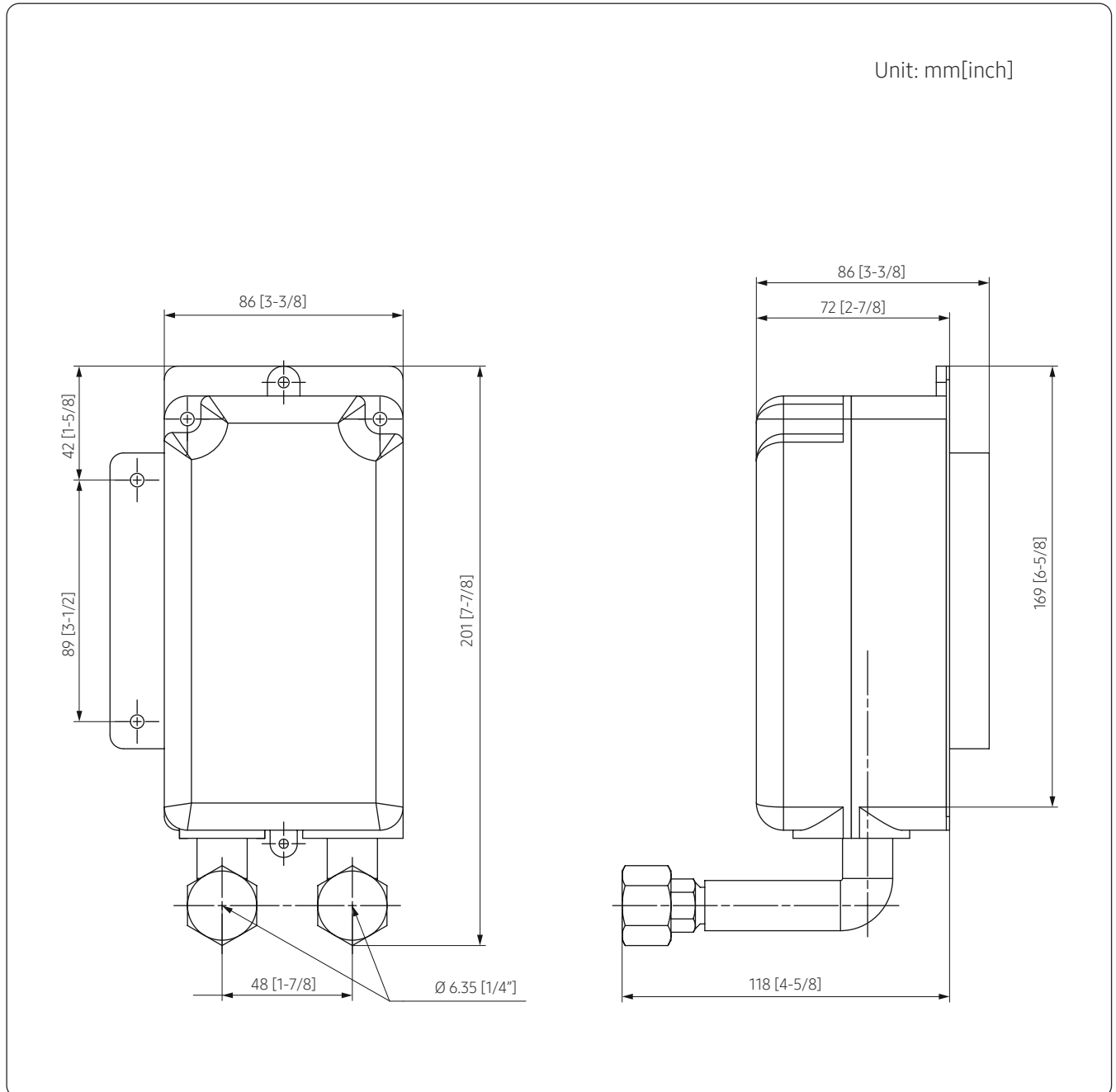

2. EEV (Electronic Expansion Valve) kit

2.4. Dimensional drawings

Two rooms EEV kits

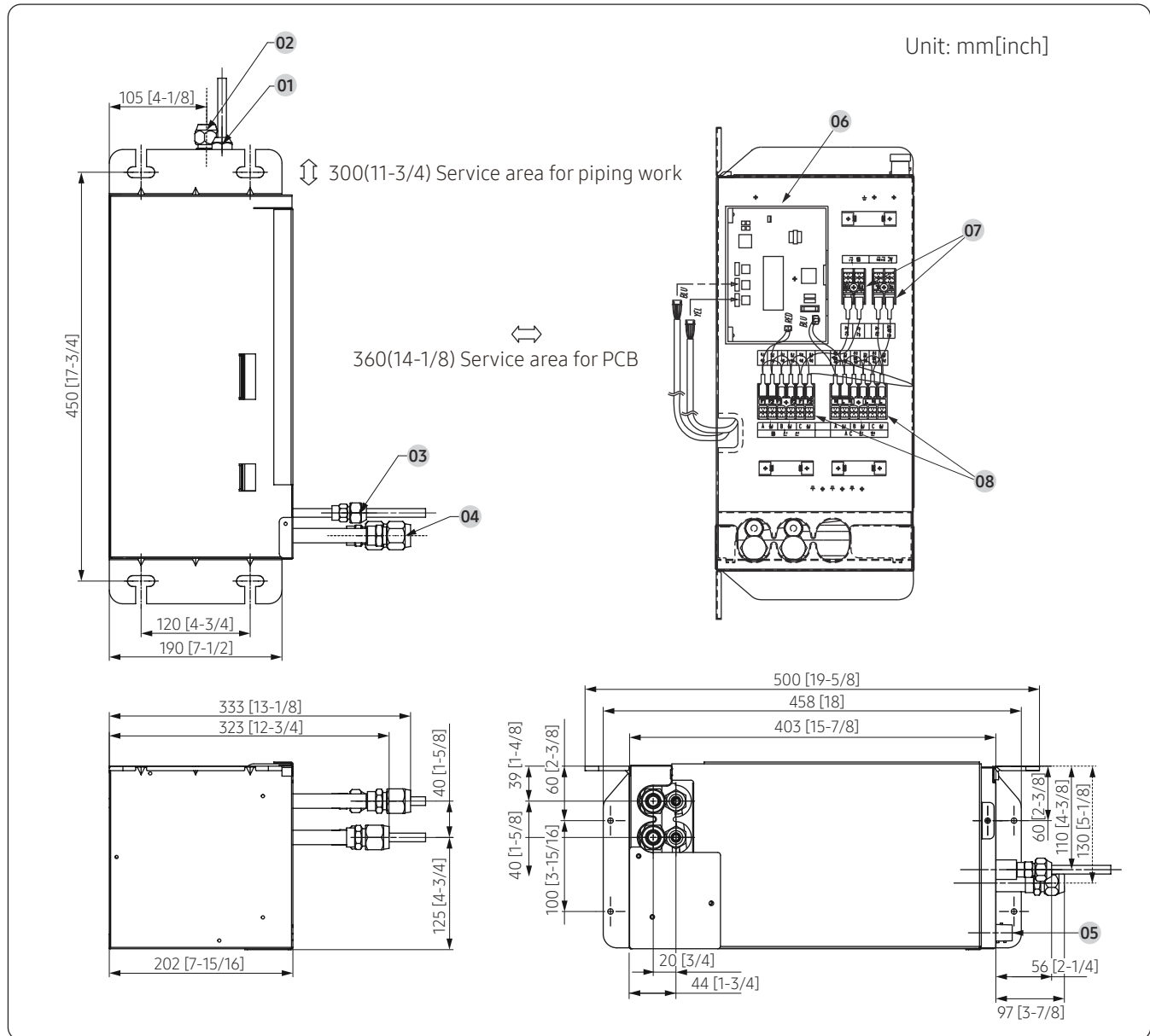

No.	Item
01	Liquid pipe connection from branch joint
02	Gas pipe connection from branch joint
03	Liquid pipe connections to wall mounted/ceiling units
04	Gas pipe connections to wall mounted/ceiling units
05	Condensate drain pipe connection [ID 12.5/OD17.5(ID 1/2" /OD 11/16")]
06	PCB in EEV kits
07	Power and communication wiring terminal blocks from outdoor unit
08	Power and communication wiring terminal blocks to indoor units

		Pipe size [Ø, mm(inch)]		
No.	Model	MXD-E24K132A	MXD-E24K200A	MXD-E32K200A
	01		9.52(3/8)	9.52(3/8)
02		15.88(5/8)	15.88(5/8)	15.88(5/8)
03		6.35(1/4)	6.35(1/4)	9.52(3/8)
		9.52(3/8)	6.35(1/4)	9.52(3/8)
04		12.70(1/2)	12.70(1/2)	15.88(5/8)
		15.88(5/8)	12.70(1/2)	15.88(5/8)

2. EEV (Electronic Expansion Valve) kit

2.4. Dimensional drawings

Three rooms EEV kits

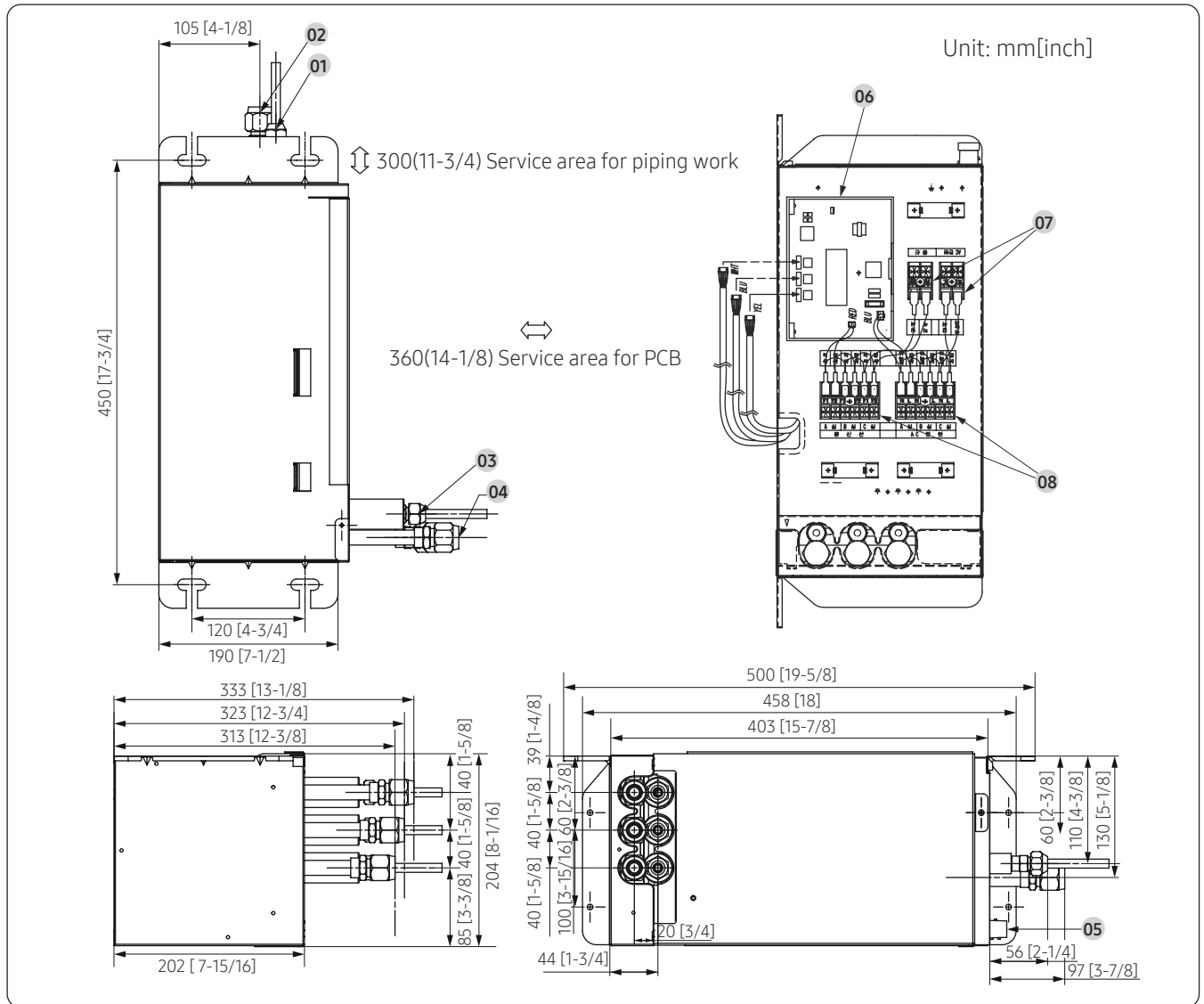

No.	Item
01	Liquid pipe connection from branch joint
02	Gas pipe connection from branch joint
03	Liquid pipe connections to wall mounted/ceiling units
04	Gas pipe connections to wall mounted/ceiling units
05	Condensate drain pipe connection [ID 12.5/OD17.5(ID 1/2" /OD 11/16")]
06	PCB in EEV kits
07	Power and communication wiring terminal blocks from outdoor unit
08	Power and communication wiring terminal blocks to indoor units

		Pipe size [Ø, mm(inch)]			
No.	Model	MXD-E24K232A	MXD-E24K300A	MXD-E32K224A	MXD-E32K300A
	01		9.52(3/8)	9.52(3/8)	9.52(3/8)
02		15.88(5/8)	15.88(5/8)	15.88(5/8)	15.88(5/8)
03		6.35(1/4)	6.35(1/4)	9.52(3/8)	9.52(3/8)
		6.35(1/4)	6.35(1/4)	9.52(3/8)	9.52(3/8)
		9.52(3/8)	6.35(1/4)	6.35(1/4)	9.52(3/8)
04		12.70(1/2)	12.70(1/2)	15.88(5/8)	15.88(5/8)
		12.70(1/2)	12.70(1/2)	15.88(5/8)	15.88(5/8)
		15.88(5/8)	12.70(1/2)	12.70(1/2)	15.88(5/8)

2. EEV (Electronic Expansion Valve) kit

2.4. Dimensional drawings

Wiring drawings

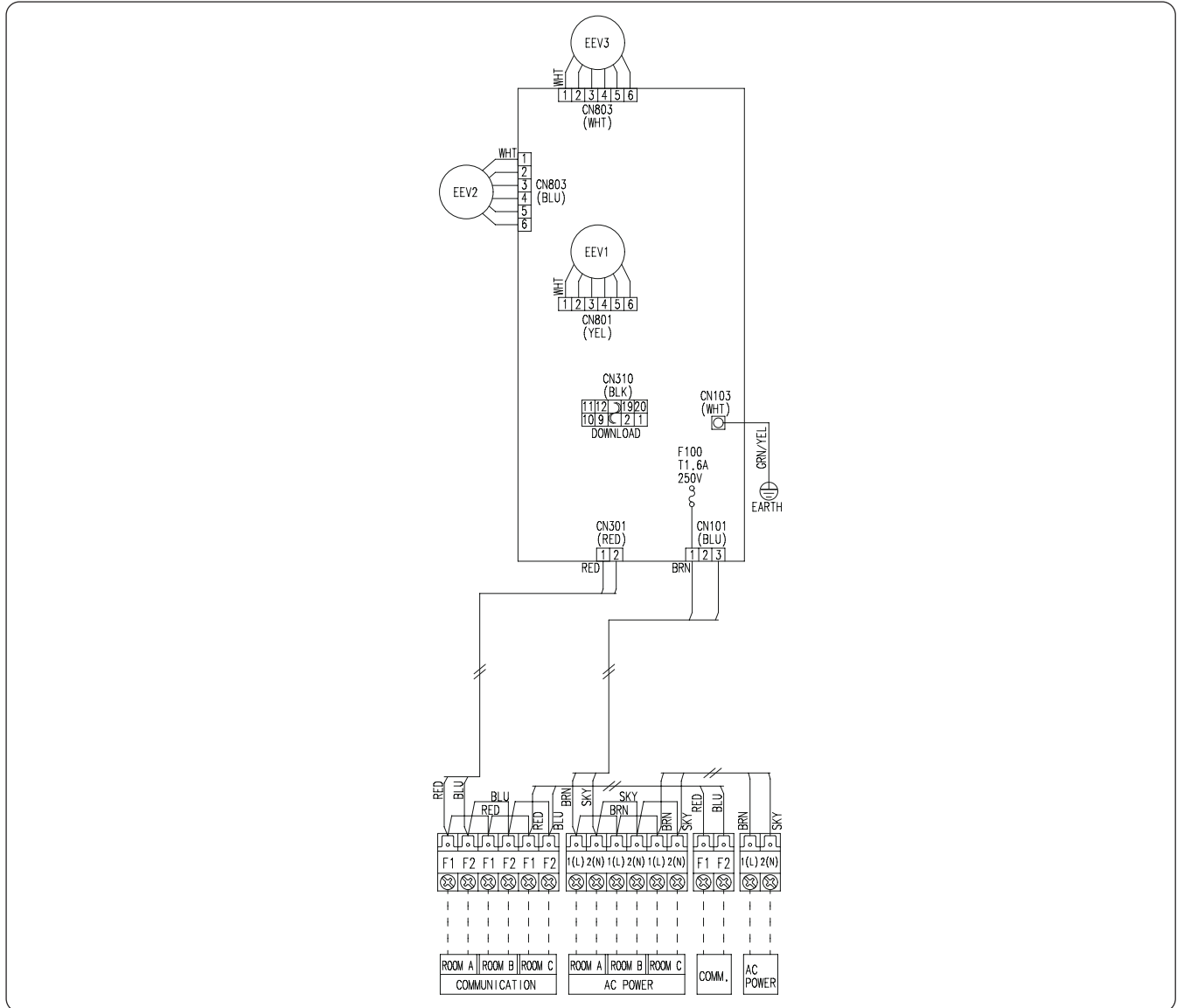

EEV1	electronic expansion valve	EEV2	electronic expansion valve	EEV3	electronic expansion valve
------	----------------------------	------	----------------------------	------	----------------------------

NOTE

- This wiring diagram applies only to the Three rooms EEV kits.
- Symbols show as follow : BLK: black, RED: red, BLU: blue, WHT: white, YEL: yellow, BRN: brown, SKY: skyblue: GRN: green
- For connection wiring indoor-outdoor transmission F1-F2
- Protective earth(SCREW) , CN *: connector, $\frac{N}{x}$: The quantity

3. AHU (Air Handling Unit) kit

3.1 Feature (For VRF outdoor unit)

Optimize performance and energy savings with seamless AHU connectivity

Samsung AHU kit allows DVM S outdoor units to connect to air handling units (AHUs), which results in energy savings and improved performance and efficiency.

Features includes:

- IP54 waterproof certification
- Variable capacity
- 2.5 HP - 40 HP
- Simple BMS application(0~10V, MXD-K/X Series)
- Discharge air temperature control

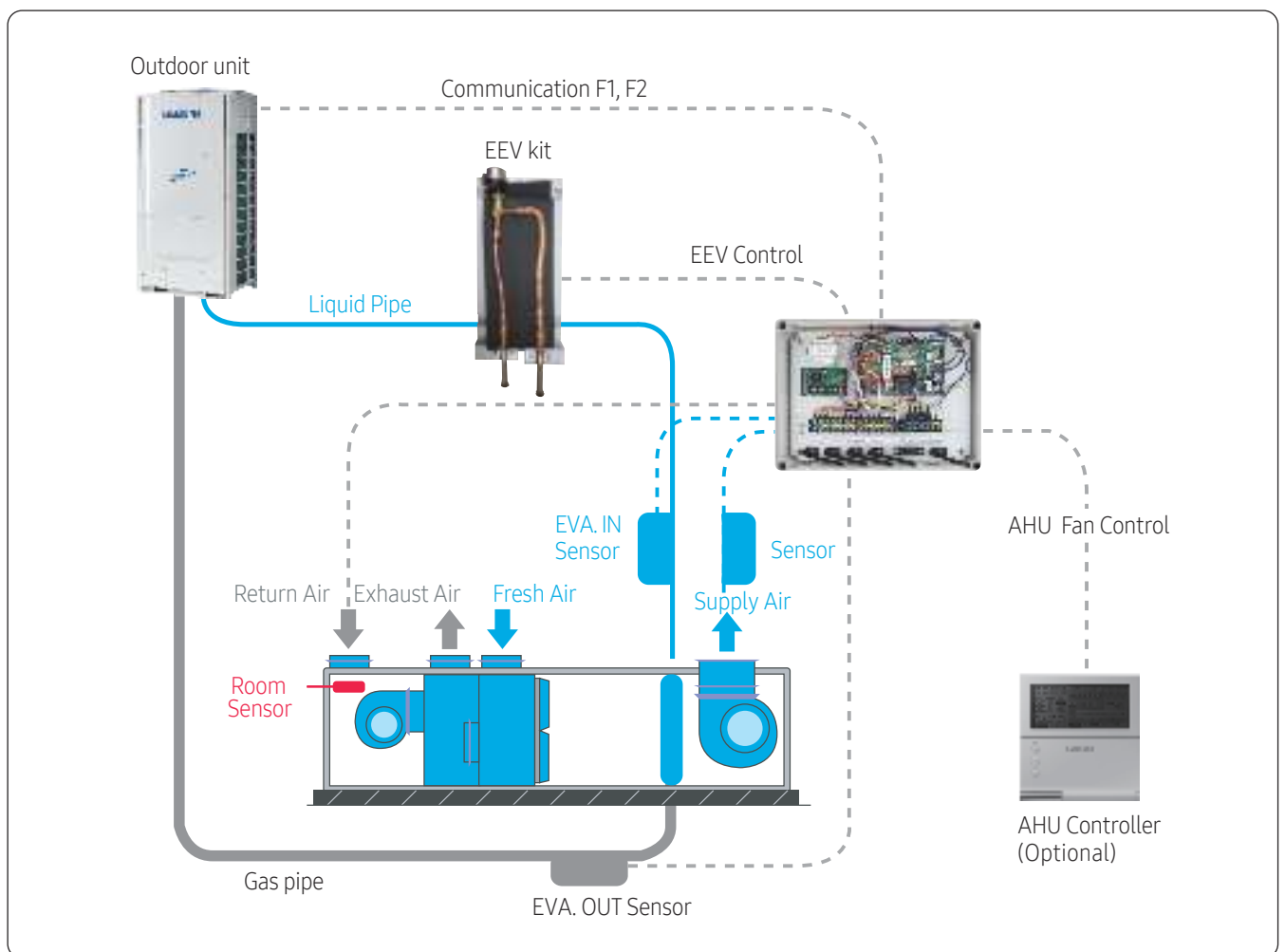

3. AHU (Air Handling Unit) kit

3.1 Feature (MXD-K100XN, for single outdoor unit)

Optimize performance and energy savings with seamless AHU connectivity

Samsung AHU kit allows CAC outdoor units to connect to air handling units (AHUs), which results in energy savings and improved performance and efficiency

Features includes:

- IP54 waterproof rated
- Variable capacity
- 2.6kW - 25kW
- Simple BMS application (0~10V, MXD-K100XN)
- Air temperature control (Location : A or B)

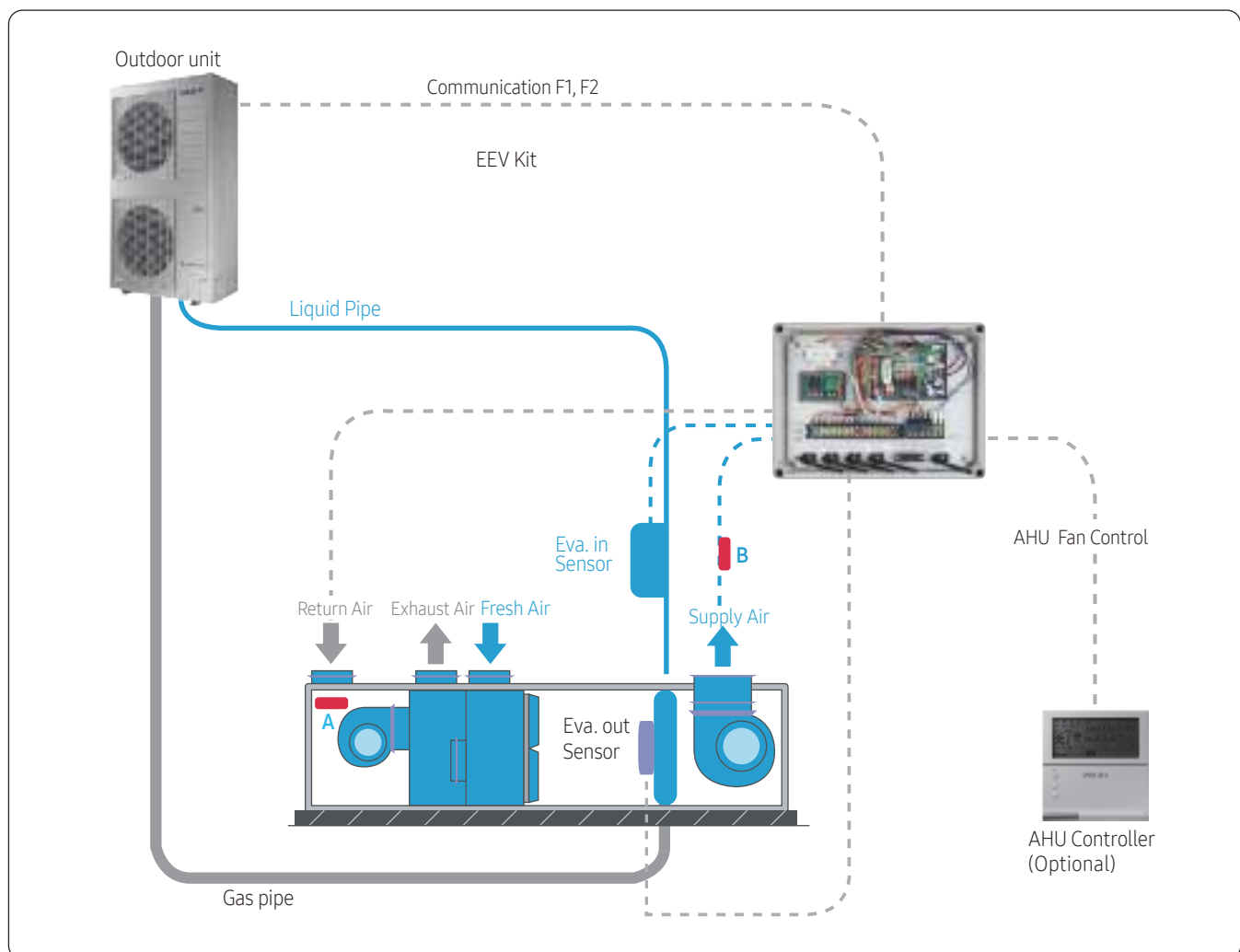

3. AHU (Air Handling Unit) kit

3.1 Feature (MXD-K100XN, for single outdoor unit)

MXD-K***AN / MXD-X000AN

EEV kit

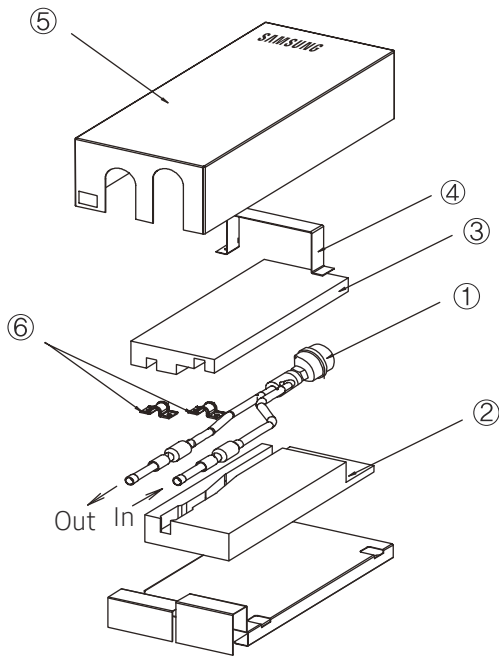

No.	Parts and components
①	EEV body (Coil wire: 2.5/5.0 HP = 2 m 7.5/10.0 HP = 7 m)
②	Lower insulation
③	Upper insulation
④	Holder
⑤	Cover
⑥	Clamp

- Out (to AHU heat exchanger)
- In (from outdoor unit)

* EEV kit is not included in the Model "MXD-X000AN, MCM-D201N, MXD-K100XN".

Control kit

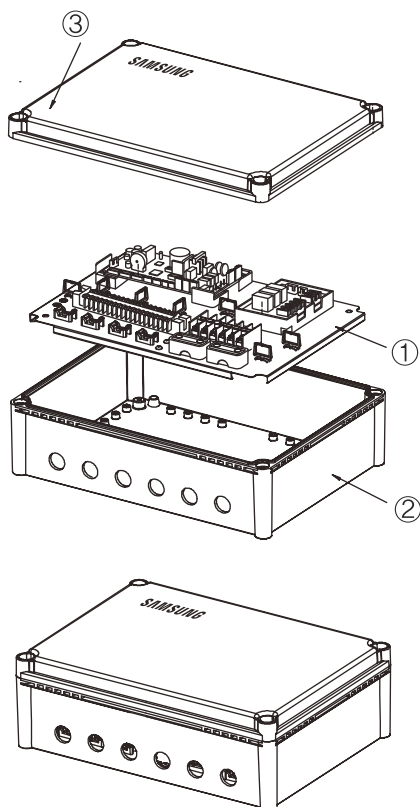

No.	Parts and components
①	Controller board
②	Case
③	Cover

3. AHU (Air Handling Unit) kit

3.3. Spec Sheet

AHU kit (for VRF outdoor unit)

Type			AHU kit					Control kit	EEV kit (Option)	
Model			MXD-K025AN	MXD-K050AN	MXD-K075AN	MXD-K100AN	MXD-X000AN	MCM-D201N (10/20/30/40HP)	MXD-A64K100E (10HP)	
Power Supply		Ø, #, V, Hz	1,2,220- 240,50/60	1,2,220- 240,50/60	1,2,220- 240,50/60	1,2,220- 240,50/60	1,2,220- 240,50/60	1,2,220- 240,50/60	-	
Connectable Outdoor		-	HP/HR	HP/HR	HP/HR	HP/HR	HP/HR	HP	HP	
Design Recommendation	AHU Capacity Allowance	Max.	kW	8.8	17.5	24.9	35	-	35/70 / 105/140	35
			MBH	30	60	85	120	-	119/239 / 358/478	119
		Min.	kW	6.3	12.6	18.9	25.2	-	25.2/50.4/ 75.6/100.8	25.2
			MBH	21.6	43.2	64.8	86.4	-	86.4/172.8/ 259.2/345.6	86.4
	AHU Internal Heat Exchanger Volume Allowance	Max.	cm ³	2,000	4,000	6,000	8,000	-	8,000/16,000 / 24,000/32,000	8,000
		Min.	cm ³	1,200	2,400	4,100	6,100	-	6,100/12,200/ 18,300/24,400	6,100
Piping Connections (EEV kit)	High pressure pipe from outdoor unit	Ø, mm	9.52	9.52	9.52	9.52	-	-	12.7	
		Ø, inch	3/8"	3/8"	3/8"	3/8"	-	-	1/2"	
	High pressure pipe to AHU	Ø, mm	9.52	9.52	9.52	9.52	-	-	12.7	
		Ø, inch	3/8"	3/8"	3/8"	3/8"	-	-	1/2"	
Sensor	EVA. IN	Type / Ø	103HW / 6Ø	103HW / 6Ø	103HW / 6Ø	103HW / 6Ø	-	103HW / 6Ø	-	
		m / mm ²	10m / 2*0.75mm ²	10m/2 * 0.75mm ²	10m/2 * 0.75mm ²	10m/2 * 0.75mm ²	-	7m/2 * 0.75mm ²	-	
	EVA. OUT	Type / Ø	103HW / 7Ø	103HW / 7Ø	103HW / 7Ø	103HW / 7Ø	-	103HW / 7Ø	-	
		m / mm ²	10m/2 * 0.75mm ²	10m/2 * 0.75mm ²	10m/2 * 0.75mm ²	10m/2 * 0.75mm ²	-	7m/2 * 0.75mm ²	-	
	Room	Type / Ø	103HW / Molding	103HW / Molding	103HW / Molding	103HW / Molding	-	PT1000Ω / 4~20mA Field Supply	-	
		m / mm ²	10m/2 * 0.75mm ²	10m/2 * 0.75mm ²	10m/2 * 0.75mm ²	10m/2 * 0.75mm ²	-	-	-	
	Discharge	Type / Ø	103HW / 7Ø	103HW / 7Ø	103HW / 7Ø	103HW / 7Ø	-	PT1000Ω / 4~20mA Field Supply	-	
		m / mm ²	10m/2 * 0.75mm ²	10m/2 * 0.75mm ²	10m/2 * 0.75mm ²	10m/2 * 0.75mm ²	-	-	-	
	Refrigerant	Type	-	R410A	R410A	R410A	R410A	R410A	R410A	
	EEV kit	Type	-	INCLUDED	INCLUDED	INCLUDED	INCLUDED	NOT INCLUDED	NOT INCLUDED	-
EEV Wire length		m	2	2	7	7	-	-	7	
		ft	6.6	6.6	23	23	-	-	23	
Dimensions	EEV kit (W×HxD)	mm	415 x102 x170	415 x102 x170	415 x102 x170	415 x102 x170	-	-	Accessory for MCM-D201N, Ordering Separately (1EA per 10HP)	
		inch	[1'-3 1/4"] x [3 1/2"] x [6 3/4"]	[1'-3 1/4"] x [3 1/2"] x [6 3/4"]	[1'-3 1/4"] x [3 1/2"] x [6 3/4"]	[1'-3 1/4"] x [3 1/2"] x [6 3/4"]	-	-	-	
		inch	6.7 x 16.3 x 4	6.7 x 16.3 x 4	6.7 x 16.3 x 4	6.7 x 16.3 x 4	-	-	-	
	Control Box (W×HxD)	mm	380 x 130 x 280	380 x 130 x 280	380 x 130 x 280	380 x 130 x 280	380 x 130 x 280	385 x 53 x 275	-	
		inch	15.0 x 5.1 x 11.0	15.0 x 5.1 x 11.0	15.0 x 5.1 x 11.0	15.0 x 5.1 x 11.0	15.0 x 5.1 x 11.0	15.2 x 2.1 x 10.8	-	

- Specifications may be subject to change without prior notice for product improvement.
- The AHU design SPEC are base on 10HP test result under Evaporating Temperature: 7°C, Superheat: 1°C, Air temperature: 27°CDB/19°CWB
- The EEV kit, Room/EVA. IN/EVA. OUT/Discharge sensors and Cable-nuts are not included in the Control kit Model "MCM-D201N, MXD-X000AN".
(Pipe inlet/outlet sensor is included in "MCM-D201N, MXD-X000AN".)
- In case of MCM-D201N, EEV kit(Model name : MXD-A64K100E) is need to order 1ea per 10HP separately.
- In terms of AHU, there is a no limitation in capacity.

3. AHU (Air Handling Unit) kit

3.3. Spec Sheet

AHU kit (for single outdoor unit)

Type			AHU Kit					
Model			MXD-K100XN					
Power Supply		Ø, #, V, Hz	1,2,220-240, 50/60					
Connectable Outdoor		-	AC026MXADKH/EU	AC035MXADKH/EU	AC052MXADKH/EU	AC071MXADKH/EU	AC100MXADKH/EU AC100MXADNH/EU	
Design Recommendation	AHU Capacity Allowance	Nominal (Cool)	kW	2.6	3.5	5	7.1	10
			MBH	8.87	11.9	17	24.2	34.1
		Nominal (Heat)	kW	3.4	4	6	8	11.2
			MBH	11.6	13.6	20.5	27.3	38.2
	AHU Internal Heat Exchanger Volume Allowance	Max.	cm ³	800	900	1210	1620	2430
		Min.	cm ³	550	620	840	1130	1690
Sensor	EVA. IN	Type / Ø	103HW / Ø6					
		m/mm ²	10m/2 * 0.75mm ²					
	EVA. Out	Type / Ø	103HW / Ø7					
		m/mm ²	10m/2 * 0.75mm ²					
	Room	Type / Ø	103HW / Molding					
		m/mm ²	10m/2 * 0.75mm ²					
Refrigerant	Type	-	R410A					
Dimensions	Control Box (W x H x D)	mm	380 x 130 x 280					
		inch	15.0 x 5.1 x 11.0					

- Specifications may be subject to change without prior notice for product improvement.
- The AHU design SPEC are base on test result under Air temperature as below.
Cooling : Indoor 27°CDB/19°CWB, Outdoor 35°CDB/24°CWB
Heating : Indoor 20°CDB/15°CWB, Outdoor 7°CDB/6°CWB
- The EEV kit, Room/EVA. IN/EVA. OUT/Discharge sensors and Cable-nuts are not included in the Control kit Model "MCM-D201N, MXD-X000AN".
(Pipe inlet/outlet sensor is included in "MCM-D201N, MXD-X000AN".)
- In case of MCM-D201N, EEV kit(Model name : MXD-A64K100E) is need to order 1ea per 10HP separately.
- In terms of AHU, there is a no limitation in capacity.

3. AHU (Air Handling Unit) kit

3.3. Spec Sheet

5.3. Spec Sheet

AHU kit (for single outdoor unit)

Type			AHU Kit					
Model			MXD-K100XN					
Power Supply		Ø, #, V, Hz	1,2,220-240, 50/60					
Connectable Outdoor		-	AC120MXADKH/EU AC120MXADNH/EU	AC140MXADKH/EU AC140MXADNH/EU	AC180JXAPNH/EU	AC200KXAPNH/EU	AC250KXAPNH/EU	
Design Recommendation	AHU Capacity Allowance	Nominal (Cool)	kW	12	13.4	18	20	25
			MBH	40.9	45.7	61.4	68.2	85.3
		Nominal (Heat)	kW	13	15.5	20	23	27
			MBH	44.3	52.9	68.2	78.5	92.1
	AHU Internal Heat Exchanger Volume Allowance	Max.	cm ³	2830	3240	3700	4600	5400
		Min.	cm ³	1970	2250	2700	3200	4000
Sensor	EVA. IN	Type / Ø	103HW / Ø6					
		m/mm ²	10m/2 * 0.75mm ²					
	EVA. Out	Type / Ø	103HW / Ø7					
		m/mm ²	10m/2 * 0.75mm ²					
	Room	Type / Ø	103HW / Molding					
		m/mm ²	10m/2 * 0.75mm ²					
Refrigerant	Type	-	R410A					
Dimensions	Control Box (W x H x D)	mm	380 x 130 x 280					
		inch	15.0 x 5.1 x 11.0					

- Specifications may be subject to change without prior notice for product improvement.
- The AHU design SPEC are base on test result under Air temperature as below.
Cooling : Indoor 27°CDB/19°CWB, Outdoor 35°CDB/24°CWB
Heating : Indoor 20°CDB/15°CWB, Outdoor 7°CDB/6°CWB
- The EEV kit, Room/EVA. IN/EVA. OUT/Discharge sensors and Cable-nuts are not included in the Control kit Model "MCM-D201N, MXD-X000AN".
(Pipe inlet/outlet sensor is included in "MCM-D201N, MXD-X000AN".)
- In case of MCM-D201N, EEV kit(Model name : MXD-A64K100E) is need to order 1ea per 10HP separately.
- In terms of AHU, there is a no limitation in capacity.

3. AHU (Air Handling Unit) kit

3.4. Dimensional drawings

Dimensional drawings

MCM-D201N

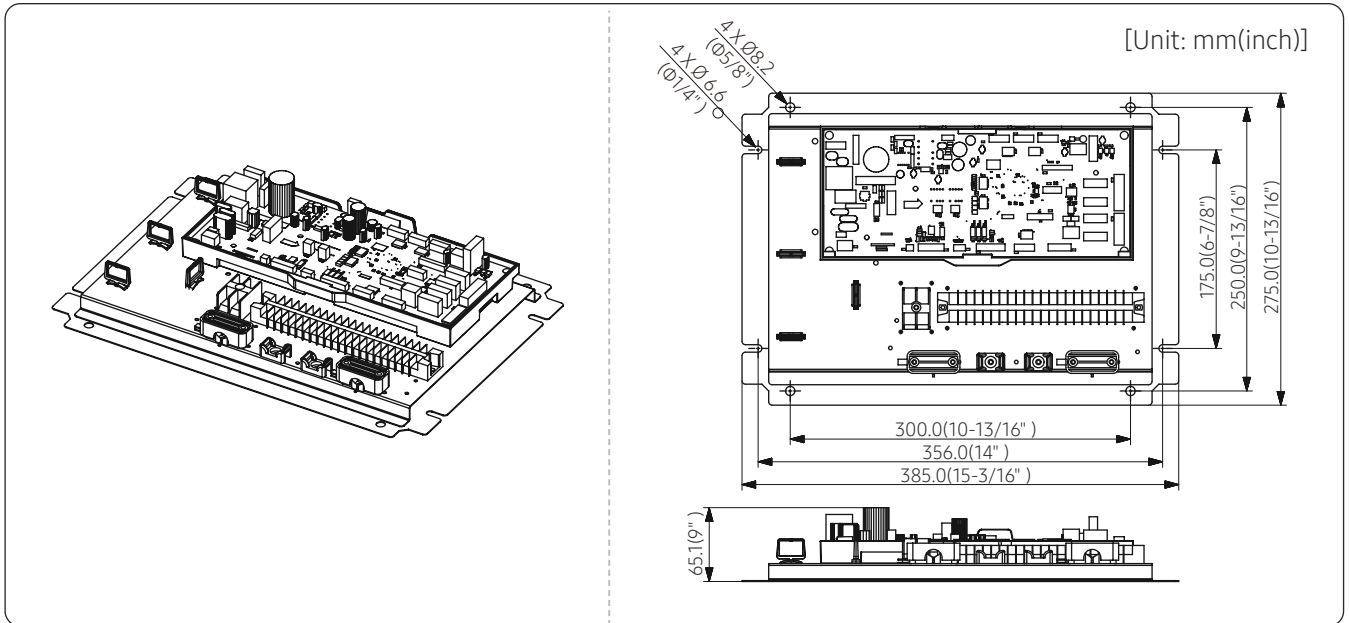

EEV kit : Accessory (Ordered separately)

For detailed information of EEV installation, refer to the installation manual of ASS'Y EEV (MXD-A64K100E) which you need to purchase additionally.

MXD-A64K100E

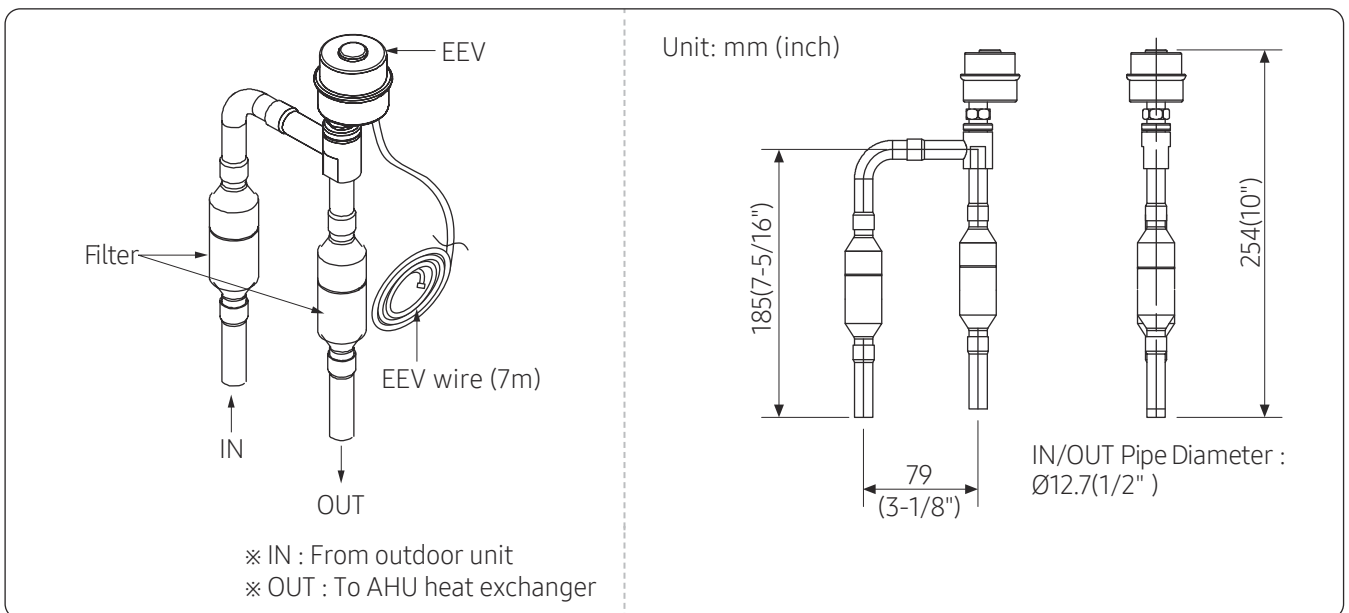

※ IN : From outdoor unit
 ※ OUT : To AHU heat exchanger

3. AHU (Air Handling Unit) kit

Wiring drawings

MXD-K***AN / MXD-X000AN / MXD-K100XN

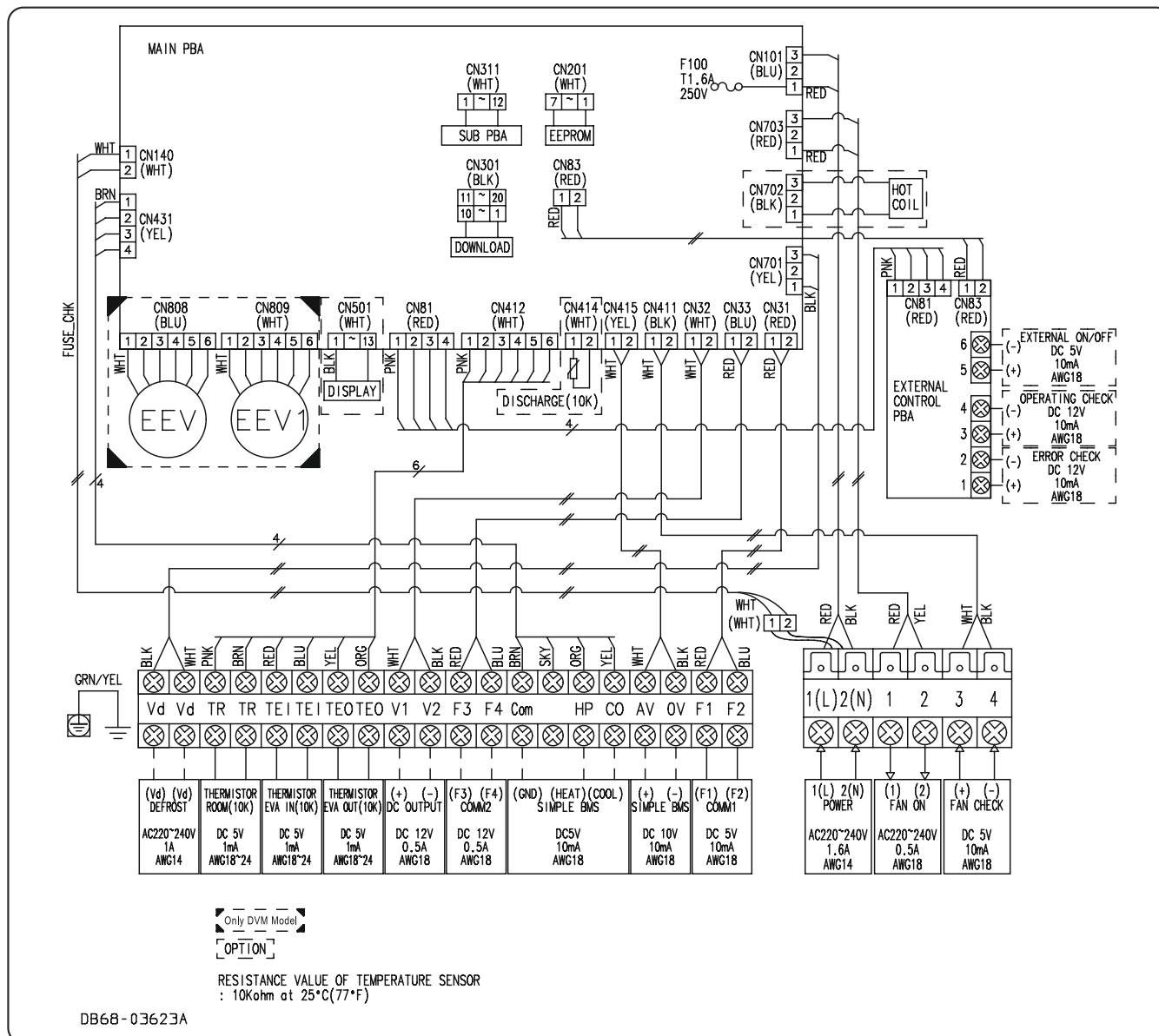

EEV	Electronic Expansion Valve	EEV1	Electronic Expansion Valve	Vd	Defrost Signal(AC)
TR	Room Temperature	TEI	EVAP. IN Temperature	TEO	EVAP. OUT Temperature
Com/HP/CO/AV/OV	Simple BMS				

NOTE

- Symbols show as follow : BLK: black, RED: red, BLU: blue, WHT: white, YEL: yellow, BRN: brown, SKY: skyblue: GRN: green
- Protective earth(SCREW) , CN *: connector, $\frac{N}{x}$: The quantity

3. AHU (Air Handling Unit) kit

Wiring drawings

MCM-D201N

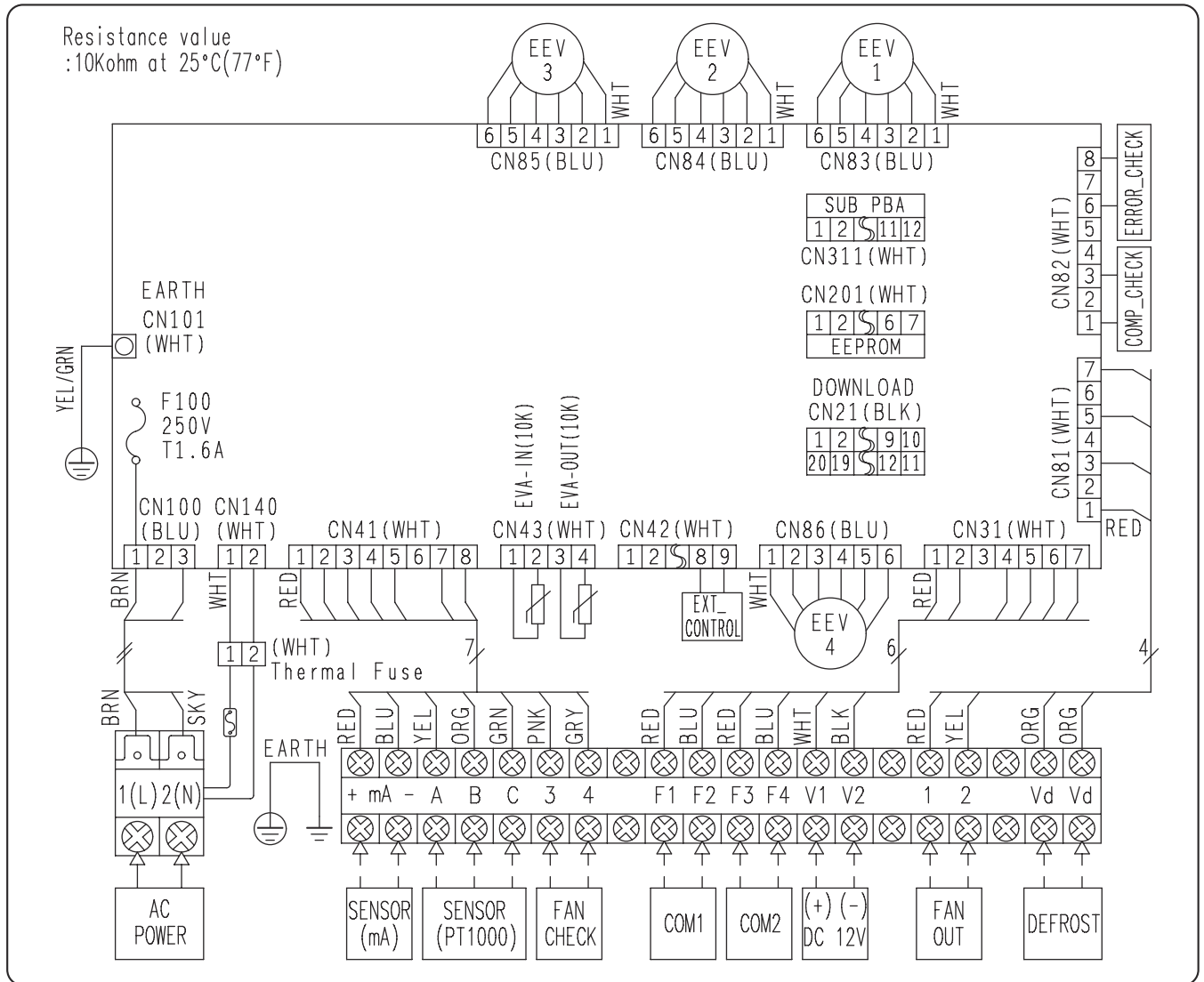

EEV1/2/3/4	Electronic expansion valve	Sensor(mA)	4~20mA Sensor(-50~50°C, Field Supply)
Vd	Defrost Signal (AC)	Sensor(PT1000)	PT1000Ω Sensor (-30~50°C, Field Supply)

NOTE

- Symbols show as follow : BLK: black, RED: red, BLU: blue, WHT: white, YEL: yellow, BRN: brown, SKY: skyblue: GRN: green
- Protective earth(SCREW), CN *: connector, $\frac{N}{x}$: The quantity

4. FCU (Fan Coil Unit) Kit

MIM-F00N

Features

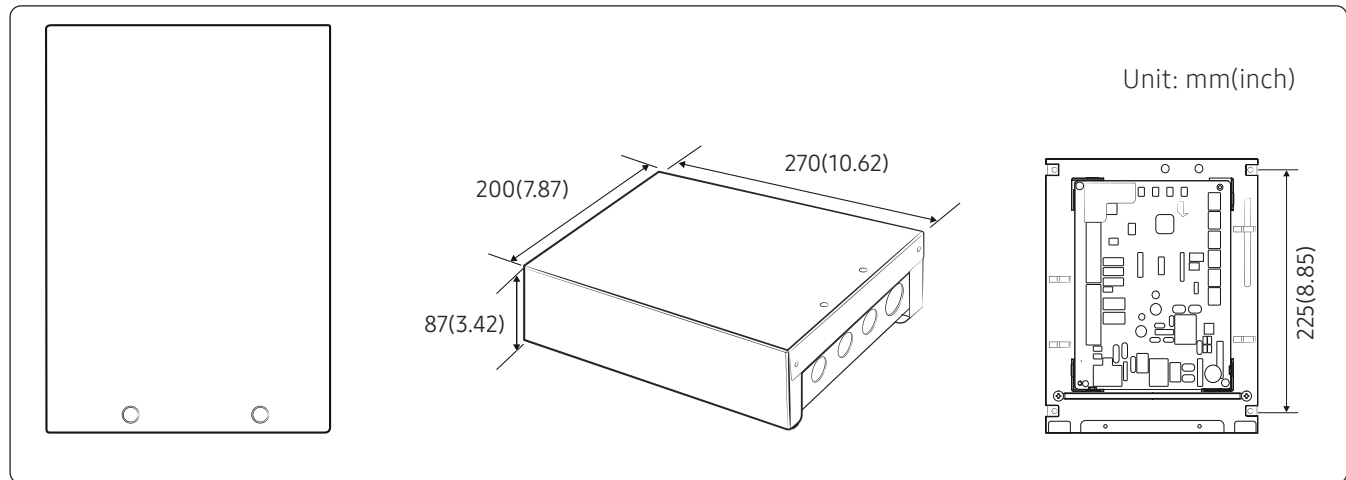

- Communication and control interfacing kit between 3rd party FCU and Samsung control system.
- Possible to use wired remote controller
- Possible to use DMS2.5, Touch centralized controller
- Provides external contact input
- Outputs control signal for FCU fan.
- Outputs control signal for Water valve .

Product specification

Communication	RS485 x 1 (F1/F2) 2-wire PLC x 1 (F3/F4)
Max. length of connection	RS485 – 1000m(3280ft) 2-wire PLC - 100m(328ft)

Power & cable specification

Europe

Power Supply	Power cable	Ground wire	Communication cable	ELCB
AC220 - 240V~ 50Hz, 1Ph	Min. 2.5 mm2 (0.0039 inch2)	Min. 2.5 mm2 (0.0039 inch2)	Min. 0.75 mm2(0.0012 inch2)	15A

Part	Rated Capacity
Fan (High, Mid, Low)	AC220 - 240V~ 50Hz, 1Ph, 1A
Water Valve	AC220 - 240V~ 50Hz, 1Ph, 0.5A

USA

Power Supply	MCA	MOP
AC 208 - 230 V~ 60 Hz, 1 Ph	2.75	15A

Part	Rated Capacity
Fan (High, Mid, Low)	AC208 - 230V~ 60Hz, 1Ph, 1A
Water Valve	AC208 - 230V~ 60Hz, 1Ph, 0.5A

4. FCU (Fan Coil Unit) Kit

MIM-F00N

Product specification

Power & cable specification

DC Wire

Part	Rated Capacity
Remote controller	DC 12V
External contact	Zero voltage contact input
Sensor cable	NTC./10 kΩ 25°C

Compatible controller

Wired remote controller	MWR-WE11N, MWR-SH10N
Interface module	MIM-F10N
DMS2.5	MIM-DO1AN
BACnet GW	MIM-B17BN
LonWorks GW	MIM-B18BN

Description of parts

Electrical wiring diagram

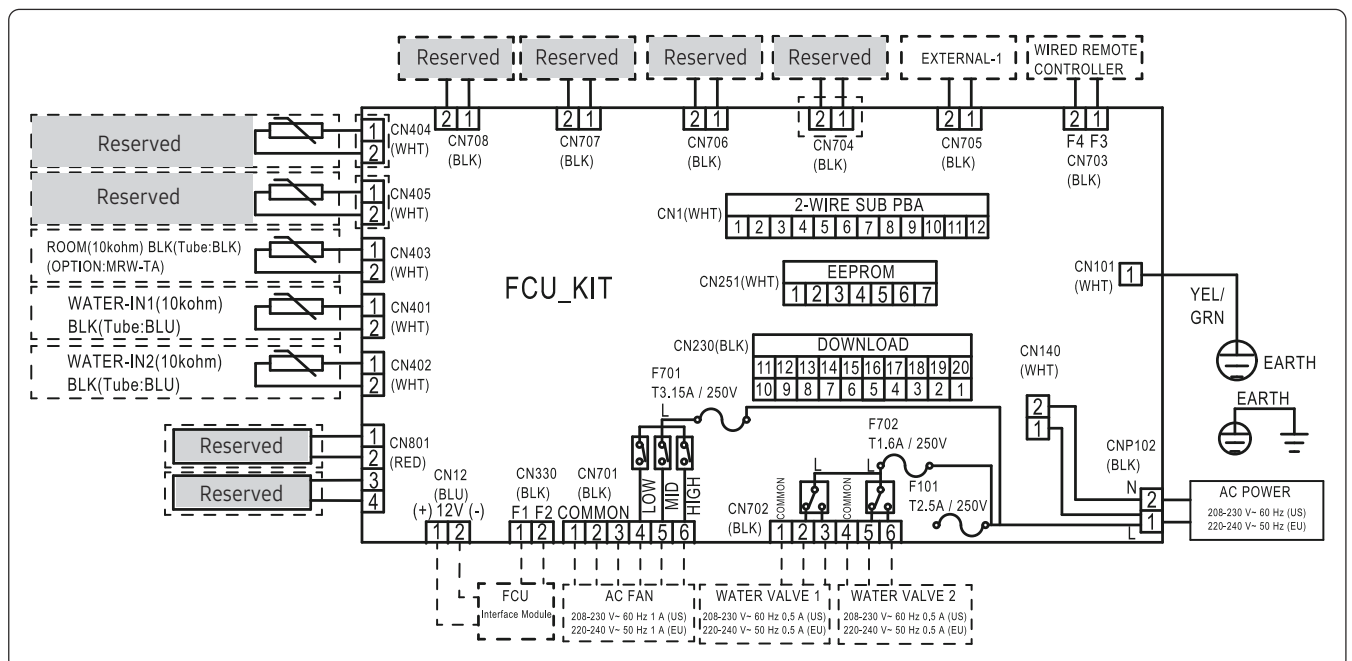

4. FCU (Fan Coil Unit) Kit

MIM-F00N

Connection diagram

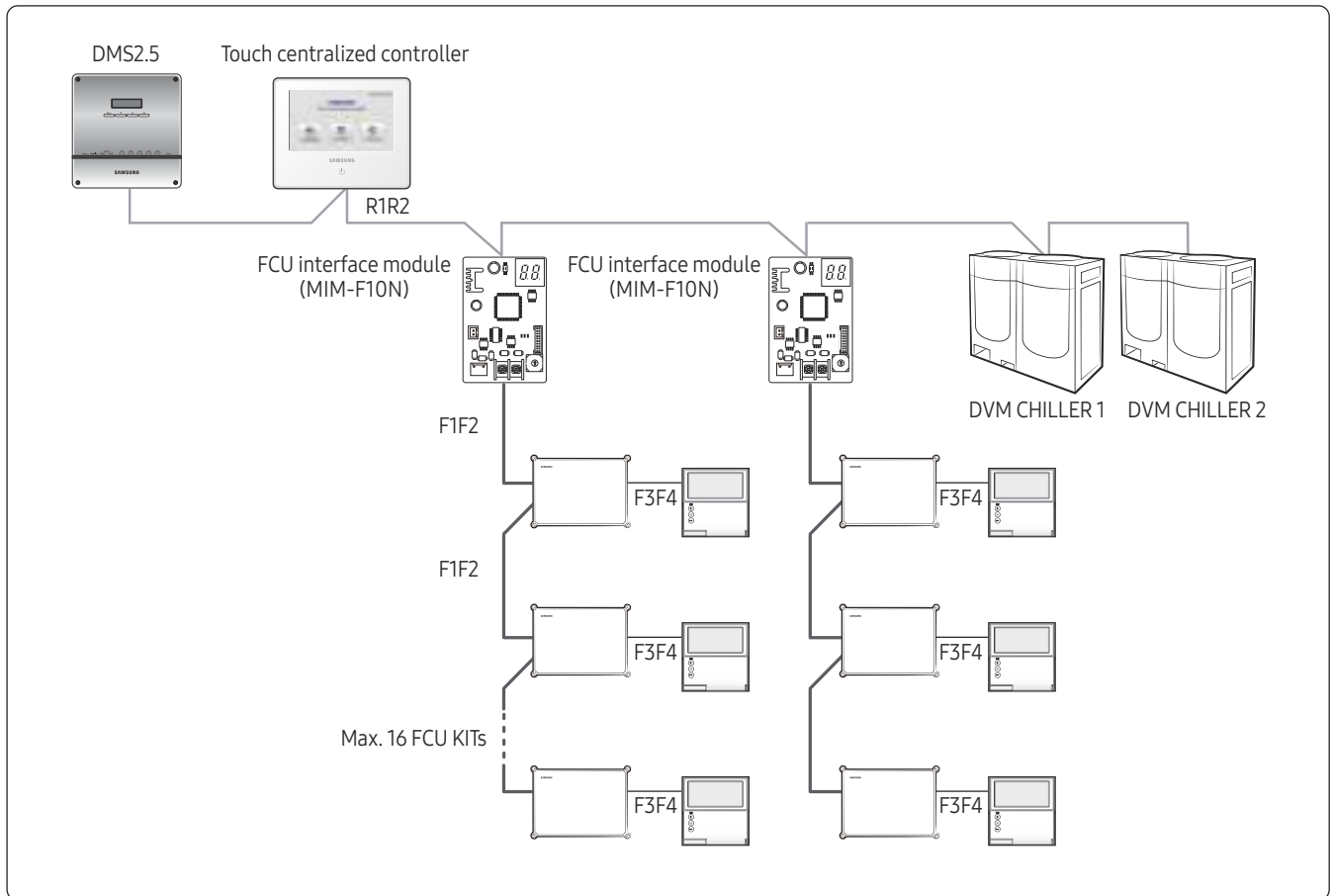

4. FCU (Fan Coil Unit) Kit

MIM-F00N

Individual control of FCU

- Install FCU and FCU KIT by 1 to 1.
- Maximum number of FCU KITs that can be installed to a FCU interface module is 16.

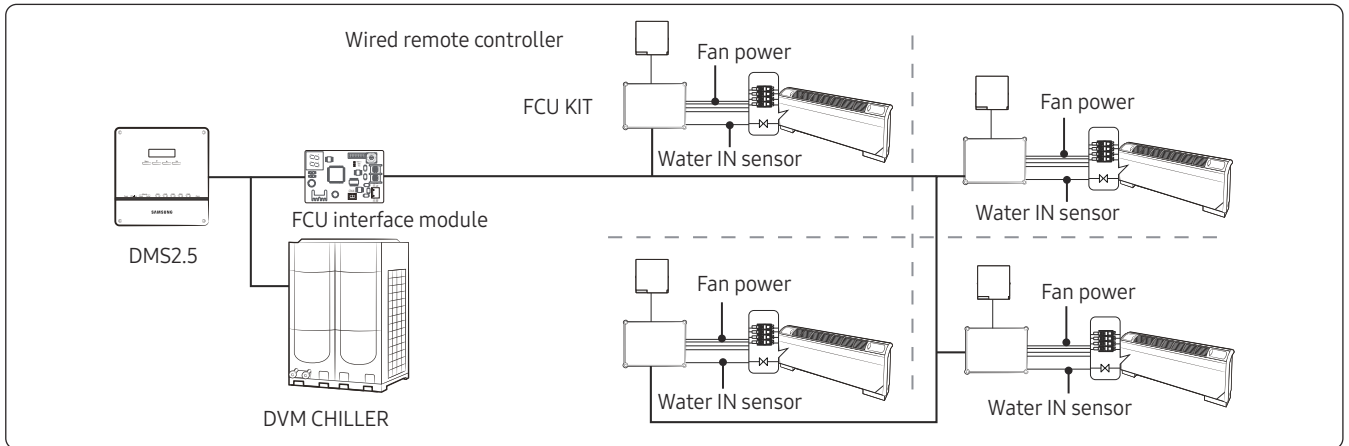

- Indoor temperature sensor must be installed to control FCU. Use either wired remote controller built-in sensor or external room sensor (MRW-TA).
 - Option setting value should be changed in service setting mode of wired remote controller after installing the remote controller. (Main menu 1, Sub menu 1, SEG 1, value 1)
 - In case of using external temperature sensor (optional), value of SEG24 (FCU KIT external indoor temperature sensor) of O5 series installation option should be set as 1.
- Water sensor should be attached to inlet pipe (1) for 2 pipe system (Water In), and each inlet pipe (2) for 4 pipe system (Cooling pipe in Heating pipe in.)
- Maximum number of FCU KITs that can be installed and controlled simultaneously by a wired remote controller is 16.

4. FCU (Fan Coil Unit) Kit

MIM-F00N

Integrated control of FCU

- Install FCUs and FCU KIT by multiple FCUs to 1 FCU KIT.

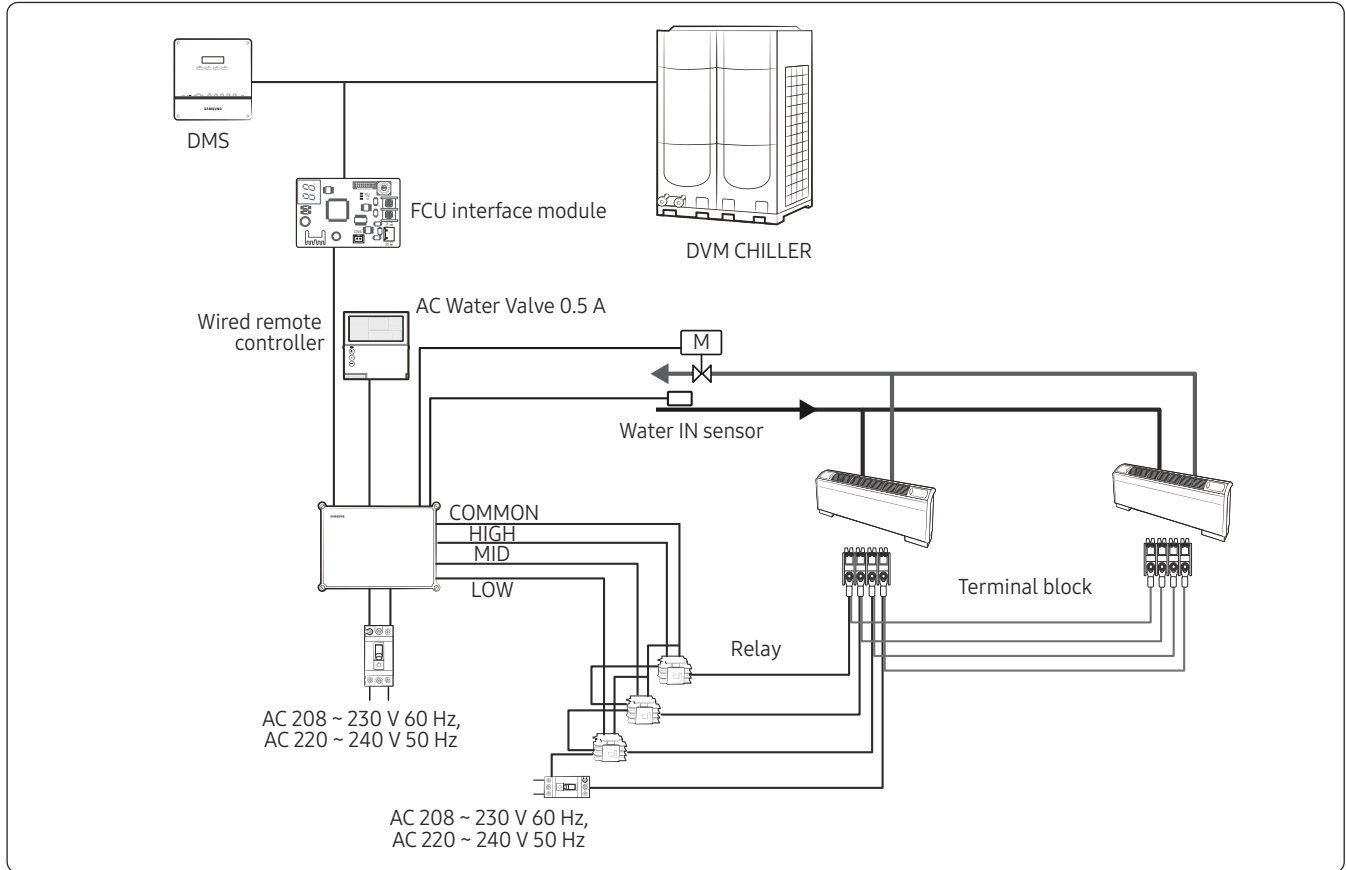

- National electric appliance safety standard should be applied for relay installation and capacity and power cable connection of FCU terminal block.

4. FCU (Fan Coil Unit) Kit

MIM-F00N

Wiring

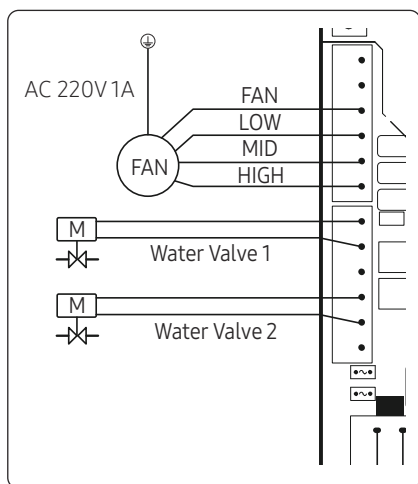
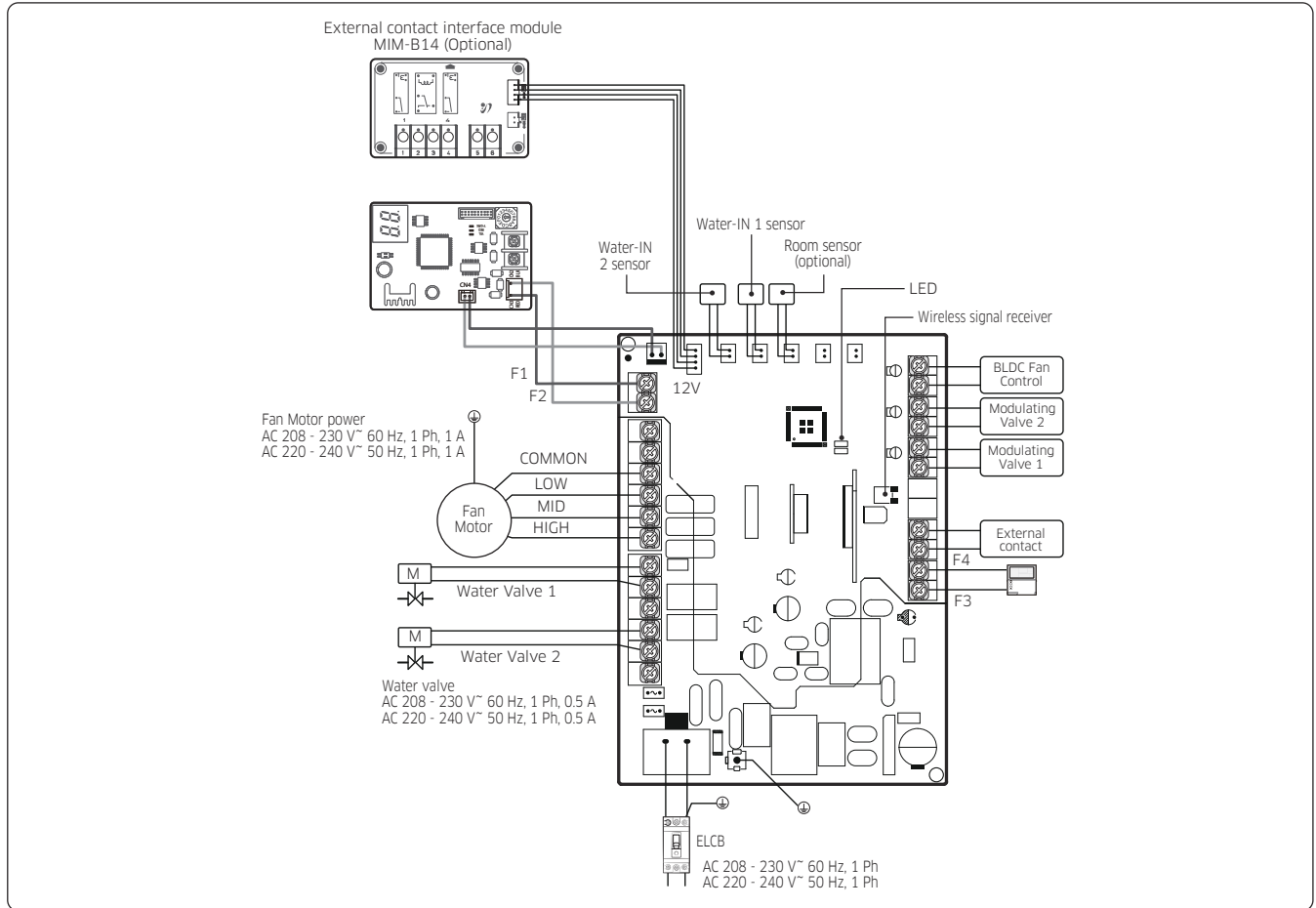

Fan: Must use below specification fan.

- For direct power supply from FCU KIT, fan motor must work at AC 208 - 230V ~ 60 Hz, AC 220 - 240V ~ 50Hz and 1A or low. Otherwise, install relay for external power supply to the fan motor.

Water Valve: 2 Way or 3 Way solenoid valve

- 2/3 way solenoid valve is a type that works at AC 208 - 230V ~ 60Hz, AC 220 - 240V ~ 50Hz and supports product with 0.5 A or low.

Pipe type	Power output according to operation mode	AC 220 V output (Max 0.5 A)	Note
2-pipe	Cooling/ Heating	Thermo ON	1-2
		Thermo OFF	1-3
4-pipe	Cooling	Thermo ON	1-2
		Thermo OFF	1-3
	Heating	Thermo ON	4-5
		Thermo OFF	4-6

- Connect 3 Way valve power cable according to value of operation mode power output.
- Select each valve that is below 0.5 A of operation current.
- Installation option setting(05series, SEG 14) is required to define 2 pipe or 4 pipe system.

4. FCU (Fan Coil Unit) Kit

MIM-F00N

Water IN sensor

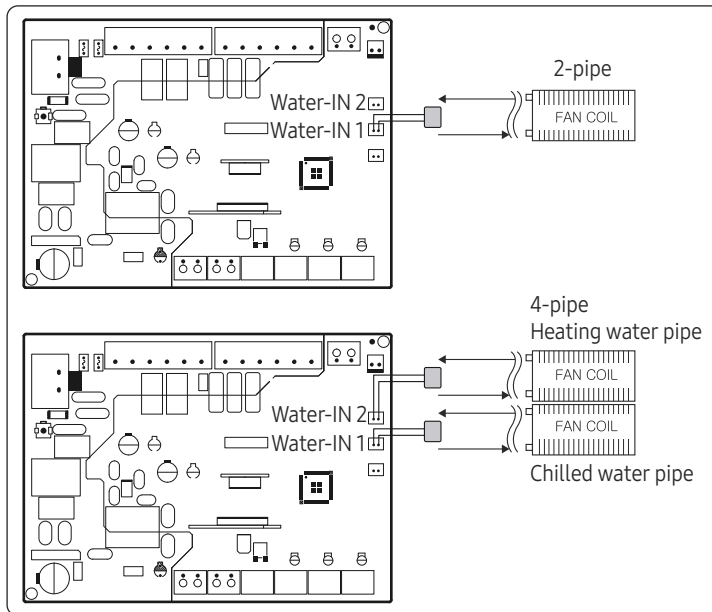

- When using 4-pipe system, set SEG14, of 05 series installation option as 1.
- In case of opposite installation of water pipe 1, 2 sensor in 4 pipe system, error(pipe block) will be occurred in 30 minutes of operation (E992 or E993).

Pipe type	Sensor connection in PBA (FCU KIT)	Sensor location (Pipe)
2-pipe	Water-IN 1	Water pipe inlet
4-pipe	Water-IN 1	Chilled water pipe inlet
	Water-IN 2	Heating water pipe inlet

Wired remote controller

- 1 FCU KIT can connect 1 wired remote controller.
- 1 wired remote controller can connect Max.16 FCU KITs.
 - ※ Wired remote controller can control below function of FCU KIT.
- On/Off
- Operation mode
- Temperature setting
- Fans speed. (High, Mid, Low)
- Schedule

FCU interface module

- 1 FCU interface module can connect Max.16 FCU KITs.

4. FCU (Fan Coil Unit) Kit

MIM-F00N

External contact connection

- In case of connecting external contact, set SEG14 of installation option according to the table.

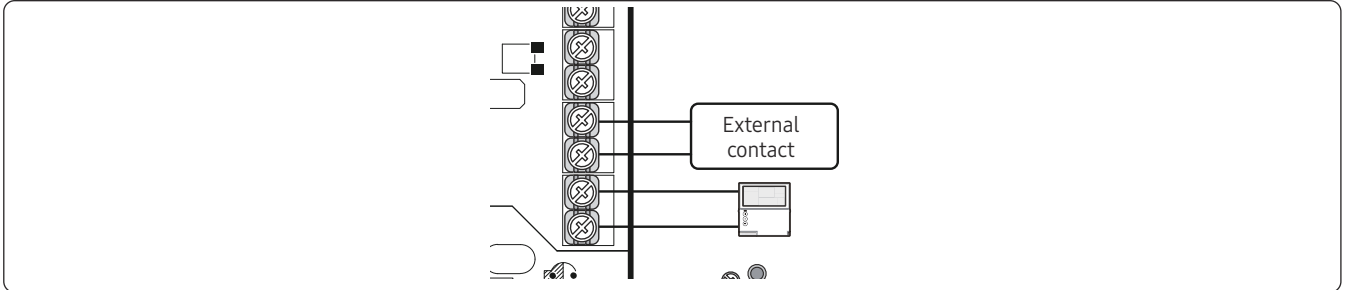

Installation option SEG14	External contact status	
	Open	Close
0	Disuse	Disuse
1	FCU OFF, remote control possible	ON, remote control possible
2	FCU OFF, remote control impossible	Remain OFF, remote control possible
3	FCU OFF, remote control impossible	Remain operation status of FCU before external contact open <ul style="list-style-type: none"> Operation ON of FCU before external contact open: FCU ON Operation OFF of FCU before external contact open: FCU OFF Remote control possible

Option room sensor (Model: MRW-TA)

- In case of installing room sensor as option, set installation option according to the table. (05series, SEG24 = 1)

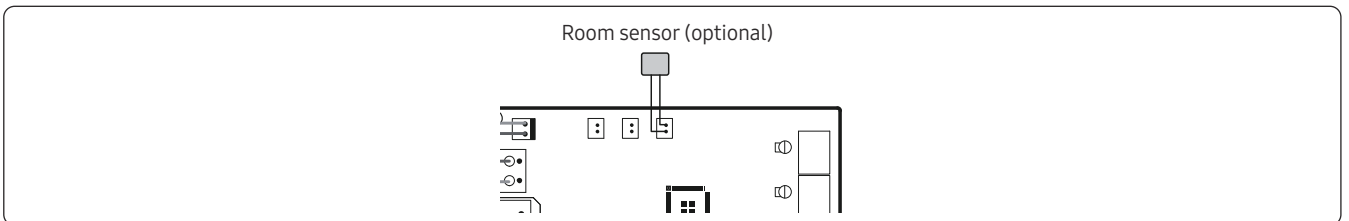

⚠ CAUTION

- Use either wired remote controller with built-in room sensor or external room sensor (MRW-TA) must be installed.

Optional external contact interface module (MIM-B14)

- If you need an external contact control (for indoor unit ON/OFF, external heater control, or pump control), use an external contact interface module.

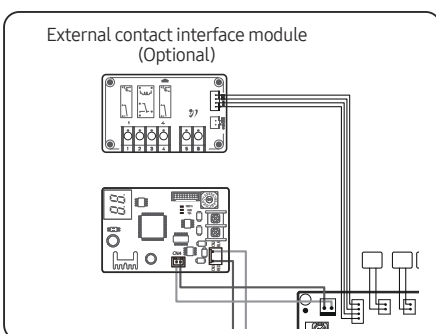

5. UCK (Universal Communication Kit)

5.1. Feature

1 Provides a communication kit that enables normal operation when connecting an outdoor unit (VRF) to a 3rd party indoor unit.

Components: ① Control kit + ② EEV kit

2 Enhances the compatibility with a 3rd party indoor unit and provides advanced functions.

Optimized to perform the following functions:

- ① : Control the Fan (H/M/L)
- ② : Connect to an economizer.
- ③ : Control the variable outputs of a ventilation damper.
- ④ : Control an enthalpy sensor.
- ⑤ : Provide an applicability to any additional loads.
- ⑥ : Use 24 VAC power supply.

3 System Diagram

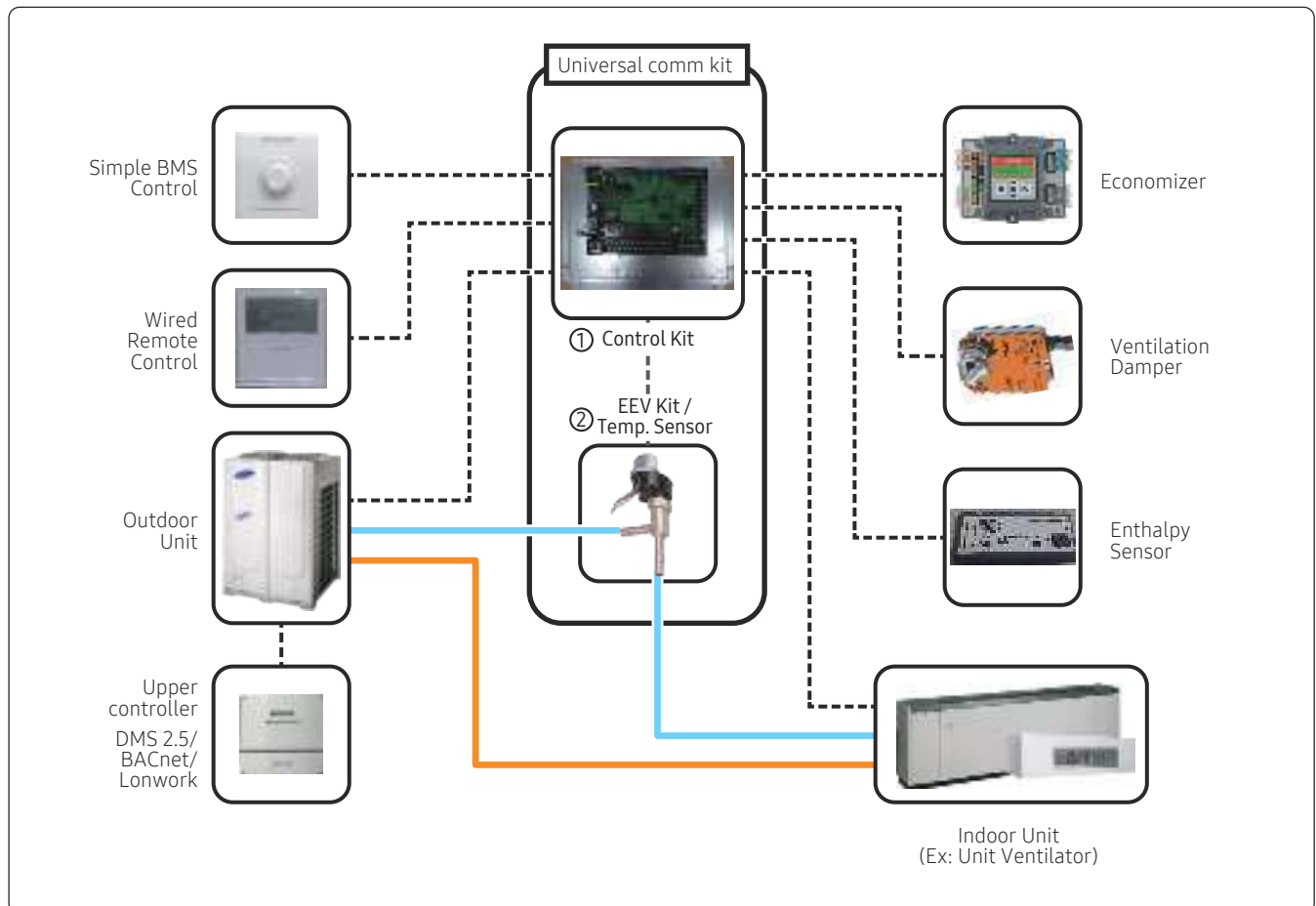

5. UCK (Universal Communication Kit)

5.2. Combination & Line-up Table

1 Setting of the indoor unit capacity and EEV model selection (SEG 20 of the installation option 05 series)

Display	Rated Capacity	Capacity Range	Heat Exchanger	Control kit	Number of	EEV kit	Number of
	(Btu/h)	(Btu/h)	Volume(in3)		Control kit		EEV kit
0	12k	7k to 18k	28 to 71	MCM-D211UN	1	MXD-A24K100E	1
1	12k	7k to 18k	28 to 71		1		1
2	24k	18k to 30k	71 to 118		1	MXD-A32K100E	1
3	36k	30k to 42k	118 to 165		1	MXD-A40K100E	1
4	48k	42k to 60k	165 to 236		1		1
5	60k	60k to 72k	236 to 283		1	MXD-A64K100E	1
6	72k	72k to 96k	283 to 378		1		1
7	96k	96k to 144k	378 to 566		1		1
8	144k	144k to 192k	566 to 755		1		2
9	192k	192k to 240k	755 to 944		1		2
A	240k	240k to 288k	944 to 1133		1		3
B	288k	288k to 336k	1133 to 1322		1		3
C	336k	336k to 384k	1322 to 1510		1		4
D	384k	384k to 480k	1510 to 1725		1		4

2 Outdoor unit combination

	Universal Comm. kit	
	HP	HR
DVM S	○	○
DVM S water	○	○
DVM S Eco	○	○

3 Part combination

	Part combination of the universal Comm. Kit										
	EEV	Thermister	Fan Motor	Fan check	Economizer	Damper	Enthalpy	Simple BMS	Heater	PT1000	Defrost
Mandatory (Product supplied)	○	○									
Mandatory (Field supplied)			○								
Optional (Field supplied)				○	○	○	○	○	○	○	○

5. UCK (Universal Communication Kit)

5.3. Product Specification

1 Composed of a single Control kit and 4 EEV kits

Type			Control Kit	EEV Kit	EEV Kit	EEV Kit	EEV Kit	
Model Name			MCM-D211UN	MXD-A24K100E	MXD-A32K100E	MXD-A40K100E	MXD-A64K100E	
Power Supply		Φ, #, V, Hz	24VAC	-	-	-	-	
Applied outdoor unit Type		-	Heat Pump / Heat Recovery	Heat Pump / Heat Recovery	Heat Pump / Heat Recovery	Heat Pump / Heat Recovery	Heat Pump / Heat Recovery	
Performance	EEV(EDM)		-	Φ 2.4mm	Φ 3.2mm	Φ 4.0mm	Φ 6.4mm	
	Refrigeration Ton		TON	1/2/4/8/17/25/34	1	2	4	8
	Capacity	Cooling (Min)	kW	-	-	-	-	-
			Btu/h	7000	7000	18000	30000	60000
		Cooling (Max)	kW	-	-	-	-	-
			Btu/h	384000	18000	30000	60000	144000
		Heating (Min)	kW	-	-	-	-	-
			Btu/h	8500	8500	22000	34000	64000
Heating (Max)	kW	-	-	-	-	-		
	Btu/h	432000	22000	34000	64000	108000		
AHU Internal Heat Exchanger Volume Allowance		Min	in3	28	28	71	118	236
		Max	in3	1725	71	118	236	566
EEV in/out Connection	Liquid Pipe		Φ, inch	-	3/8	1/2	3/8	1/2
	Gas Pipe		Φ, inch	-	3/8	1/2	3/8	1/2
Field Wiring	Power Source Wire		mm2	-	-	-	-	-
	Transmission Cable		mm2	-	-	-	-	-
External Dimension	Net Weight		kg	1.7	0.29	0.46	0.36	0.66
			lb	3.75	0.64	1.01	0.79	1.46
	Shipping Weight		kg	3.54	0.48	0.64	0.56	0.85
			lb	7.8	1.06	1.41	1.23	1.87
	Net Dimensions (WxHxD)		mm	385*275*56	243*70*42	250*70*42	250*70*42	259*117*42
			in	15.16*10.83*2.2	9.57*2.76*1.65	9.84*2.76*1.65	9.84*2.76*1.65	10.20*4.61*1.65
	Shipping Dimensions (WxHxD)		mm	399*289*138	276*121*69	276*121*69	276*121*69	276*121*69
			in	15.71*11.38*5.43	10.87*4.76*2.72	10.87*4.76*2.72	10.87*4.76*2.72	10.87*4.76*2.72

5. UCK (Universal Communication Kit)

5.4. Technical drawings

Dimensional Drawings

1 Control Kit

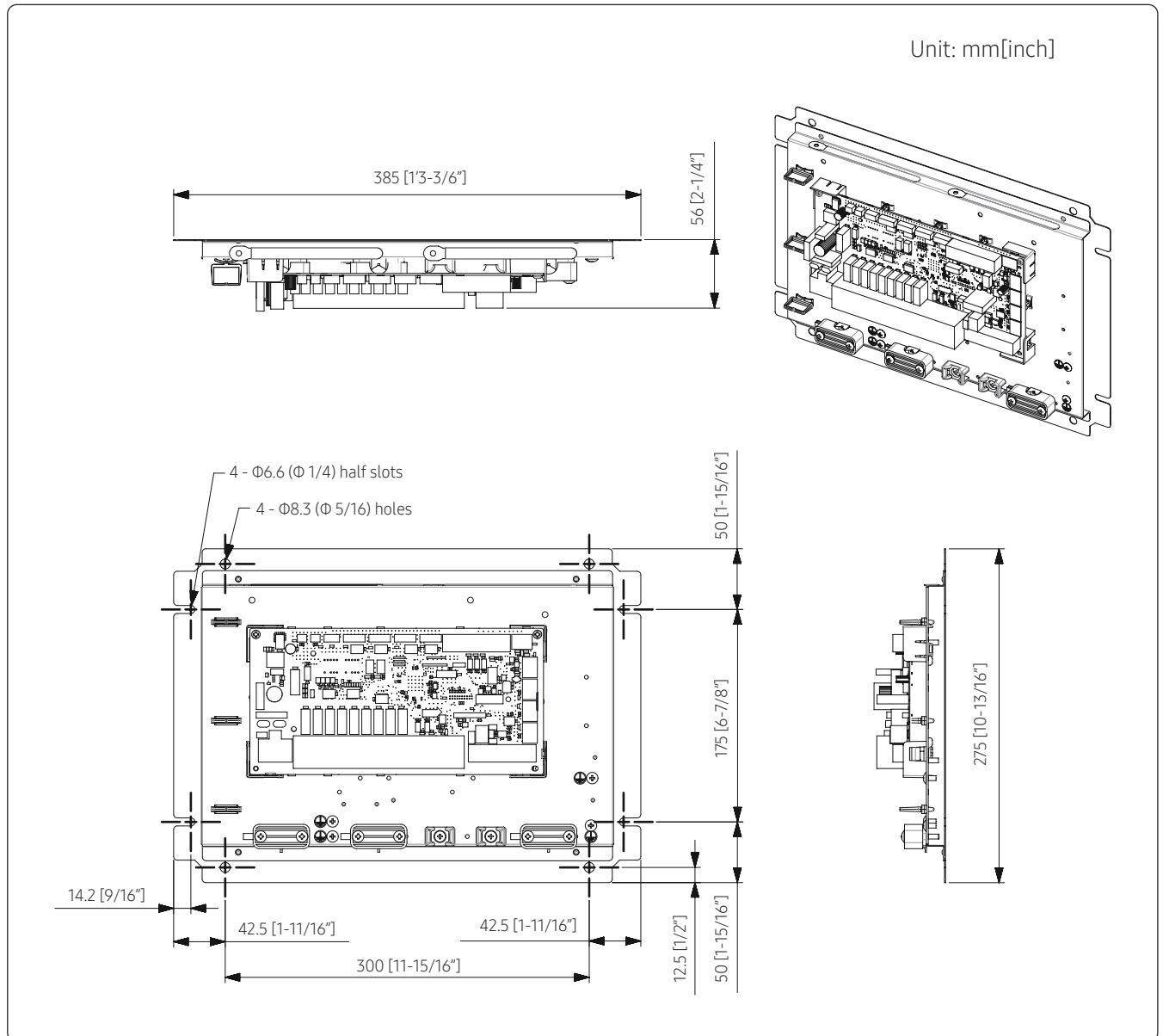

5. UCK (Universal Communication Kit)

5.4. Technical drawings

1 EEV Kit (Electronic Expansion Valve)

MXD-A64K100E
MXD-A32K100E

MXD-A40K100E
MXD-A24K100E

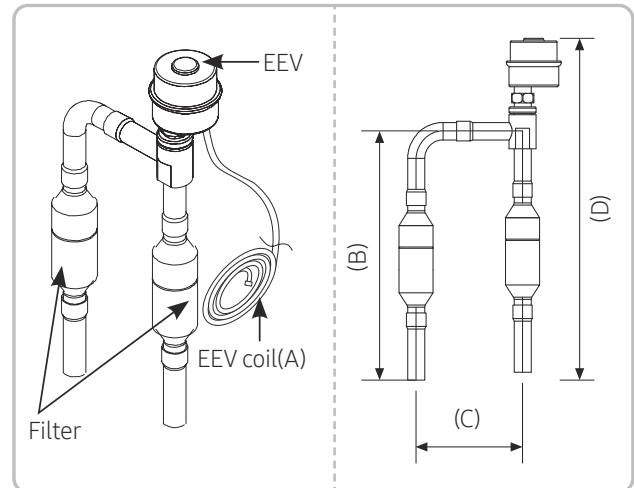
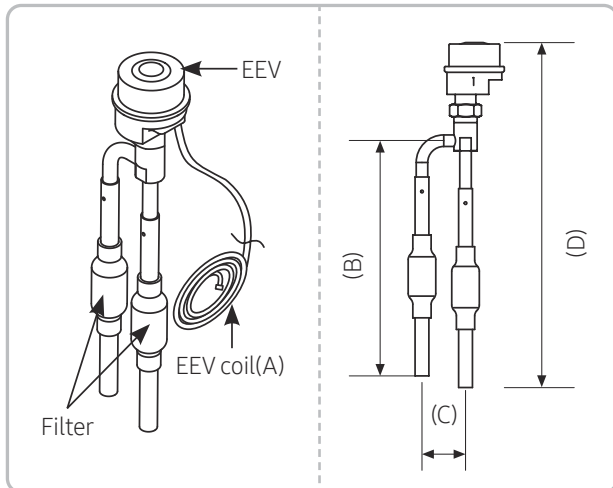

Model	A [ft(m)]	B [inch(mm)]	C [inch(mm)]
MXD-A64K100E	22.97 (7)	7.28 (185)	3.03 (77)
MXD-A40K100E	6.56 (2)	6.57 (167)	1.34 (34)
MXD-A32K100E	6.56 (2)	7.28 (185)	2.91 (74)
MXD-A24K100E	3.28 (1)	6.38 (162)	1.18 (30)

5. UCK (Universal Communication Kit)

5.4. Technical drawings

Piping Drawings

1 Cooling operation

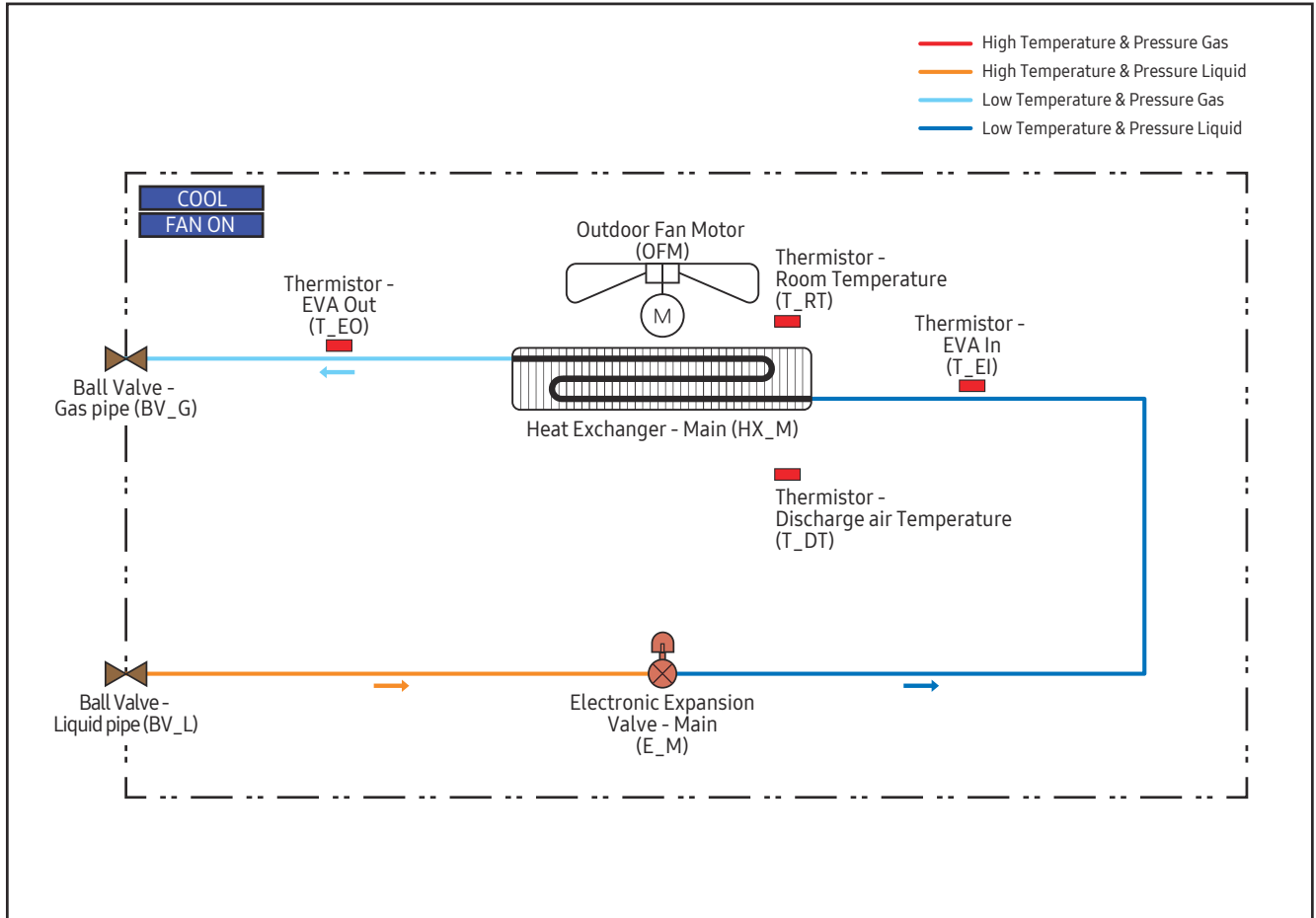

5. UCK (Universal Communication Kit)

5.4. Technical drawings

Piping Drawings

1 Heating operation

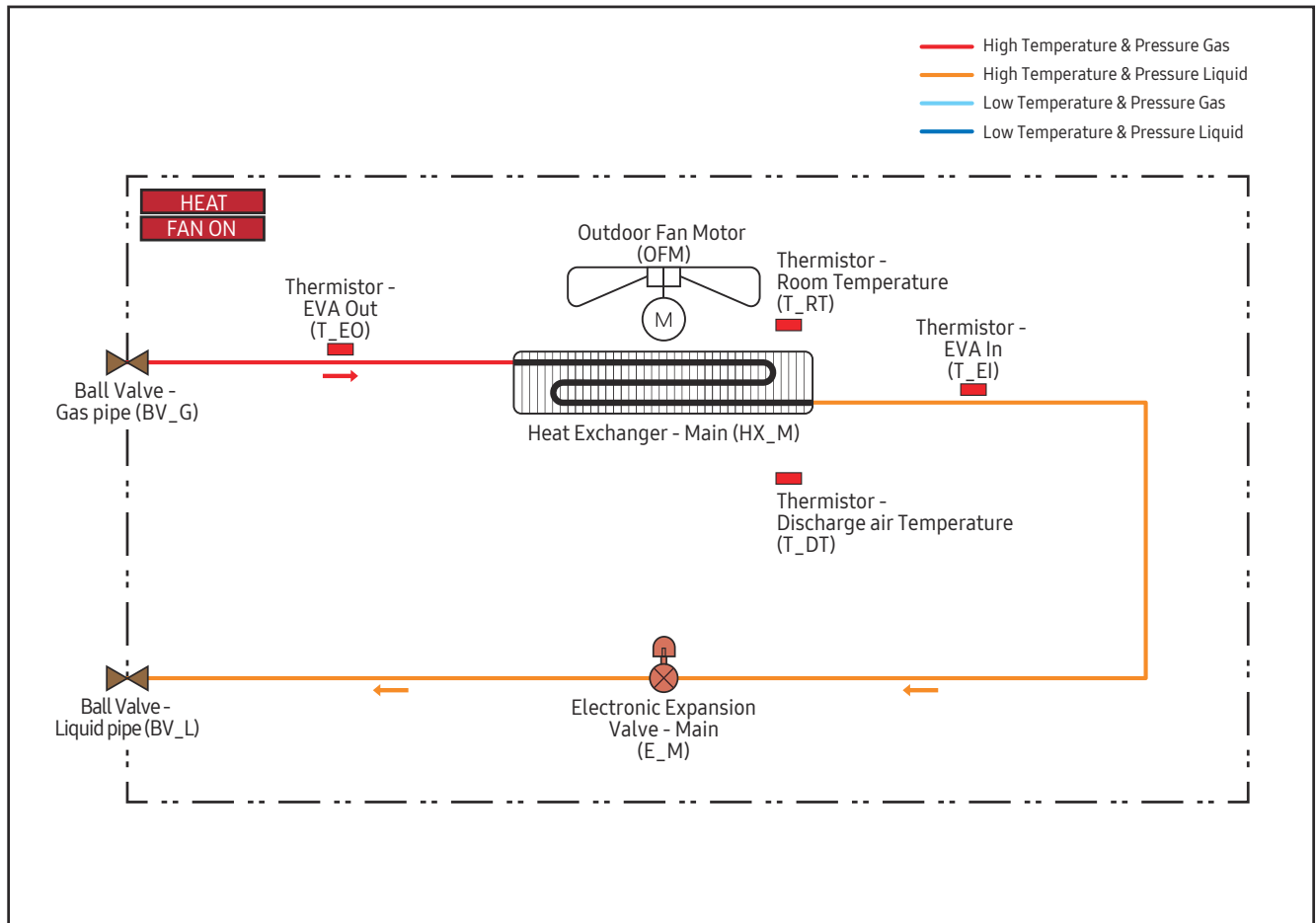

5. UCK (Universal Communication Kit)

5.4. Technical drawings

Piping Drawings

1 Free cooling operation

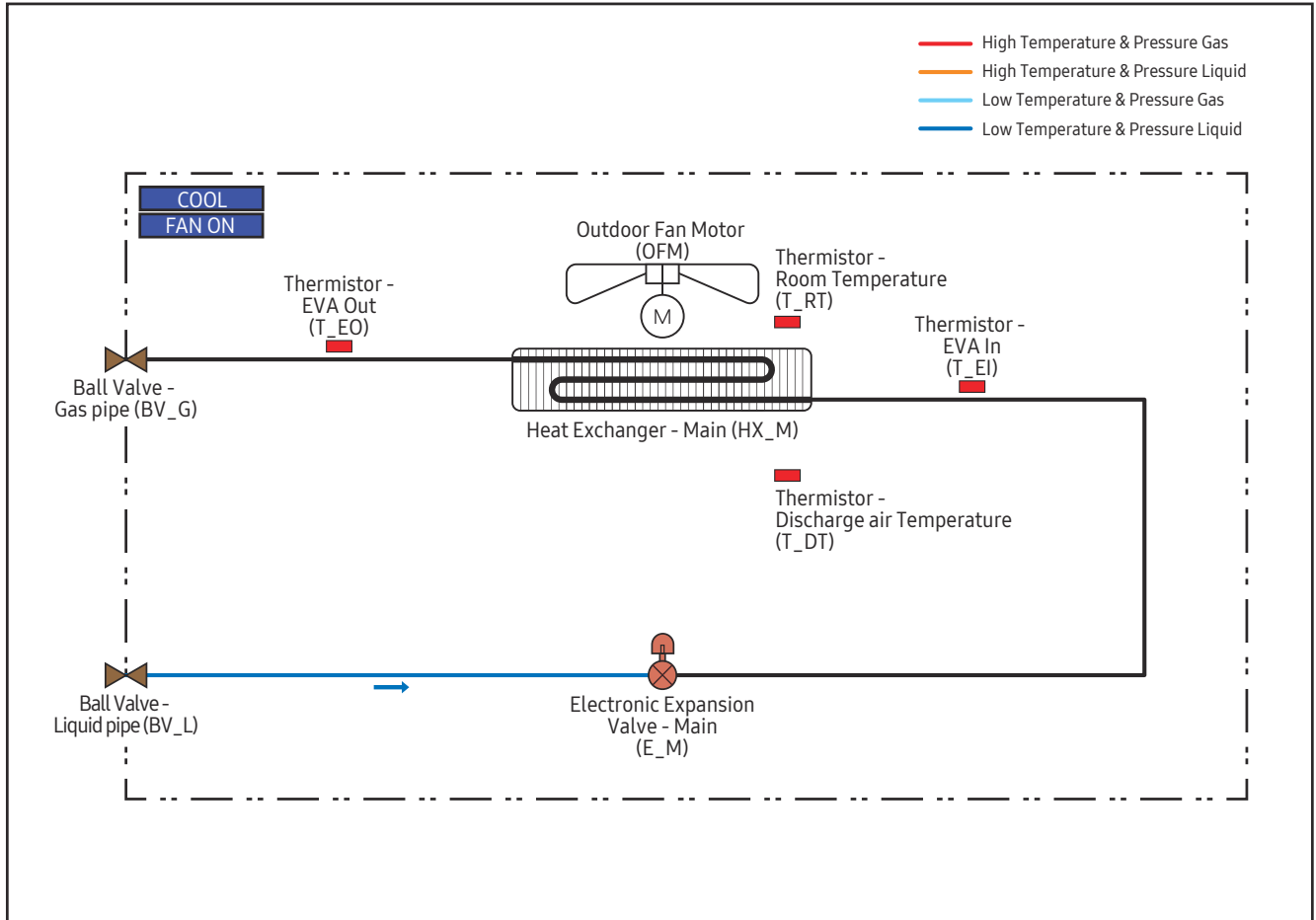

5. UCK (Universal Communication Kit)

5.4. Technical drawings

Wiring Drawings

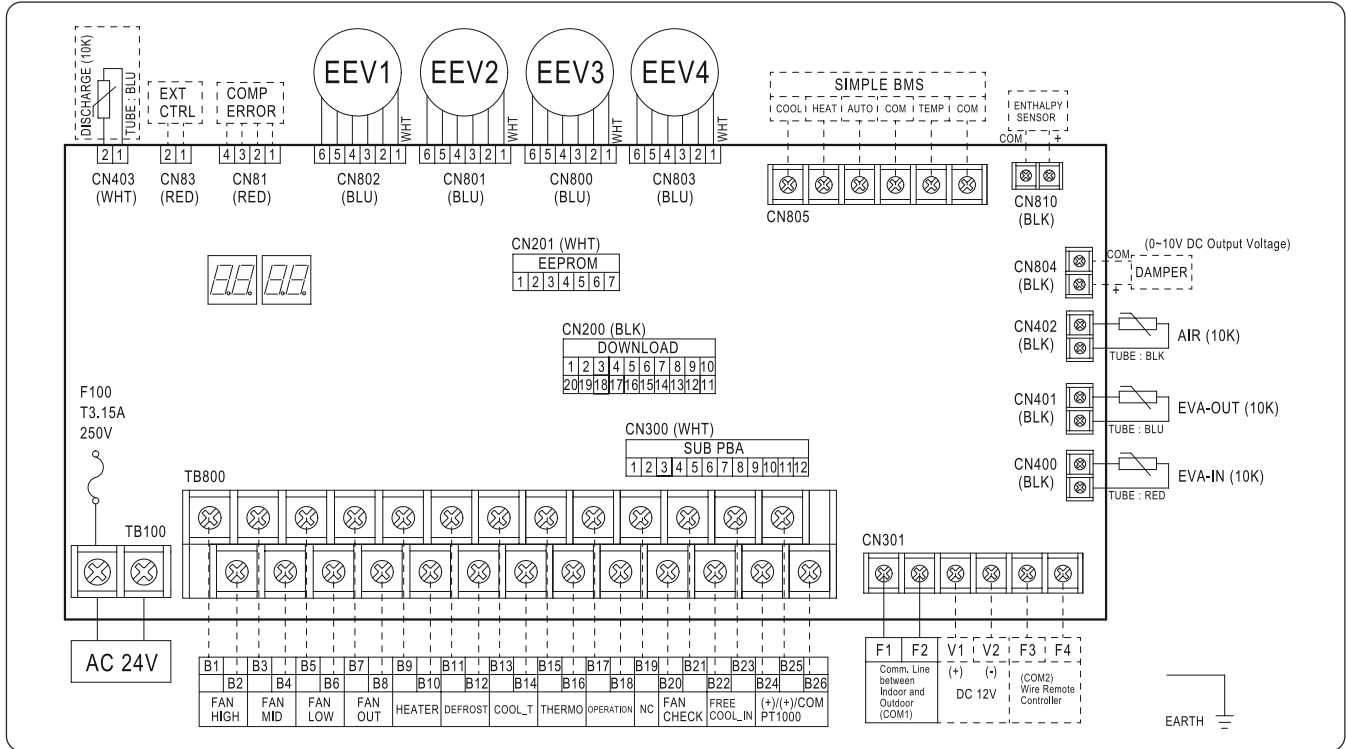

EEV	Electric expansion valve	FAN MID	FAN Output(Step Mid ON)	NC	NO CONNECTION
AIR (10K)	Thermistor ()	FAN LOW	FAN-Output(Step Low ON)	FAN CHECK	Checking fan operation status of input signal
EVA-OUT (10K)	Thermistor (EVA.-OUT_10K)	FAN OUT	FAN-Output(ON/OFF)	FREE COOL_IN	Blowing wind from outside(Input)
EVA-IN (10K)	Thermistor (EVA.-IN_10K)	HEATER	Heater-Output(ON/OFF)	PT1000	PT1000Ω sensor(Input)
DISCHARGE (10K)	Thermistor (Discharge_10K)	DEFROST	Defrost-Output(ON/OFF)	TB100	Terminal Block100(Power)
EXT CTRL	EXTERNAL CONTROL	COOL_T	Coolling Thermo-Output(ON/OFF)	TB800	Terminal Block800(control/Dry Contact)
COMPERROR	Error check output	THERMO	Thermo-Output(ON/OFF)	F100	Fuse
FAN HIGH	FAN-Output (Step High ON)	OPERATION	O(ON/OFF)		

NOTE

- This wiring diagram applies only to Universal Comm. Kit
- Colors BLK: black, RED: red, BLU: blue, WHT: white, YEL: yellow, BRN: brown, SKY: skyblue , ORG: orange, GRN: green
- When operating, don't short circuit the protection device (High Pressure switch)
- Protective earth(screw), : connector, : The wire quantity

5. UCK (Universal Communication Kit)

5.5. Installation

Structure diagram of an Universal Comm. Kit

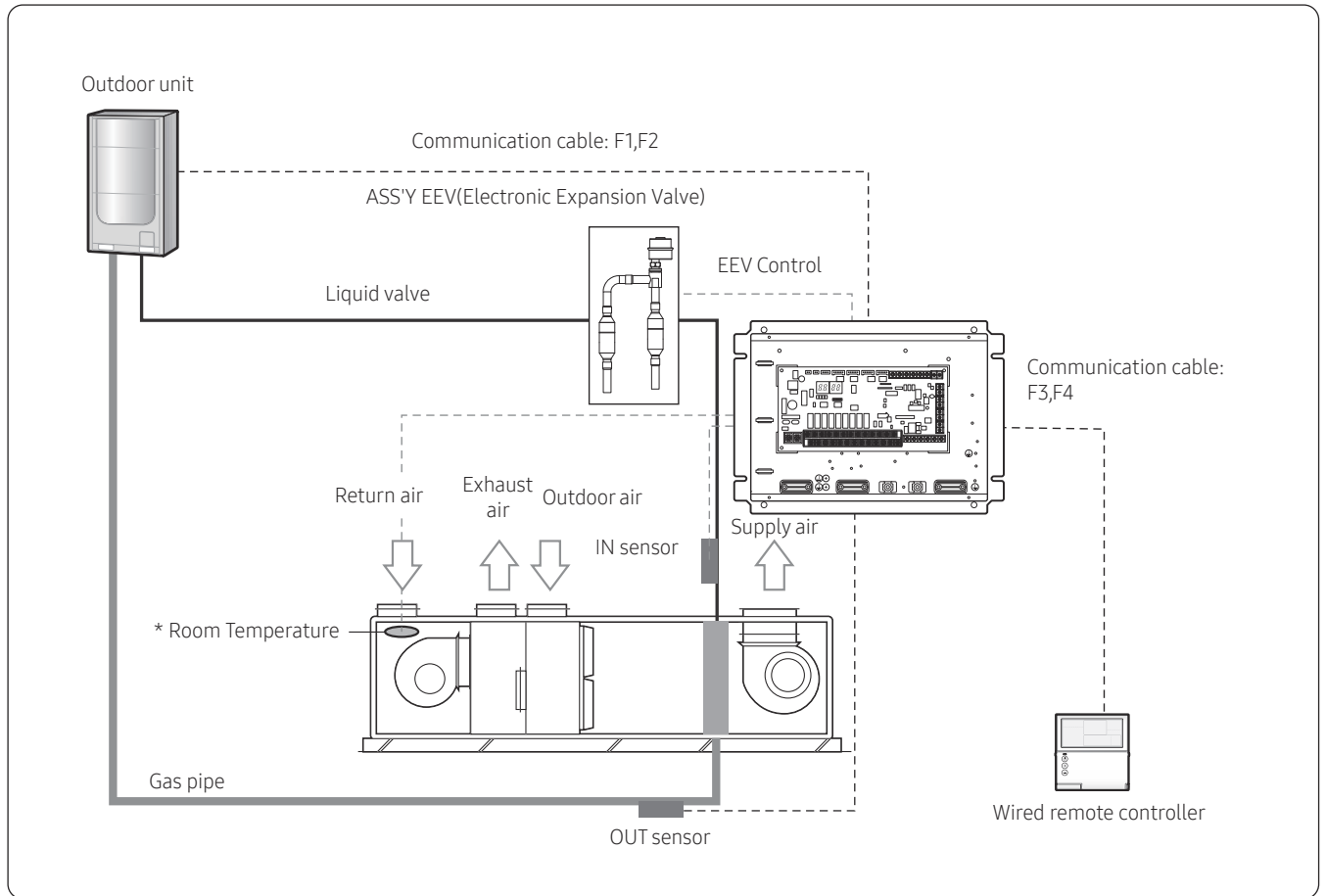

5. UCK (Universal Communication Kit)

5.5. Installation

10.5. Installation

PBA

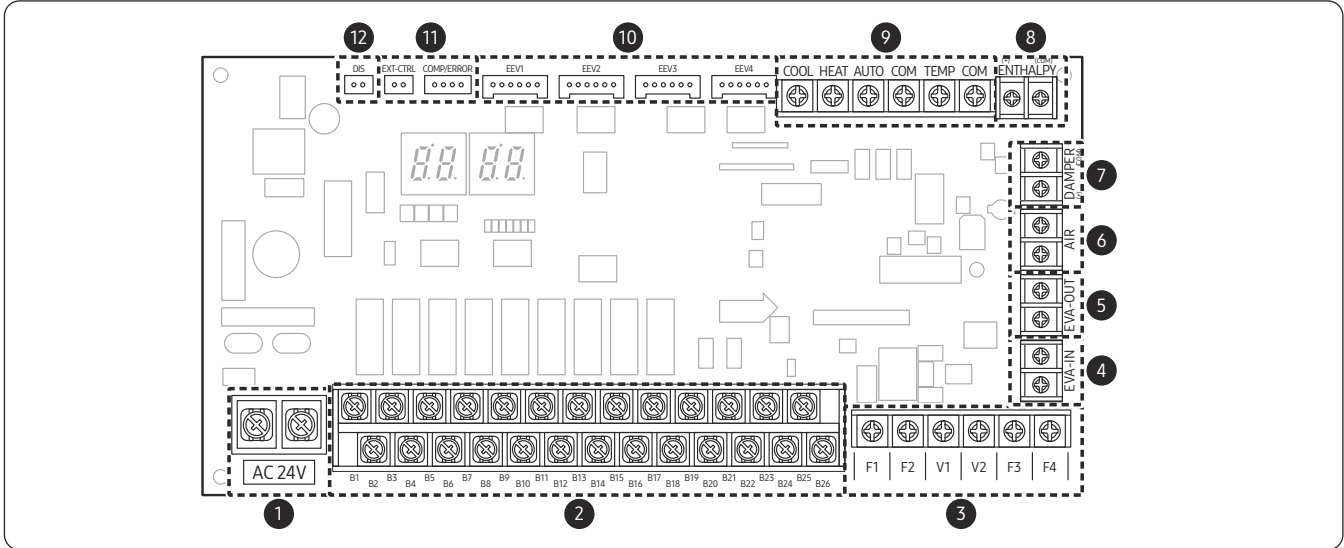

No.	CONNECTOR	SIGNAL	FUNCTION	CONTACT SHORT	CONTACT OPEN	*SCREW	
1	TB100	-	AC24V/60Hz	-	-	M4	
2	TB800	B1	*DRY CONTACT	FAN HIGH	FAN STEP HIGH ON	FAN OFF	M3.5
		B2	*DRY CONTACT	FAN MID	FAN STEP MID ON	FAN OFF	M3.5
		B3	*DRY CONTACT	FAN LOW	FAN STEP LOW ON	FAN OFF	M3.5
		B4	*DRY CONTACT	FAN OUT	FAN ON	FAN OFF	M3.5
		B5	*DRY CONTACT	HEATER	HEATER ON	HEATER OFF	M3.5
		B6	*DRY CONTACT	DEFROST	DEFROST ON	DEFROST OFF	M3.5
		B7	*DRY CONTACT	COOL_T	COOL THERMO ON	COOL THERMO OFF	M3.5
		B8	*DRY CONTACT	THERMO	THERMO ON	THERMO OFF	M3.5
		B9	*DRY CONTACT	OPERATION	OPERATION ON	OPERATION OFF	M3.5
		B10	-	-	-	-	-
		B11	ZERO Voltage CONTACT	FAN CHECK	FAN CHECK ON	FAN CHECK OFF	M3.5
		B12	ZERO Voltage CONTACT	FREE COOL_IN	FREE COOL ON	FREE COOL OFF	M3.5
		B13	INPUT	PT1000	-	-	M3.5
		B14	INPUT				
		B15	COM				

5. UCK (Universal Communication Kit)

5.5. Installation

No.	CONNECTOR	SIGNAL	FUNCTION	CONTACT SHORT	CONTACT OPEN	*SCREW	
3	CN301	F1	-	IN-OUT COMMUNICATION	-	M3.5	
		F2	-				
		F3	DC	DC 12V	-		-
		F4					
		F5	-	WIRED REMOTE COMMUNICATION	-		-
		F6	-				
4	CN400	-	EVA IN SENSOR	-	-	M3	
5	CN401	-	EVA OUT SENSOR	-	-	M3	
6	CN402	-	AIR SENSOR	-	-	M3	
7	CN804	(+)	LEVEL OUT	DAMPER ALNALOG LEVEL	-	-	M3
		COM	COM	-			
8	CN810	(+)	LEVEL IN	ENTHALPY IN	-	-	M3
		COM	COM	-			
9	CN305	COOL	ZERO Voltage CONTACT	SIMPLE BMS MODE IN	-	-	M3.5
		HEAT					
		AUTO					
		COM					
		TEMP	LEVEL IN	SIMPLE BMS TEMP IN	-	-	
		COM	-				
10	CN800~803	-	EEV	-	-		
11	CN81,CN83	-	EXTERNAL CONTROL	-	-		
12	CN403	-	DISCHARGE SENSOR	-	-		

* Use the rated current capacity for the dry contact within AC 250 V/1 A.

* Use the ring terminal that fits the screw.

6. Drain Pumps

6.1. Feature

Drain Pump for Indoor Unit

Drip-free operation

The check valve on the drain pump prevents drained water from flowing backward into the drain pan. This minimizes the drain pan's water level, eliminating the worry and hassle of water stagnation or overflowing drain water dripping into the interior.

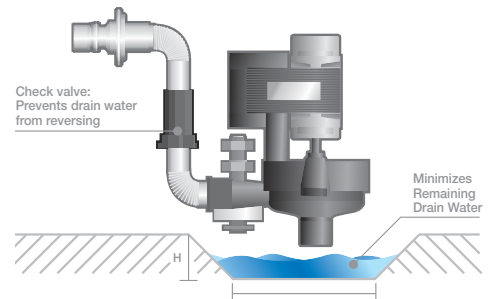

Simple, smart drainage structure

With 750 mm of discharge head, users can install the drain themselves, saving them time and costs.

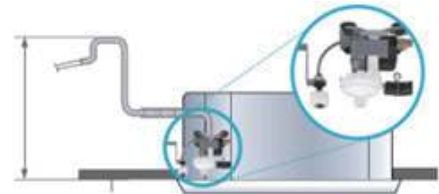

Advanced drain hose

Samsung's Cassette type system air conditioner uses an advanced drain hose, which is recognized in Europe for its easy installation and leak prevention.



Simple drain pump installation

The new drain pump in the Slim Duct unit can be installed from the side by simply removing the right side panel. Users no longer need to disassemble the top cover to install, check or repair the drain pump for maximum convenience.

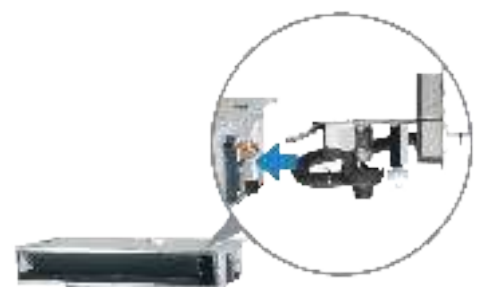

6. Drain Pumps

6.1. Feature

Plug-and-connect drainage

The optional Plug and Connect External Type drain pump takes the hassle out of draining the unit. Simply plug it in and connect it, and with the single drain pump, maintaining all the building's Duct S units is easier than ever.



6.2. Line-up

Model	Application Product	Mounting Type	Remark
ADP-M075SGC	MA-0,1	Internal Type	
ADP-M075SGC1	MA-2	Internal Type	
MDP-M075SGK1	MA-0,1	Internal Type	
MDP-M075SGK2	MA-2	Internal Type	
MDP-M075SGU1	MA-0,1	Internal Type	
MDP-M075SGU2	MA-2	Internal Type	
MDP-M075SGU3	MA-S	Internal Type	
ADP-M075SEC0	MA-S	Internal Type	
ADP-N047SNK1	HSP(MA2)	Internal Type	
MDP-N047SNC1	HSP(MA2)	Internal Type	
MDP-E075SEC3	SLIM1,2,3	Internal Type	
MDP-E075SEE3	SLIM1,2,3	Internal Type	
ADP-E075SEK3	SLIM1,2,3	Internal Type	
MDP-E075SEC4A	SLIM DUCT HOME	Internal Type	
MDP-N047SNC1D	BIG DUCT	Internal Type	
MDP-M075SGU2D	MA2 DUCT	Internal Type	
MDP-M075SGU1D	MA1 DUCT	Internal Type	
MDP-M075SGU3D	MAS DUCT	Internal Type	
MDP-E075SEE3D	SLIM DUCT	Internal Type	
ADP-N047SNK1D	BIG DUCT	Internal Type	
MDP-M075SGK2D	MA2 DUCT	Internal Type	
MDP-M075SGK1D	MA1 DUCT	Internal Type	
ADP-E075SEK3D	SLIM DUCT	Internal Type	
MDP-G075SP	GLOBAL DUCT	External Type	
MDP-G075SQ	GLOBAL DUCT	Internal Type	

6. Drain Pumps

6.3. Spec Sheet

Model		ADP-M075SGC	ADP-M075SGC1	MDP-M075SGK1	MDP-M075SGK2	MDP-M075SGU1
Rated Voltage	V, Hz	AC220~240V – 50/60Hz	AC220~240V – 50/60Hz	AC220~240V – 50/60Hz	DC 12V	AC220~240V – 50/60Hz
Current	mA	114/92 mA	114/92 mA	114/92 mA	Less than 400mA	114/92 mA
		(AC230V-50/60)Max. (on Drain)	(AC230V-50/60)Max. (on Drain)	(AC230V-50/60)Max. (on Drain)	(1200mm Head) Max. empty operating	(AC230V-50/60)Max. (on Drain)
Input	W	12/10.8	12/10.8	12/10.8	Less than 4.0W	12/10.8
		(AC230V-50/60)Max. (on Drain)	(AC230V-50/60)Max. (on Drain)	(AC230V-50/60)Max. (on Drain)	(1200mm Head) Max. empty operating	(AC230V-50/60)Max. (on Drain)
Insulation Class	-	Class “E”	Class “E”	Class “E”	Class “E”	Class “E”
Fluide Temperature	°C	0~40°C (32~104°F)	0~40°C (32~104°F)	0~40°C (32~104°F)	0~45°C (32~113°F)	0~40°C (32~104°F)
		(But no frozen water)	(But no frozen water)	(But no frozen water)	(But no frozen water)	(But no frozen water)
Operating Ambient Temperature	°C	-10~45°C (14~113°F)	-10~45°C (14~113°F)	-10~45°C (14~113°F)	0~45°C (32~113°F)	-10~45°C (14~113°F)
Discharge Fluid Volume	cm ³ / min(1)	Min. 400cm ³ /min (0.0142ft ³ /min)	Min. 400cm ³ /min (0.0142ft ³ /min)	Min. 400cm ³ /min (0.0142ft ³ /min)	Min. 400cm ³ /min (0.0142ft ³ /min)	Min. 400cm ³ /min (0.0142ft ³ /min)
Noise	dB(A)(2)	Max. 40dB(A)	Max. 40dB(A)	Max. 40dB(A)	Max. 40dB(A)	Max. 40dB(A)

Model		MDP-M075SGU2	MDP-M075SGU3	ADP-M075SEC0	ADP-N047SNK1	MDP-N047SNC1
Rated Voltage	V, Hz	AC220~240V – 50/60Hz	AC220~240V – 50/60Hz	AC220~240V – 50/60Hz	AC220~240V – 50/60Hz	AC220~240V – 50/60Hz
Current	mA	114/92 mA	114/92 mA	114/92 mA	114/92 mA	114/92 mA
		(AC230V-50/60)Max. (on Drain)	(AC230V-50/60)Max. (on Drain)	(AC230V-50/60)Max. (on Drain)	(AC230V-50/60)Max. (on Drain)	(AC230V-50/60)Max. (on Drain)
Input	W	12/10.8	12/10.8	12/10.8	12/10.8	12/10.8
		(AC230V-50/60)Max. (on Drain)	(AC230V-50/60)Max. (on Drain)	(AC230V-50/60)Max. (on Drain)	(AC230V-50/60)Max. (on Drain)	(AC230V-50/60)Max. (on Drain)
Insulation Class	-	Class “E”	Class “E”	Class “E”	Class “E”	Class “E”
Fluide Temperature	°C	0~40°C (32~104°F)	0~40°C (32~104°F)	0~40°C (32~104°F)	0~40°C (32~104°F)	0~40°C (32~104°F)
		(But no frozen water)	(But no frozen water)	(But no frozen water)	(But no frozen water)	(But no frozen water)
Operating Ambient Temperature	°C	-10~45 °C (14~113°F)	-10~45 °C (14~113°F)	-10~45 °C (14~113°F)	-10~45 °C (14~113°F)	-10~45 °C (14~113°F)
Discharge Fluid Volume	cm ³ / min(1)	Min. 400cm ³ /min (0.0142ft ³ /min)	Min. 400cm ³ /min (0.0142ft ³ /min)	Min. 400cm ³ /min (0.0142ft ³ /min)	Min. 400cm ³ /min (0.0142ft ³ /min)	Min. 400cm ³ /min (0.0142ft ³ /min)
Noise	dB(A)(2)	Max. 40dB(A)	Max. 40dB(A)	Max. 40dB(A)	Max. 40dB(A)	Max. 40dB(A)

Model		MDP-E075SEC3	MDP-E075SEE3	ADP-E075SEK3	MDP-E075SEC4A	MDP-N047SNC1D
Rated Voltage	V, Hz	AC220~240V – 50/60Hz	AC220~240V – 50/60Hz	AC220~240V – 50/60Hz	AC220~240V – 50/60Hz	DC 12V
Current	mA	114/92 mA	114/92 mA	114/92 mA	114/92 mA	Less than 400mA
		(AC230V-50/60)Max. (on Drain)	(AC230V-50/60)Max. (on Drain)	(AC230V-50/60)Max. (on Drain)	(AC230V-50/60)Max. (on Drain)	(1200mm Head) Max. empty operating
Input	W	12/10.8	12/10.8	12/10.8	12/10.8	Less than 4.0W
		(AC230V-50/60)Max. (on Drain)	(AC230V-50/60)Max. (on Drain)	(AC230V-50/60)Max. (on Drain)	(AC230V-50/60)Max. (on Drain)	(1200mm Head) Max. empty operating
Insulation Class	-	Class “E”	Class “E”	Class “E”	Class “E”	Class “E”
Fluide Temperature	°C	0~40 °C (32~104°F)	0~40 °C (32~104°F)	0~40 °C (32~104°F)	0~40 °C (32~104°F)	0~45 °C (32~113°F)
		(But no frozen water)	(But no frozen water)	(But no frozen water)	(But no frozen water)	(But no frozen water)
Operating Ambient Temperature	°C	-10~45 °C (14~113°F)	-10~45 °C (14~113°F)	-10~45 °C (14~113°F)	-10~45 °C (14~113°F)	0~45 °C (32~113°F)
Discharge Fluid Volume	cm ³ / min(1)	Min. 400cm ³ /min (0.0142ft ³ /min)	Min. 400cm ³ /min (0.0142ft ³ /min)	Min. 400cm ³ /min (0.0142ft ³ /min)	Min. 400cm ³ /min (0.0142ft ³ /min)	Min. 400cm ³ /min (0.0142ft ³ /min)
Noise	dB(A)(2)	Max. 40dB(A)	Max. 40dB(A)	Max. 40dB(A)	Max. 40dB(A)	Max. 40dB(A)

- 1 Discharge fluid volume : 1200mm lift 10mm water level rated voltage
- 2 Noise : AC Motor - 1meter distance from drive motor head empty operating, 1200mm lift 10mm water level rated voltage
DC Motor - 1meter distance from drive motor head (300mm Head, 5mm water level, rated voltage)

6. Drain Pumps

6.3. Spec Sheet

Model		MDP-M075SGU2D	MDP-M075SGU1D	MDP-M075SGU3D	MDP-E075SEE3D	ADP-N047SNK1D
Rated Voltage	V, Hz	DC 12V	DC 12V	DC 12V	DC 12V	DC 12V
Current	mA	Less than 400mA	Less than 400mA	Less than 400mA	Less than 400mA	Less than 400mA
		(1200mm Head) Max. empty operating	(1200mm Head) Max. empty operating	(1200mm Head) Max. empty operating	(1200mm Head) Max. empty operating	(1200mm Head) Max. empty operating
Input	W	Less than 4.0W	Less than 4.0W	Less than 4.0W	Less than 4.0W	Less than 4.0W
		(1200mm Head) Max. empty operating	(1200mm Head) Max. empty operating	(1200mm Head) Max. empty operating	(1200mm Head) Max. empty operating	(1200mm Head) Max. empty operating
Insulation Class	-	Class "E"	Class "E"	Class "E"	Class "E"	Class "E"
Fluide Temperature	°C	0~45 °C (32~113°F)	0~45 °C (32~113°F)	0~45 °C (32~113°F)	0~45 °C (32~113°F)	0~45 °C (32~113°F)
		(But no frozen water)	(But no frozen water)	(But no frozen water)	(But no frozen water)	(But no frozen water)
Operating Ambient Temperature	°C	0~45 °C (32~113°F)	0~45 °C (32~113°F)	0~45 °C (32~113°F)	0~45 °C (32~113°F)	0~45 °C (32~113°F)
Discharge Fluid Volume	cm ³ / min(1)	Min. 400cm ³ /min (0.0142ft ³ /min)	Min. 400cm ³ /min (0.0142ft ³ /min)	Min. 400cm ³ /min (0.0142ft ³ /min)	Min. 400cm ³ /min (0.0142ft ³ /min)	Min. 400cm ³ /min (0.0142ft ³ /min)
Noise	dB(A)(2)	Max. 40dB(A)	Max. 40dB(A)	Max. 40dB(A)	Max. 40dB(A)	Max. 40dB(A)

Model		MDP-M075SGK2D	MDP-M075SGK1D	ADP-E075SEK3D	MDP-G075SP	MDP-G075SQ
Rated Voltage	V, Hz	DC 12V	DC 12V	DC 12V	DC 12V	DC 12V
Current	mA	Less than 400mA	Less than 400mA	Less than 400mA	Less than 400mA	Less than 400mA
		(1200mm Head) Max. empty operating	(1200mm Head) Max. empty operating	(1200mm Head) Max. empty operating	(1200mm Head) Max. empty operating	(1200mm Head) Max. empty operating
Input	W	Less than 4.0W	Less than 4.0W	Less than 4.0W	Less than 4.0W	Less than 4.0W
		(1200mm Head) Max. empty operating	(1200mm Head) Max. empty operating	(1200mm Head) Max. empty operating	(1200mm Head) Max. empty operating	(1200mm Head) Max. empty operating
Insulation Class	-	Class "E"	Class "E"	Class "E"	Class "E"	Class "E"
Fluide Temperature	°C	0~45 °C (32~113°F)	0~45 °C (32~113°F)	0~45 °C (32~113°F)	0~45 °C (32~113°F)	0~45 °C (32~113°F)
		(But no frozen water)	(But no frozen water)	(But no frozen water)	(But no frozen water)	(But no frozen water)
Operating Ambient Temperature	°C	0~45 °C (32~113°F)	0~45 °C (32~113°F)	0~45 °C (32~113°F)	0~45 °C (32~113°F)	0~45 °C (32~113°F)
Discharge Fluid Volume	cm ³ / min(1)	Min. 400cm ³ /min (0.0142ft ³ /min)	Min. 400cm ³ /min (0.0142ft ³ /min)	Min. 400cm ³ /min (0.0142ft ³ /min)	Min. 400cm ³ /min (0.0142ft ³ /min)	Min. 400cm ³ /min (0.0142ft ³ /min)
Noise	dB(A)(2)	Max. 40dB(A)	Max. 40dB(A)	Max. 40dB(A)	Max. 40dB(A)	Max. 40dB(A)

- 1 Discharge fluid volume : 1200mm lift 10mm water level rated voltage
- 2 Noise : AC Motor - 1meter distance from drive motor head empty operating, 1200mm lift 10mm water level rated voltage
DC Motor - 1meter distance from drive motor head (300mm Head, 5mm water level, rated voltage)

6. Drain Pumps

6.4. Technical drawings

Dimensional drawings

MDP-E075SEE3

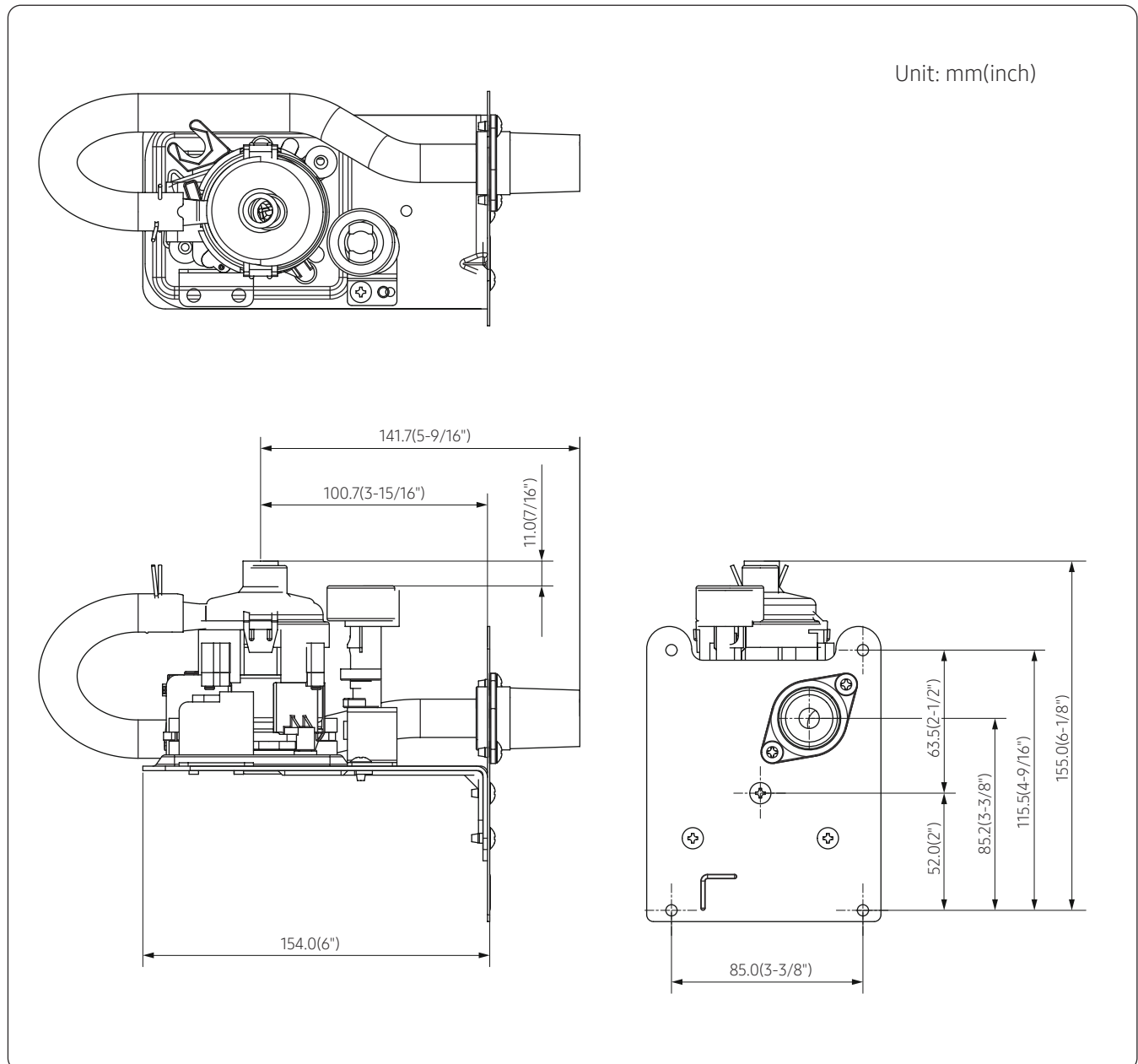

6. Drain Pumps

6.4. Technical drawings

MDP-G075SP

Unit: mm(inch)

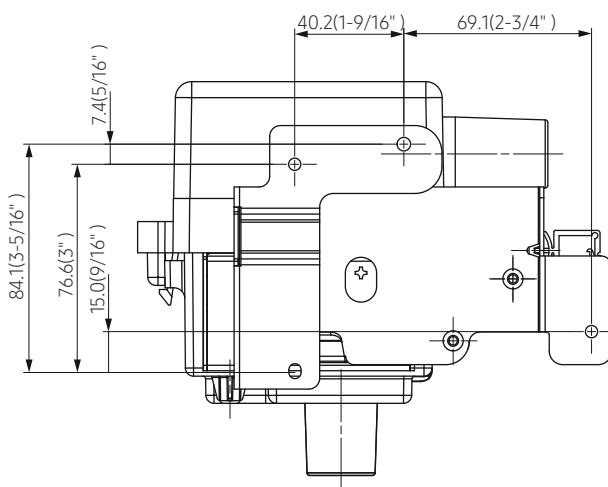
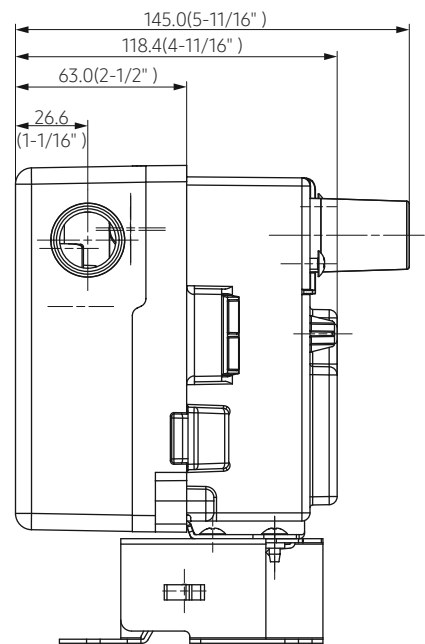
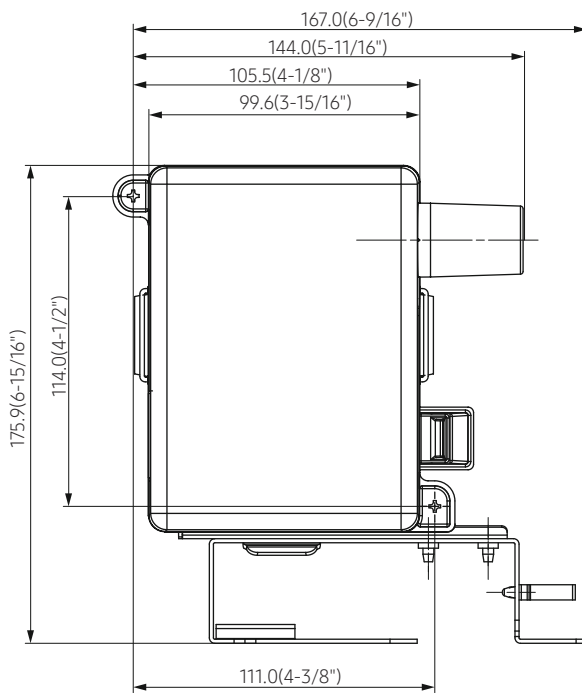

6. Drain Pumps

6.4. Technical drawings

MDP-G075SQ

Unit: mm(inch)

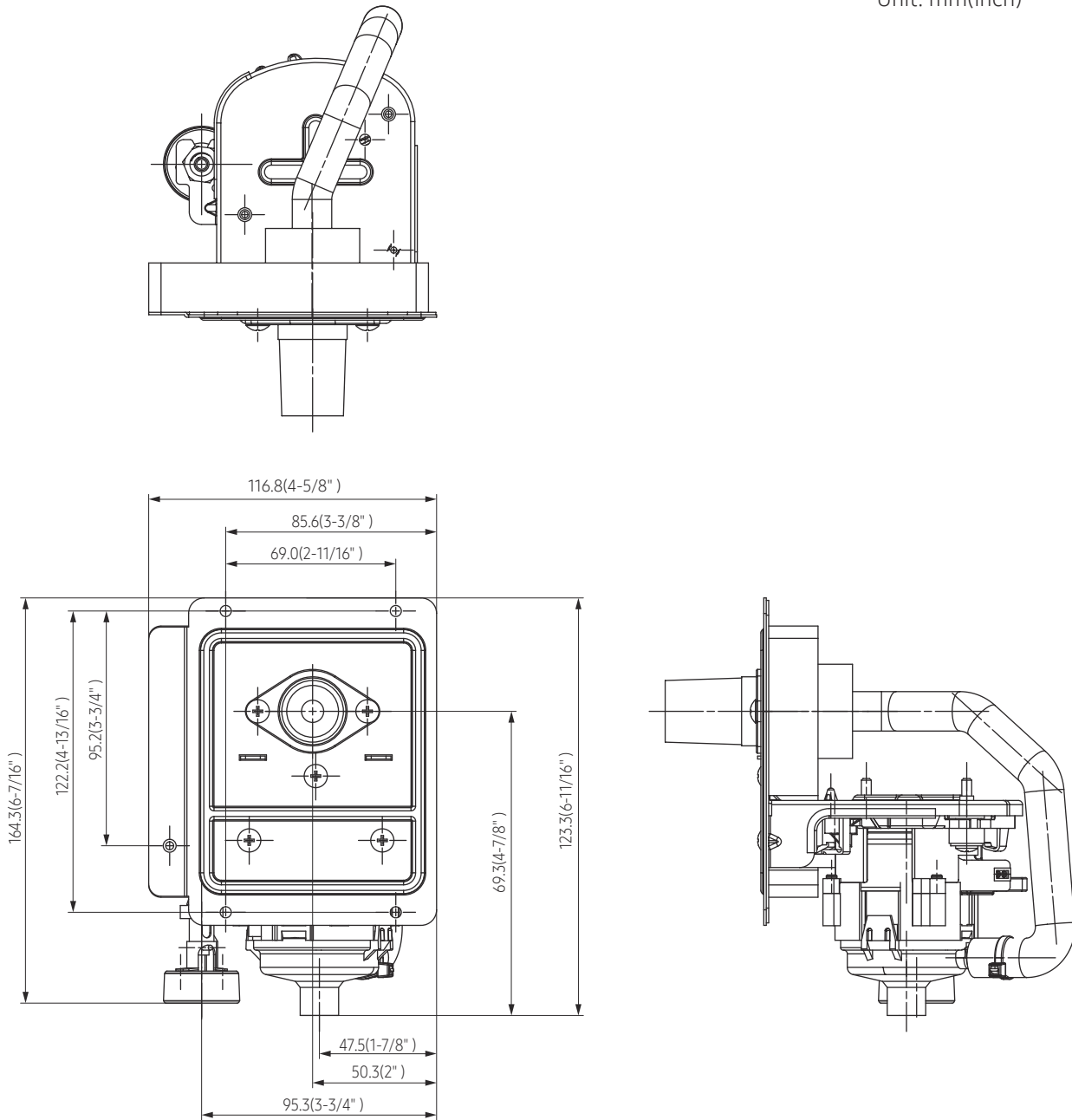

6. Drain Pumps

6.4. Technical drawings

MDP-E075SEC4A

Unit: mm(inch)

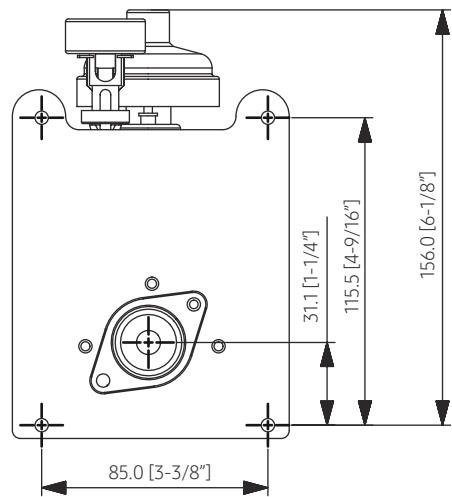
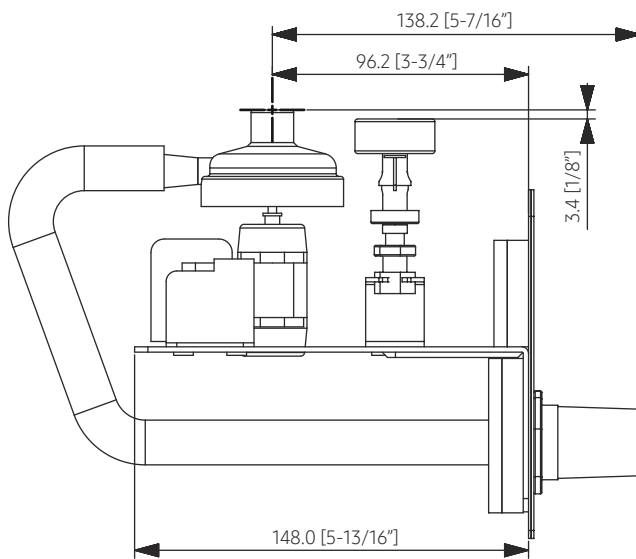
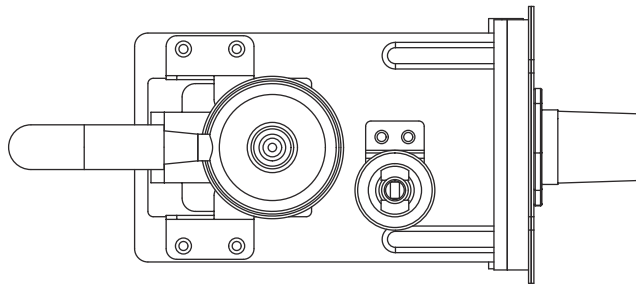

6. Drain Pumps

6.4. Technical drawings

MDP-E075SEE3 (MDP-E075SEE3, MDP-E075SEC3, MDP-E075SEK3)

Unit: mm(inch)

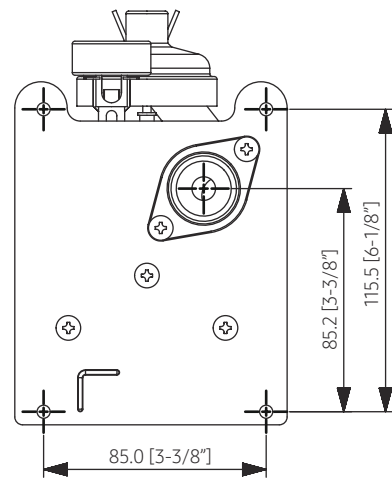
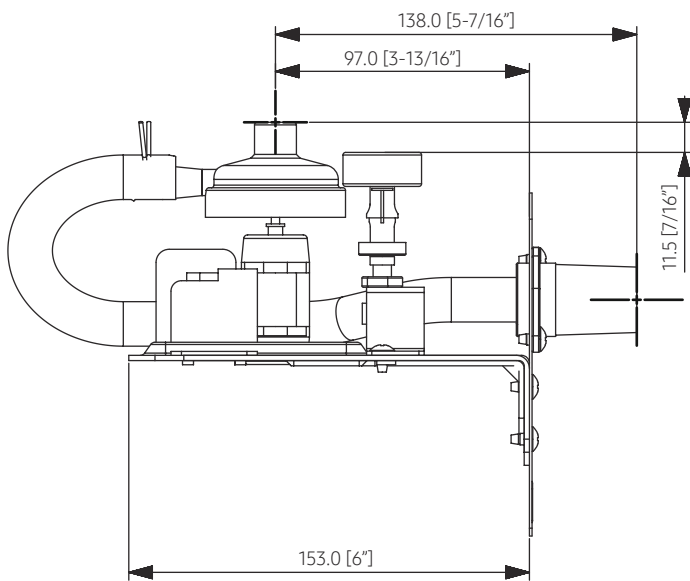
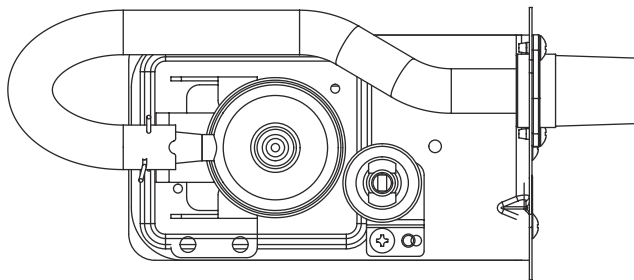

6. Drain Pumps

6.4. Technical drawings

MDP-E075SEE3D (MDP-E075SEE3D, MDP-E075SEK3D)

Unit: mm(inch)

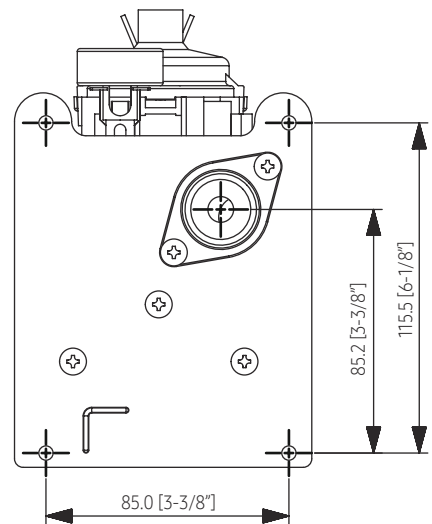
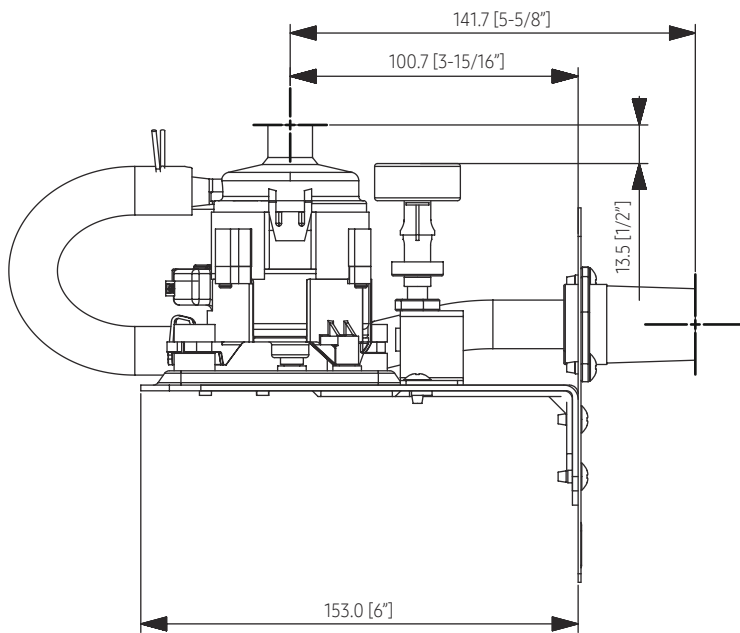
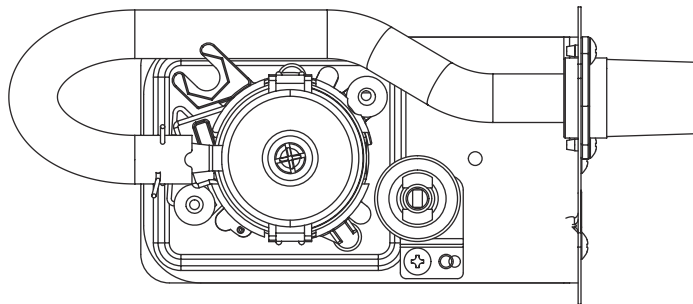

7. Low Ambient Cooling kit (This optional kit is sold only in North America)

7.1. Part Names and Components

Low Ambient Control kit (Assy Control kit)

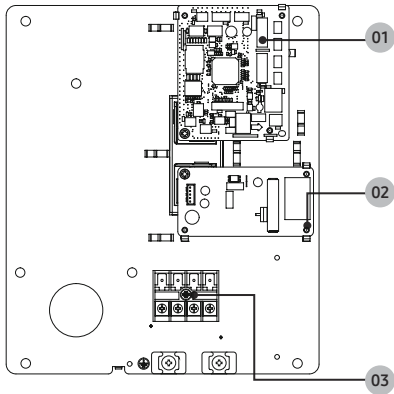

- 01 MAIN PBA
- 02 SMPS PBA
- 03 TERMINAL BLOCK

Components

Name	Body	Communication Cable	Power Cable	
Amount	1	1	1	
Shape				
		*SPEC : 300V/500V H05RN-F 0.75 ²	*SPEC : 300V/500V H05RN-F 0.75 ²	
Name	Cable Tie	Installation Manual	Grounding Screw	Connection Cable
Amount	5	1	1	2
Shape				
				*SPEC : UL1015 AWG#18

7. Low Ambient Cooling kit (This optional kit is sold only in North America)

7.2 Electrical Wiring Diagram

1 Connect the actuator to TRANS.

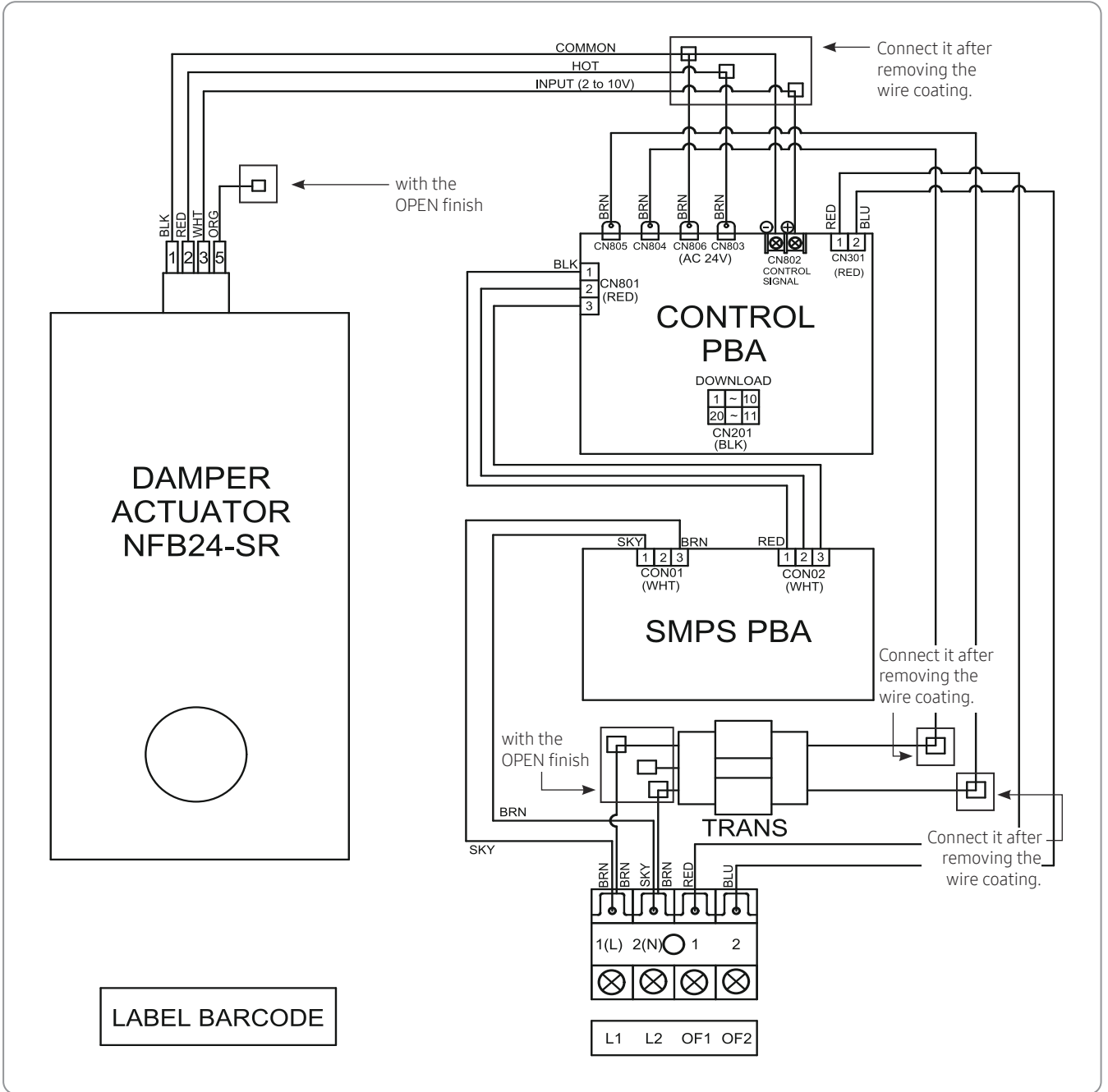

7. Low Ambient Cooling kit (This optional kit is sold only in North America)

7.3 Assembling

1 Assemble the control box and the control kit.

<Control box specification determinants>

- The control kit must be taken into the control box. (Check the fitting holes.)
- The UL certification must be acquired.
- When the louver actuator shaft enters into the box, prevent water penetration. (Use a bushing and such.)
- When assembling the control kit, use the boss with 12 mm or above in size. (The heat transfer distance between the control kit and control box must be 12 mm or above.)

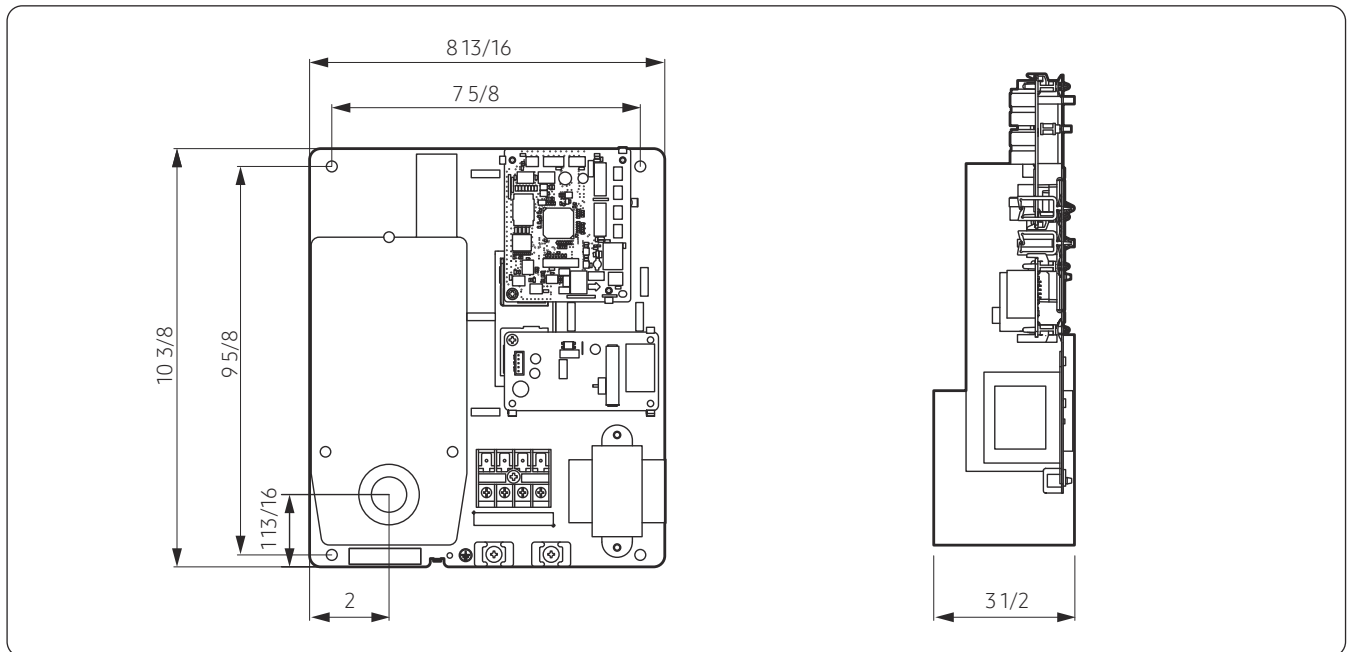
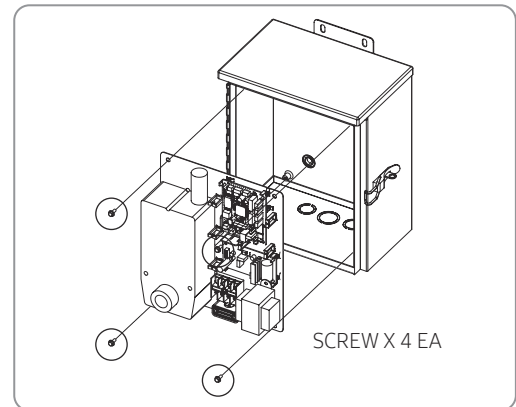

2 Assemble the damper and Assy control box.

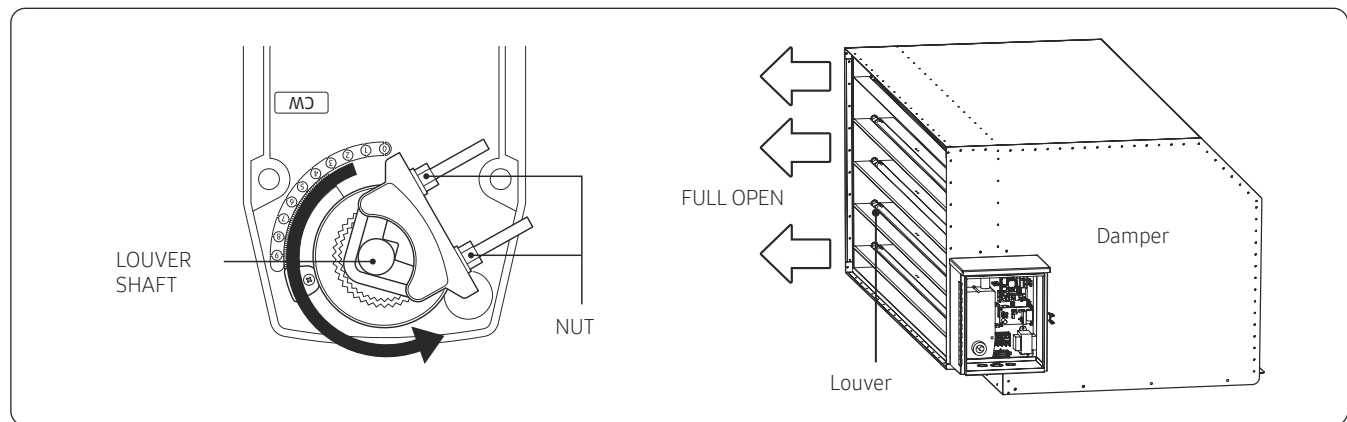

⚠ WARNING

- When assembling the damper and Assy control box, be sure to fix the shaft and actuator (Nut x2) in the louver in fully open state.

7. Low Ambient Cooling kit (This optional kit is sold only in North America)

7.4 Combination unit

Construction of outdoor unit and low ambient cooling kit

Components of Low Ambient Cooling kit for the Outdoor Unit

Model Number	Position Type
LACH-SL	Low Ambient Cooling Hood - Small (chassis) Left
LACH-SR	Low Ambient Cooling Hood - Small (chassis) Right
LACH-R1	Low Ambient Cooling Hood - Rear 1 (Small chassis)
LACH-R2	Low Ambient Cooling Hood - Rear 2 (Large A type chassis)
LACH-SLR	Low Ambient Cooling Hood - Left/Right (Large B type chassis)
LACH-R3	Low Ambient Cooling Hood - Rear 3 (Large B type chassis)
LACH-F1	Low Ambient Cooling Hood - Front 1 (Large A type chassis)
LACKD-1 (= LACH-1)	Low Ambient Cooling kit Damper-1(Small chassis) (Low Ambient Cooling Hood-1 (Small chassis))
LACKD-2 (= LACH-2)	Low Ambient Cooling kit Damper-2 (Large A,B type chassis) (Low Ambient Cooling Hood-2 (Large A,B type chassis))

Required Model Number per chassis	Model Number				
	Left	Right	Back	Front	Top
DVM S Small chassis	LACH-SL	LACH-SR	LACH-R1	-	LACKD-1 (= LACH-1)
DVM Large A type chassis	LACH-SL	LACH-SR	LACH-R2	-	LACKD-2 (= LACH-2)
DVM Large B type chassis	LACH-SLR	LACH-SLR	LACH-R3	LACH-F1	LACKD-2 (= LACH-2)

CAUTION

- When installing the components in the outdoor unit, be careful for screws not to touch the heat exchanger pin.

7. Low Ambient Cooling kit (This optional kit is sold only in North America)

7.5 Dimensions

UNIT : inch

LACH-SR	LACH-SL
<p>Technical drawing of LACH-SR showing front and side views. Dimensions include: top width $23 \frac{11}{16}$, bottom width $21 \frac{5}{16}$, total height $49 \frac{9}{16}$, top offset $8 \frac{1}{8}$, top offset height $6 \frac{15}{16}$, bottom offset height $41 \frac{7}{16}$, and base width 22.</p>	<p>Technical drawing of LACH-SL showing front and side views. Dimensions include: top width $18 \frac{3}{4}$, bottom width $16 \frac{3}{8}$, total height $49 \frac{9}{16}$, top offset height $6 \frac{15}{16}$, bottom offset height $41 \frac{7}{16}$, top offset $8 \frac{1}{8}$, and base width 22.</p>
LACH-R1	LACH-R2
<p>Technical drawing of LACH-R1 showing front and side views. Dimensions include: top width $31 \frac{1}{16}$, bottom width $28 \frac{11}{16}$, total height $49 \frac{9}{16}$, top offset $8 \frac{1}{8}$, top offset height $6 \frac{15}{16}$, bottom offset height $41 \frac{7}{16}$, and base width 22.</p>	<p>Technical drawing of LACH-R2 showing front and side views. Dimensions include: top width $47 \frac{1}{2}$, bottom width $45 \frac{1}{8}$, total height $49 \frac{9}{16}$, top offset height $6 \frac{15}{16}$, bottom offset height $41 \frac{7}{16}$, top offset $8 \frac{1}{8}$, and base width 22.</p>

7. Low Ambient Cooling kit (This optional kit is sold only in North America)

7.5 Dimensions

UNIT : inch

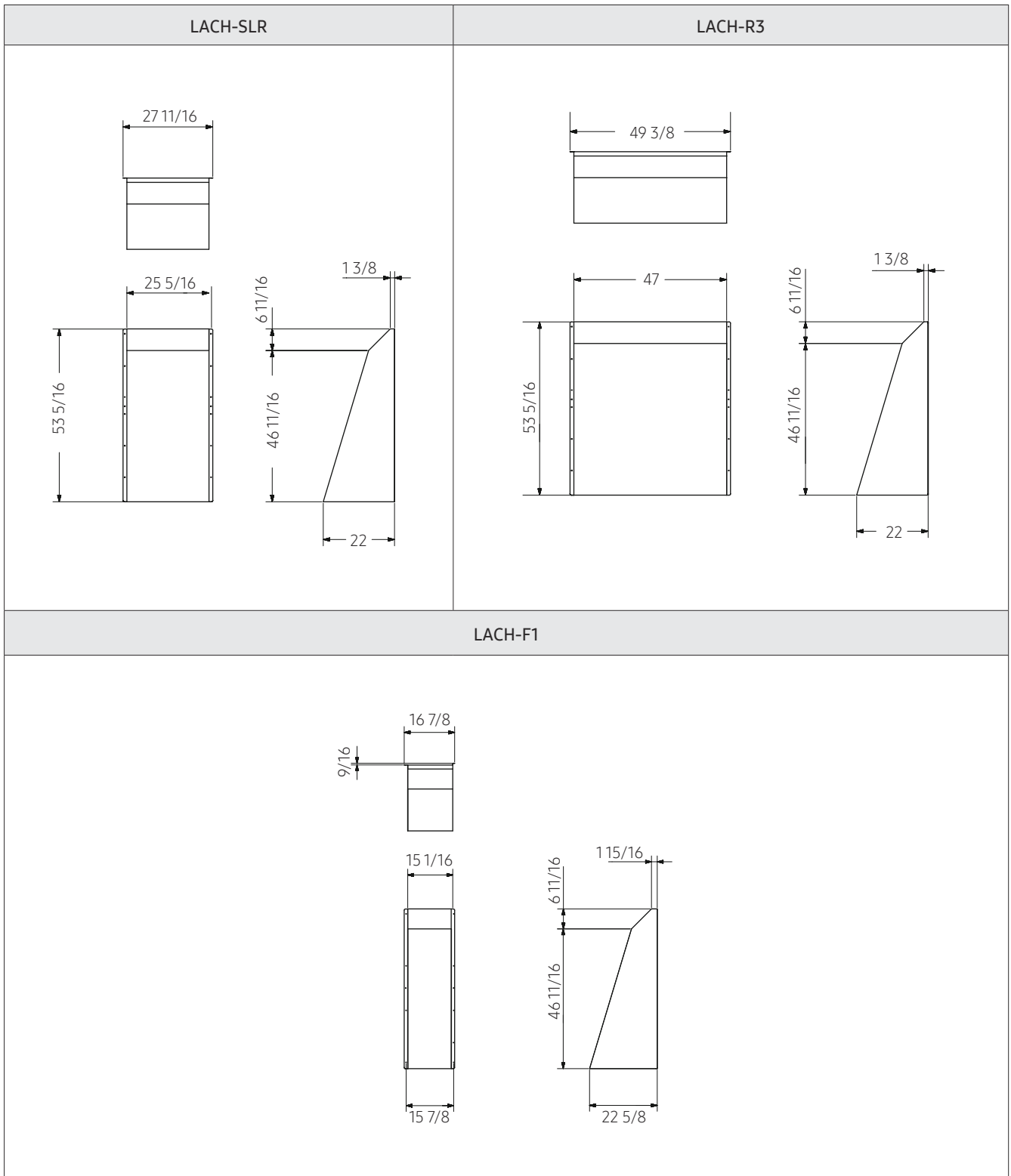

7. Low Ambient Cooling kit (This optional kit is sold only in North America)

7.5 Dimensions

UNIT : inch

Low Ambient Cooling kit Damper-1 (Small chassis)
(Low Ambient Cooling Hood-1 (Small chassis))

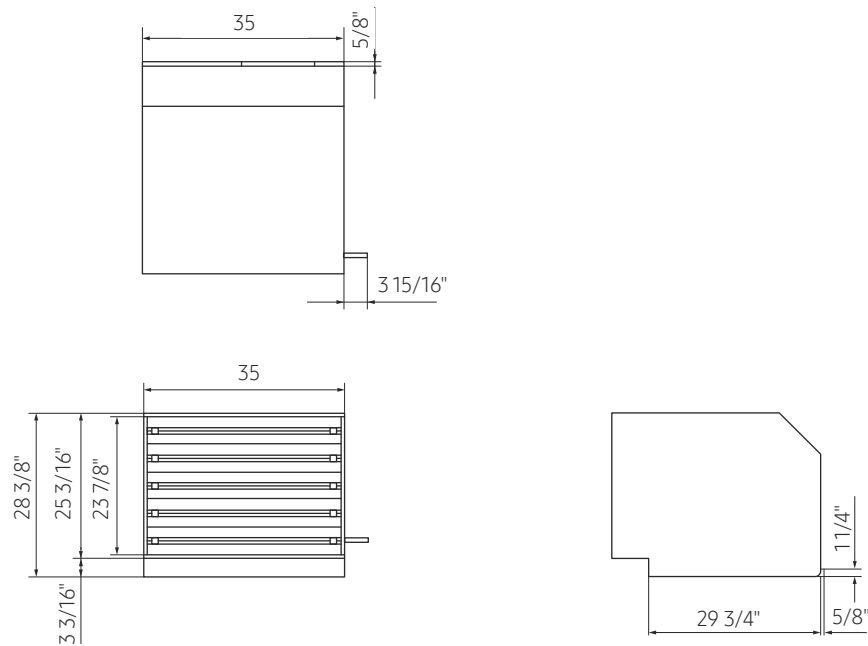

Low Ambient Cooling kit Damper-2 (Large A,B type chassis)
(Low Ambient Cooling Hood-2 (Large A,B type chassis))

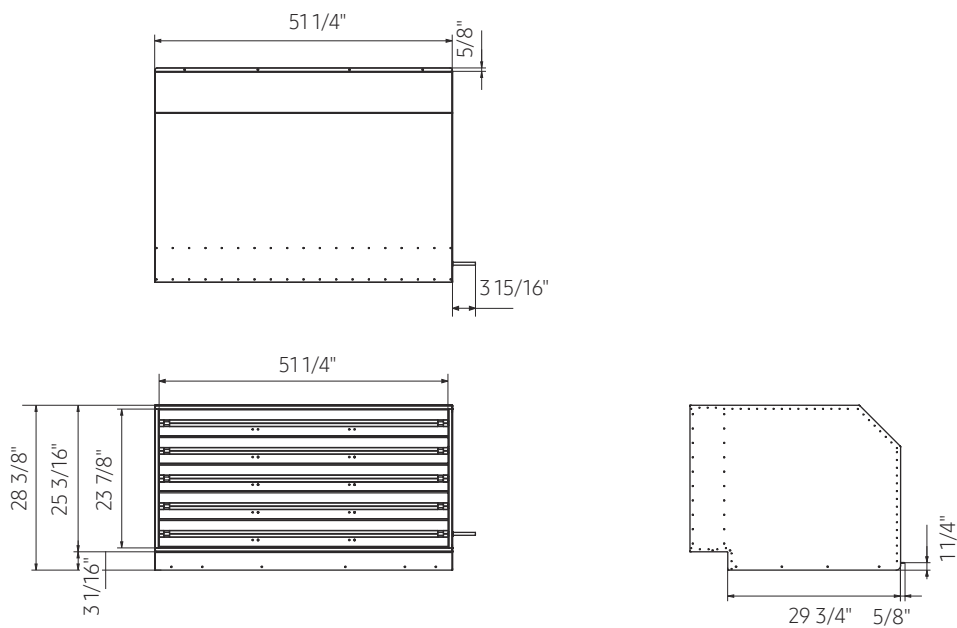

7. Low Ambient Cooling kit (This optional kit is sold only in North America)

7.6 Installation

Installation Environment for Low Ambient Cooling kit

- 1 Keep the height of the frame and foundation 12" or above.

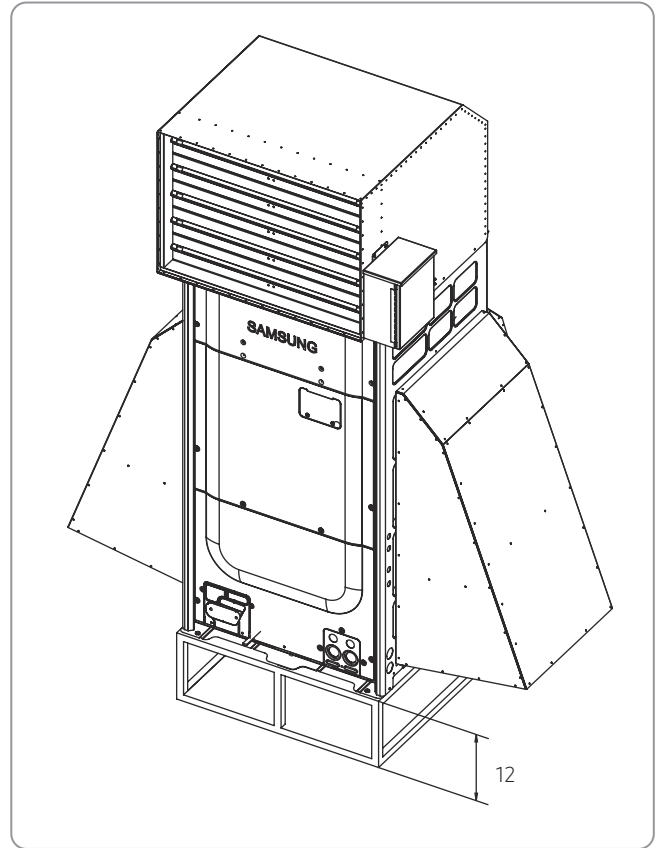

- 2 Remove any obstacles that screen the damper outlet.
- 3 Align the damper outlet with the main wind direction. (In case of head wind, the performance can be lowered.)

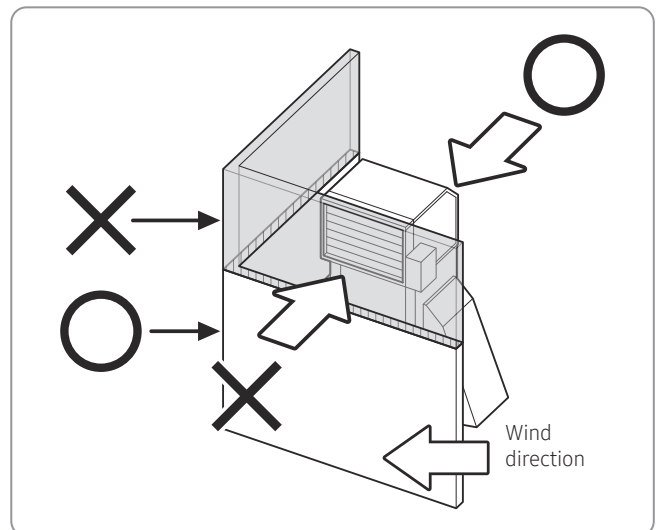

7. Low Ambient Cooling kit (This optional kit is sold only in North America)

7.6 Installation

How to Install the Low Ambient Cooling kit Damper

- 1 In order to install the damper, use the lift or crane. Otherwise, at least 2 people are required for installation.
- 2 Before installation, remove the guard fan from the outdoor unit.
- 3 When connecting the damper to the outdoor unit, **TOP VIEW** fasten screws in all marked places (34 sites).

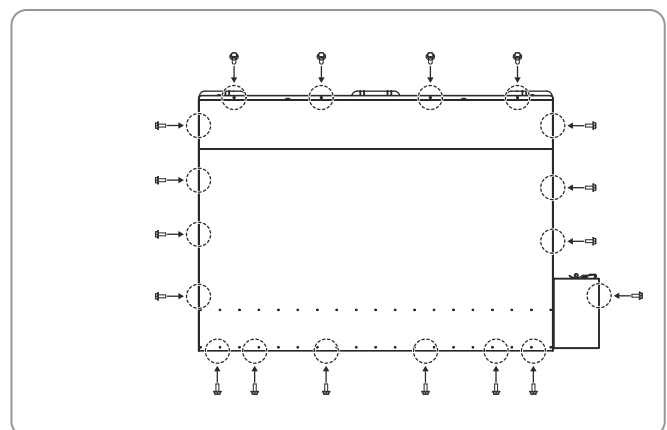
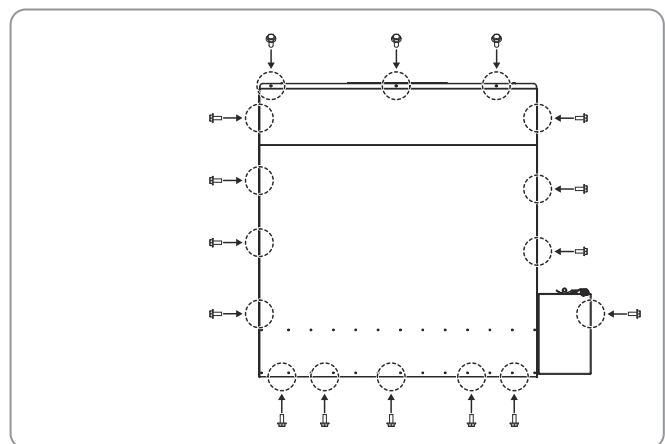

7. Low Ambient Cooling kit (This optional kit is sold only in North America)

7.6 Installation

Connecting the Low Ambient Cooling kit to the Outdoor Unit

Connecting the outdoor unit

Connect the hub PBA to power supplies (L1, L2) and then connect the communication cable through OF1 and OF2.

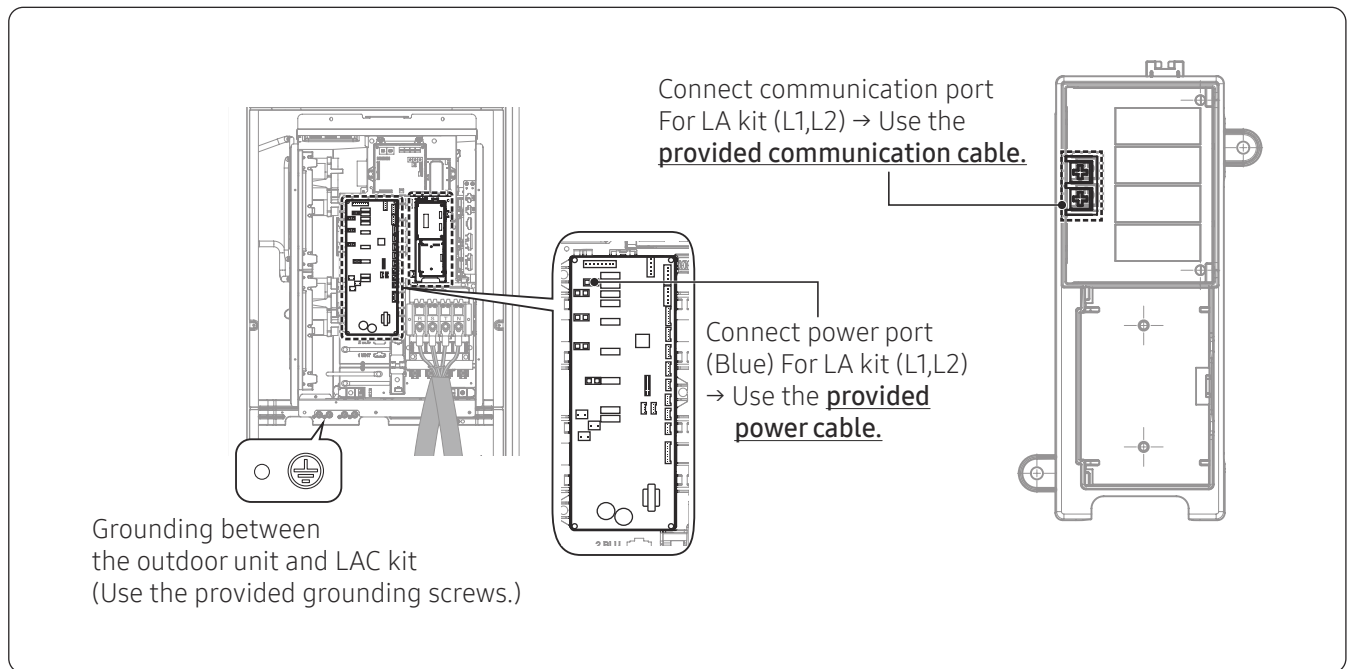

Connecting the kit

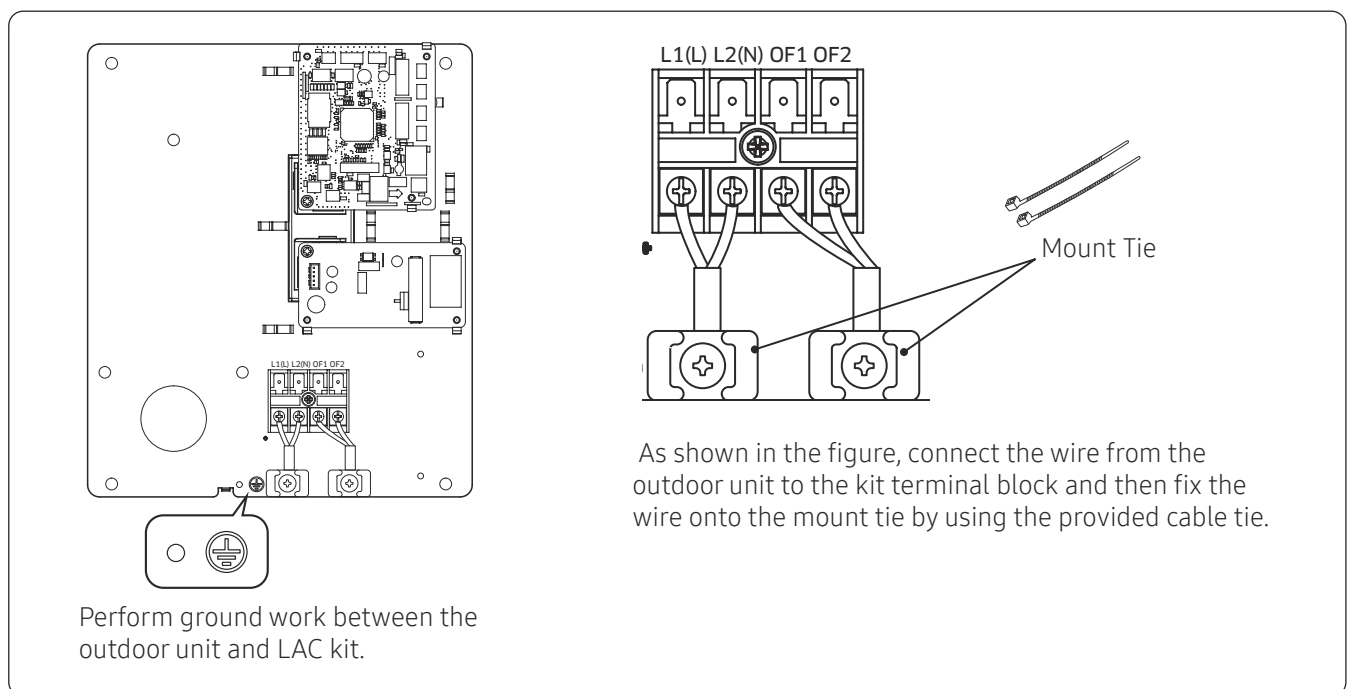

7. Low Ambient Cooling kit (This optional kit is sold only in North America)

7.6 Installation

Extracting the power and communication cables

- Be sure to extract the power and communication cables through the cover (knockout) at the lower right of the front panel or through the knockout hole on the right of the cabinet.
- Extract the communication cable through the outlet (knockout) at the lower right of the side or front panel.
- Install the power and communication cables separately by securing with cable protection conduit.
- Fix the cable protection conduit onto the outdoor knockout tubes by using the CD connector and bushing. At this time, use the insulation bushing.

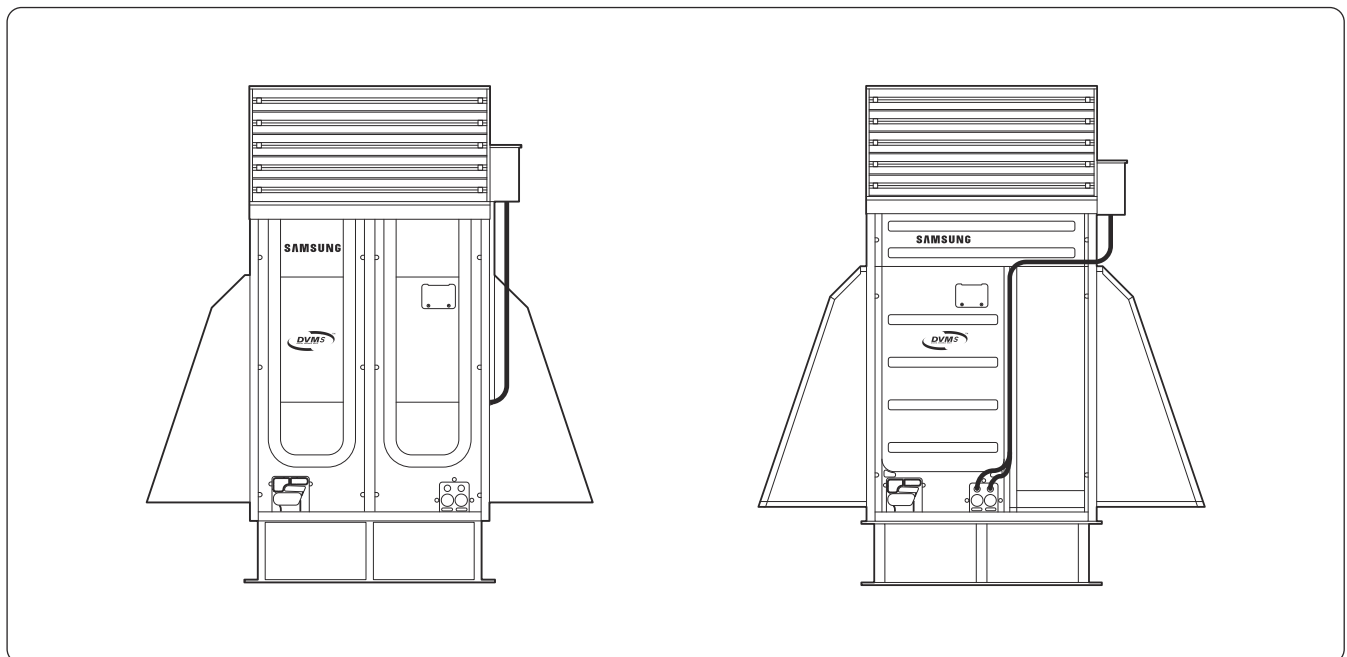

7. Low Ambient Cooling kit (This optional kit is sold only in North America)

7.6 Installation

Configuring the options of the outdoor unit for installation of LAC kit

When installing LAC kit, be sure to enable the LAC kit function for the outdoor unit.

When installing the modules, enable the function on the main outdoor unit.

Configuring key functions of the outdoor unit

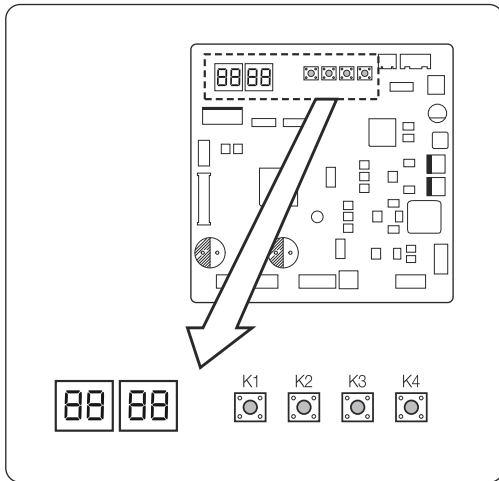

Installation with an aid of tact switch and configuration of options

- Configuring the options

1 Press and hold K2 to enter the setup. (Available in operation stop status)

- The following appears. (In case of compressor cut-off setting, 1 or 2 appears in Seg4.)



- In Seg1 and Seg2, the number of the selected option appears.
- In Seg3 and Seg4, the setting value of the selected option appears.

2 In the option setup menu, when you shortly press the K1 switch, the values for Seg1 and Seg2 change. You can select the desired option.

(e.g. The value for Seg1 is 2 and the value for Seg2 is 1.)

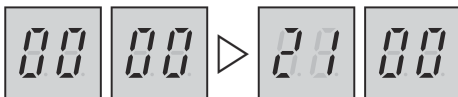

7. Low Ambient Cooling kit (This optional kit is sold only in North America)

7.6 Installation

- 1 In the desired option, if you shortly press the K2 switch, the values for Seg3 and Seg4 change. You can select the desired option.
(e.g. The value for Seg3 is 0 and the value for Seg4 is 1.)

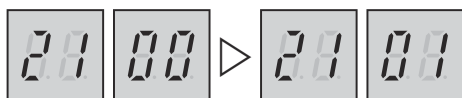

- 2 After selecting an option, if you press the K2 switch for 2 seconds, all 7-segment displays blink. If you enter the tracking mode, the option setting is saved.

⚠ CAUTION

- If not normally processed as mentioned above, the option setting is not saved.
- Before entry of the mode, if you want to return to the setting, press and hold the K1 switch to cancel the setting.
- If you want to reset to the factory defaults, in the option setting mode, press and hold the K4 switch.
 - If you press and hold the K4 switch, all the settings are reset to the factory defaults but the values are not saved yet. Only when the 7-segment display goes to the tracking mode by pressing and holding the K2 switch, the setting is saved.

Option	Entry Unit	SEG1	SEG2	SEG3	SEG4	Function	Remarks
LAC kit Setup	Main	2	1	0	0	Not applied (Factor default settings)	In case of installation of LAC kit (Low ambient kit)
				0	1	Applied	

Cautions for LAC kit (Low ambient cooling kit)

- If the main software version of the Outdoor unit is prior to June 2016, the LAC kit setup is unavailable. Update the firmware for your Main PBA(DB92-03752A)
- In the combination of modules, if the main software version of any Outdoor unit is prior to June 2016, upon LAC kit option setup, the E573 error occurs.
- If the option is not set, an error occurs so normal operation may not be possible.
- When the cooling operation is stopped due to E428 error, check for LAC kit failure or communication error between the outdoor unit and LAC kit.

7. Low Ambient Cooling kit (This optional kit is sold only in North America)

7.6 Installation

Features of LAC kit (Low ambient cooling kit)

- If LAC kit is installed, the cooling operation is possible up to -13°F.
- For more information about cooling performance of LAC kit, see the following table:

Performance Correction	Outdoor Temperature (°F, DB)			
	Less than 23	Less than 99	Less than 107	Greater than 107
Correction Factor	1.00	1.00	0.95	0.90

- Capacity Correction = Cooling Capacity x Correction Factor

Setting the address

Upon installation of LAC kit, set the address for the connected outdoor.

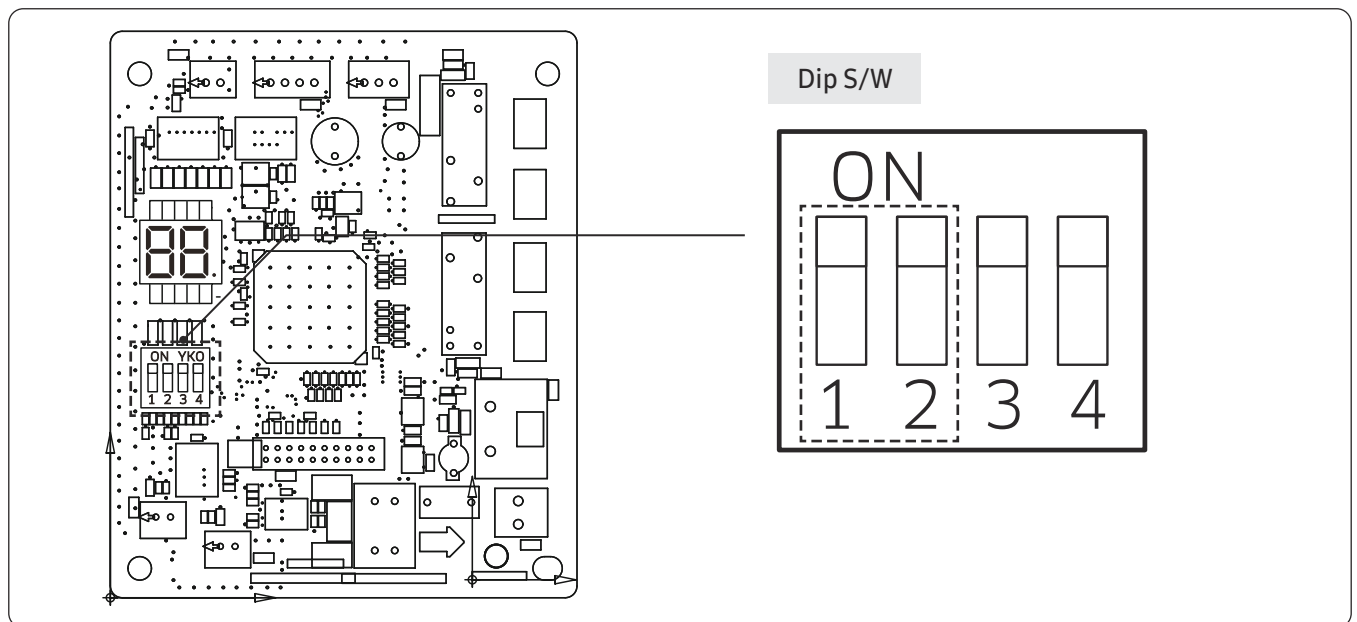

- Prior to power supply to the outdoor unit, set the switches. When address recognition is impossible after power supply, press the Reset button (K3 switch) on the outdoor unit.

Dip S/W		Function	Remarks	7-Segment
#1	#2			
ON (Default)	ON (Default)	Outdoor unit address: No.1	Connection to Main outdoor unit	88
ON	OFF	Outdoor unit address: No.2	Connection to Sub1 outdoor unit	89
OFF	ON	Outdoor unit address: No.3	Connection to Sub2 outdoor unit	8A
OFF	OFF	Outdoor unit address: No.4	Connection to Sub3 outdoor unit	8b

- After setup, check the LAC kit 7-segment display for normal address setup.

7. Low Ambient Cooling kit (This optional kit is sold only in North America)

7.6 Installation

Checking the version of LAC kit

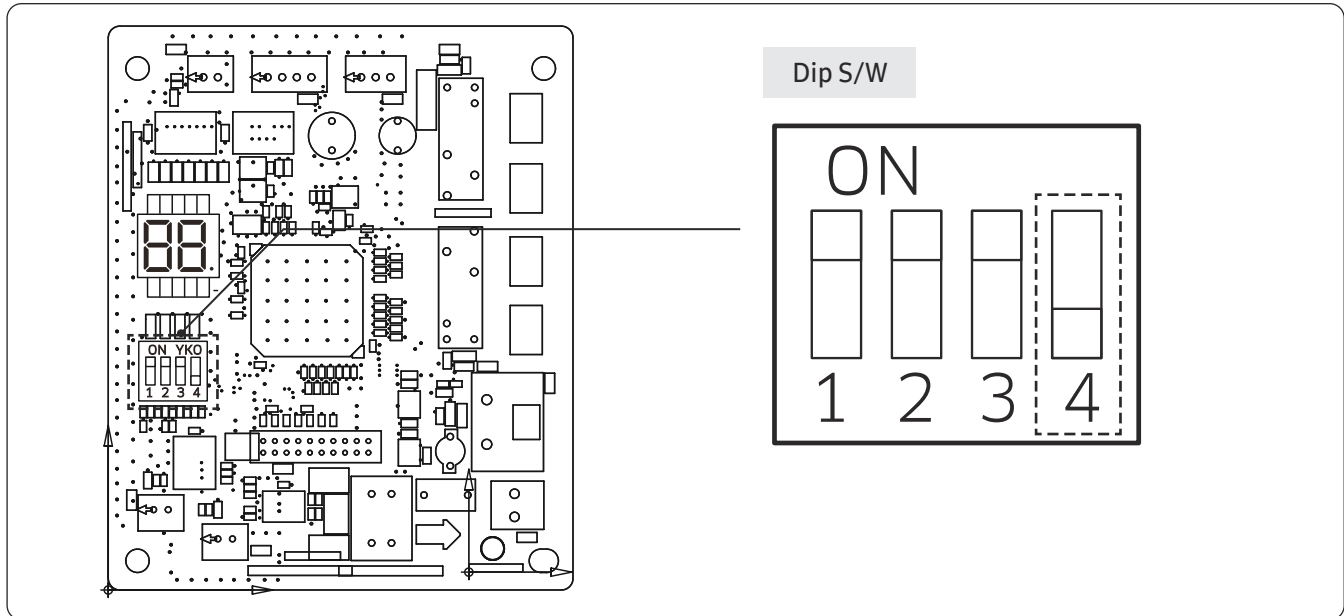

- To see the version of LAC kit, change to the dip switch #4.

Dip S/W	Function	Remarks
#4	Display of the LAC kit version	The version is displayed 5 times in the order of year, month, and date. ex) 16 / 08 / 01
ON → OFF		
OFF → ON		

- Error code

Error code	Description	Error Handling	7-Segment
E203	Communication error between LAC kit and outdoor unit	Upon LAC kit 7-Segment Error Display Error, the state is changed to LCA KIT Full Open.	

- In case of E203 Error
 - Check the communication cable connection status between the outdoor unit and LAC kit.

8. PDM (Pressure Drop Modulation) Kit

When the indoor unit is located at lower level than outdoor unit, allowable height difference is 110m
 (If the height difference is more than 50m, the PDM kit needs to be installed)

Model name of the PDM kit : MXD-A38K2A, MXD-A12K2A, MXD-A58K2A

Dimensional drawings

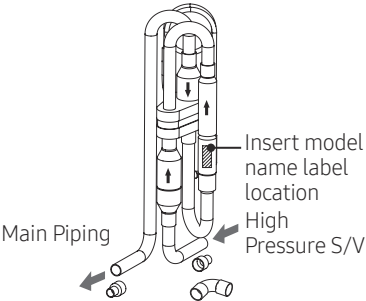
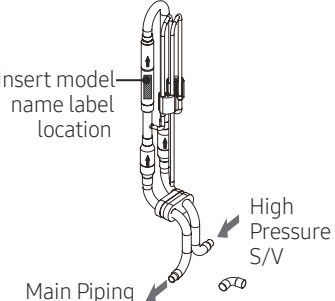
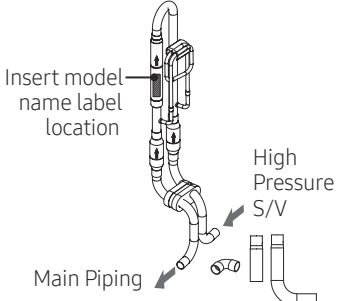
KIT model name	MXD-A38K2A	MXD-A12K2A	MXD-A58K2A
SET application model name	ADX080**~120** AM080**~120** AM072**/AA~120**/AA	ADX140**~160** AM140**~160** AM144**/AA	ADX180**~200** AM180**~300** AM168**/AA~216**/AA
Image			

- When needed, use the appropriate accessories (sockets) packed separately, for each product piping hole.
- Install on the outside of the outdoor unit if impossible to install inside. (Model: RD**, RVX**)
- If outdoor unit is 460V model (Model: AM**JH/AA, AM**JR/AA), PDM KIT requires special cabinet for installation on pipe tray. (Refer to PDM KIT Tray Diagram)

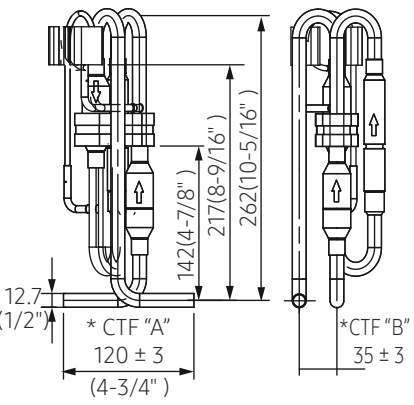
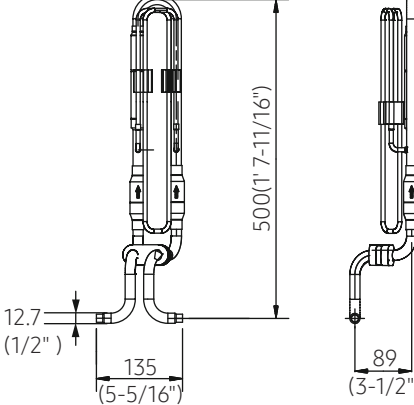
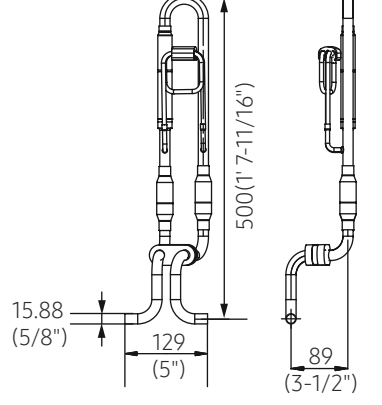
MXD-A38K2A	MXD-A12K2A	MXD-A58K2A
		

8. PDM (Pressure Drop Modulation) Kit

Connection method

- Before installing pressure drop modulation KIT, disassemble the lower cabinet.

H/R model (However, AM080~120** should be connected with the same way as H/P model.)

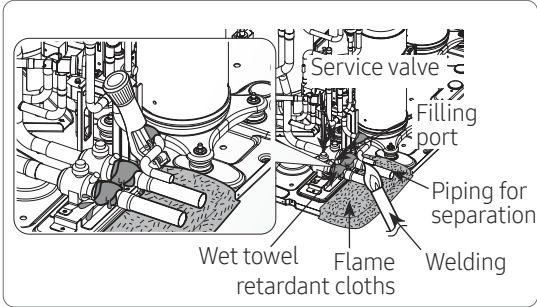

- Cut the liquid pipe for assembling pressure drop modulation KIT.(10mm from the left edge)

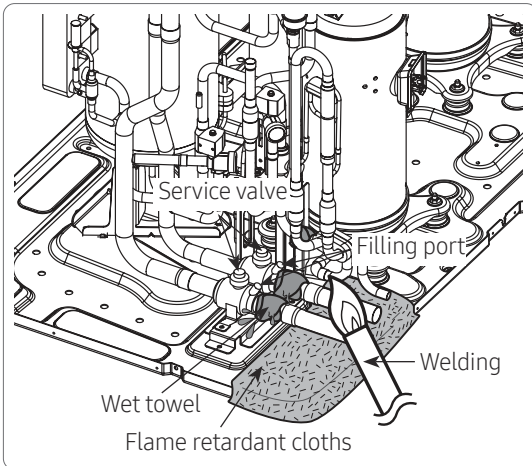

- After assembling the supplied pressure drop modulation kit with the sockets, weld them.

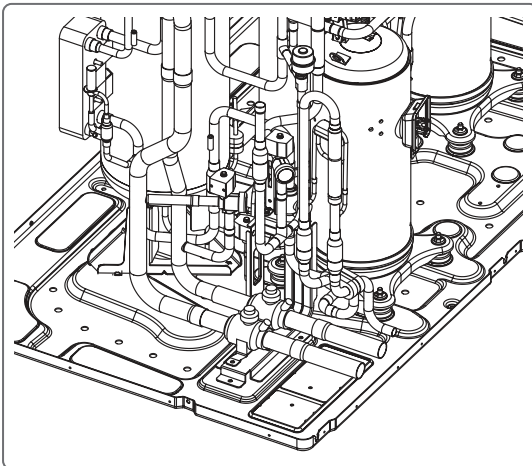

- The above is the completed image, make sure to check for gas leak before test operation.

H/P model



- Separate the front pipe of the high-pressure pipe in order to assemble the PDM KIT.

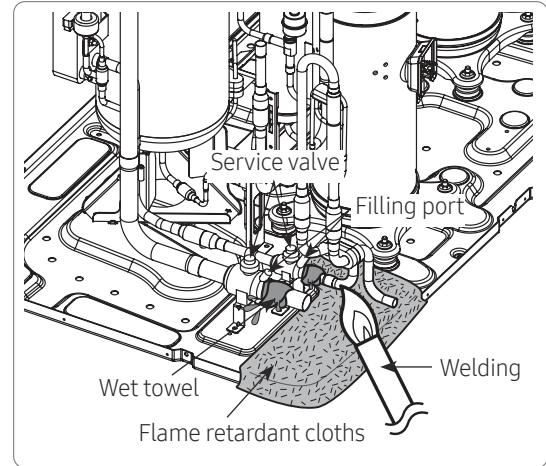

- Weld after assembling the prepared PDM KIT.

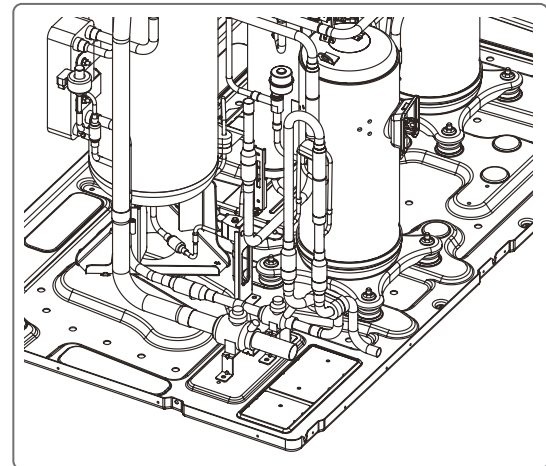

- The above is the completed image, make sure to check for gas leak before test operation.

8. PDM (Pressure Drop Modulation) Kit

⚠ CAUTION

Cautions while assembling KIT

- Assemble so that the check valve faces forward.
- Make sure to install vertically. (Install within $\pm 5^\circ$ to the left and to the right)

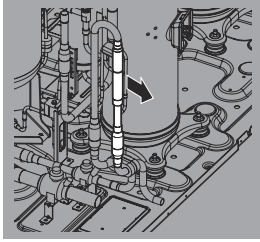

Installation method for AM240H× ~ 260H×
(DVM S Large A type)

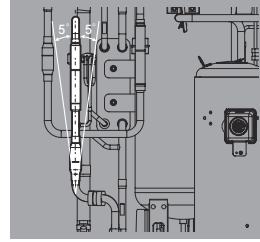
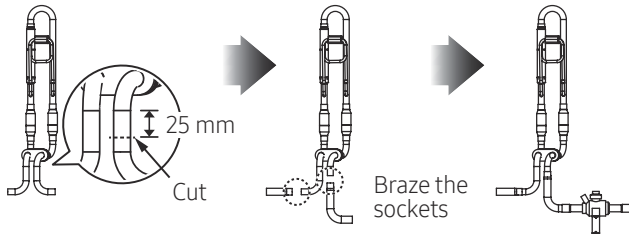

Installation method for AM240K× ~ 300K×
(DVM S Large B type)

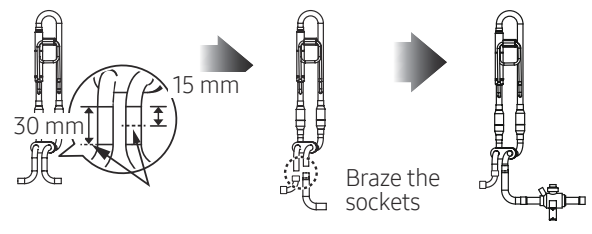

DVM PDM KIT Tray Diagram

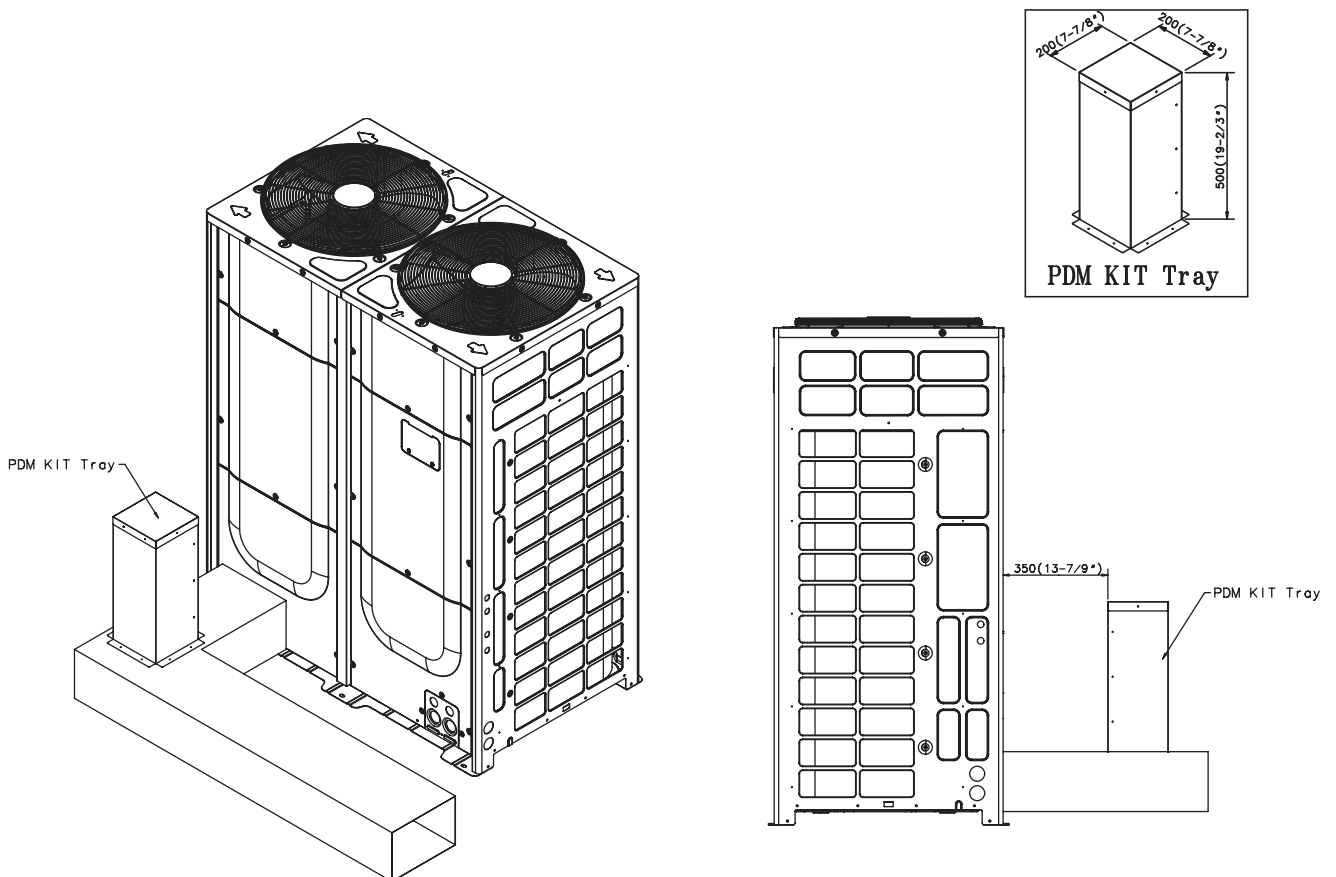

9. Branch kit

9.1. Y-joint

Model	Total indoor unit's capacities
MXJ-YA1509M	15.0 kW (51 MBH) and below
MXJ-YA2512M	Over 15.0~40.0 kW (51~136 MBH) and below
MXJ-YA2812M	Over 40.0~45.0 kW (136~154 MBH) and below
MXJ-YA2815M	Over 45.0~70.3 kW (154~240 MBH) and below
MXJ-YA3419M	Over 70.3~98.4 kW (240~336 MBH) and below
MXJ-YA4119M	Over 98.4~135.2 kW (336~461 MBH) and below
MXJ-YA4422M	Over 135.2 kW (461 MBH)

Dimensional drawing

		(Unit : mm)	
Port	Model	MXJ-YA1509M	MXJ-YA2512M
Liquid side			
Gas side			
Port	Model	MXJ-YA2812M	MXJ-YA2815M
Liquid side			
Gas side			

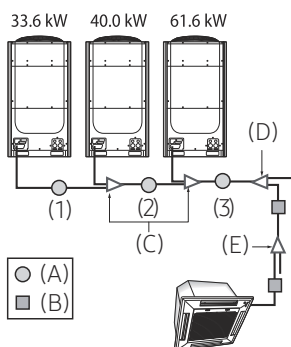

- First branch joint (D)
Make a selection according to outdoor unit capacity.
- Branch joint (E)
Select a branch joint according to the sum of indoor unit capacity which will be connected after the branch. However, if the size of the pipe between branch joints (E) is bigger than the size of the pipe connected to the outdoor unit (D), apply the pipe size (D).

9. Branch kit

9.1. Y-joint

Port	Model		
	MXJ-YA3419M	<p>② x 2 EA ⑩ x 2 EA</p>	<p>② x 2 EA ⑩ x 2 EA</p>
	MXJ-YA4119M	<p>② x 2 EA ⑩ x 2 EA</p>	<p>② x 2 EA ⑩ x 2 EA</p>
	MXJ-YA4422M	<p>① x 1 EA ③ x 2 EA</p>	<p>③ x 1 EA ④ x 1 EA ⑤ x 1 EA ⑥ x 1 EA</p>

(Unit : mm)

Reducer

①		②		③		④	
⑤		⑥		⑦		⑧	
⑨		⑩		⑪		⑫	

(Unit : mm)

9. Branch kit

9.2. Y-joint for HR (High pressure gas)

Model	Total indoor unit's capacities
MXJ-YA1500M	22.4 kW (76 MBH) and below
MXJ-YA2500M	Over 22.4~70.3 kW (76~240 MBH) and below
MXJ-YA3100M	Over 70.3~ 135.2 kW (240~461 MBH) and below
MXJ-YA3800M	Over 135.2 kW (461 MBH)

Dimensional drawing

(Unit : mm)

MXJ-YA1500M	MXJ-YA2500M
MXJ-YA3100M	MXJ-YA3800M

Reducer

(Unit : mm)

<p>①</p>	<p>②</p>	<p>③</p>	<p>④</p>
----------	----------	----------	----------

9. Branch kit

9.3. Header joint

Model	Total indoor unit's capacities	The maximum quantity of connection
MXJ-HA2512M	45.0 kW(154 MBH) and below	4
MXJ-HA3115M	70.3 kW(240 MBH) and below	8
MXJ-HA3819M	Over 70.3 kW (240 MBH)	8

Dimensional drawing

(Unit : mm)

Port	Model	MXJ-HA2512M	MXJ-HA3115M
Liquid side		<p>① x 4 EA ② x 1 EA ⑦ a x 1 EA</p>	<p>① x 8 EA ④ x 1 EA ⑦ b x 1 EA</p>
Gas side		<p>③ x 4 EA ⑤ x 1 EA ⑧ x 1 EA</p>	<p>③ x 8 EA ⑥ x 1 EA ⑧ x 2 EA</p>
Port	Model	MXJ-HA3819M	
Liquid side		<p>① x 8 EA ⑦ c x 1 EA</p>	
Gas side		<p>③ x 8 EA ⑧ x 2 EA</p>	

Reducer

(Unit : mm)

①		②		③		④	
⑤		⑥		⑦		⑧	

9. Branch kit

9.4. Out door joint

Model	Total indoor unit's capacities
MXJ-TA3819M	Below 135.2 kW (48HP, 461.3 MBH)
MXJ-TA3419M	
MXJ-TA4422M	Above 140.2 kW (50HP, 478.4 MBH)
MXJ-TA4122M	

Dimensional drawing

(Unit : mm)

Port	Model	MXJ-TA3819M	MXJ-TA3419M
Liquid side			
Gas side			
Port	Model	MXJ-TA4422M	MXJ-TA4122M
Liquid side			
Gas side			

Reducer

(Unit : mm)

①		②		③	
④		⑤		⑥	

9. Branch kit

9.5. Out door joint for HR (High pressure gas)

Model	Total indoor unit's capacities
MXJ-TA3100M	Below 135.2 kW(48HP, 461.3MBH)
MXJ-TA3800M	Above 140.2 kW(50HP, 478.4 MBH)

Dimensional drawing

(Unit : mm)

MXJ-TA3100M	MXJ-TA3800M
<p>① x1 EA ③ x1 EA</p>	<p>② x1 EA ③ x1 EA ④ x2 EA</p>

Reducer

(Unit : mm)

<p>①</p>	<p>②</p>	<p>③</p>	<p>④</p>
----------	----------	----------	----------





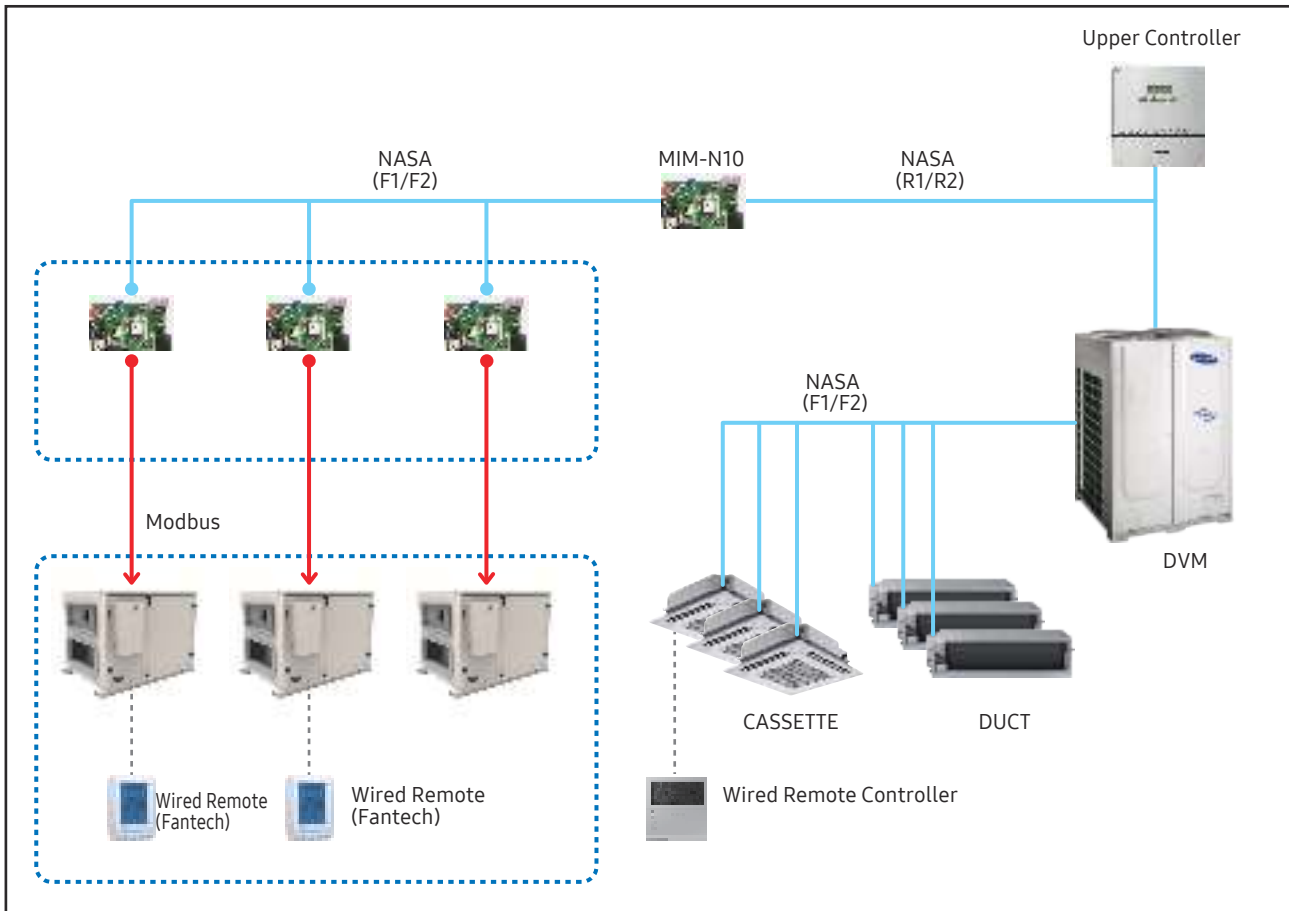

10. ERV Kit Modbus Interface Module, (This optional kit is sold only in North America)

10.1. Feature



- The local ERV product and Samsung communication system are linked through the ERV kit.

Product and components (MXD-K200VN)

Name	ERV Kit	DC power cable (12 V)	Communication cable	Case		Cable tie
Shape						

10. ERV Kit Modbus Interface Module, (This optional kit is sold only in North America)

10.2. Spec sheet

Type			Modbus Interface Module	
Model			MXD-K200VN	
Power Supply		V, Hz, #	DC 12V	
Communication		-	NASA, MODBUS	
Dimension / Weight	Net Dimension (WxHxD)	mm	80x21.6x50	
	Gross Dimension (WxHxD)	mm	236x58x162	
	Net Weight	kg	0.25	
	Gross Weight	kg	0.033	
Max. Connection Length	RS485	M	1,000	
Operation Range	Temp.	°C	-10°C~50°C	
	Humidity	RH%	10~90%	

10.3. Dimension and Drawing

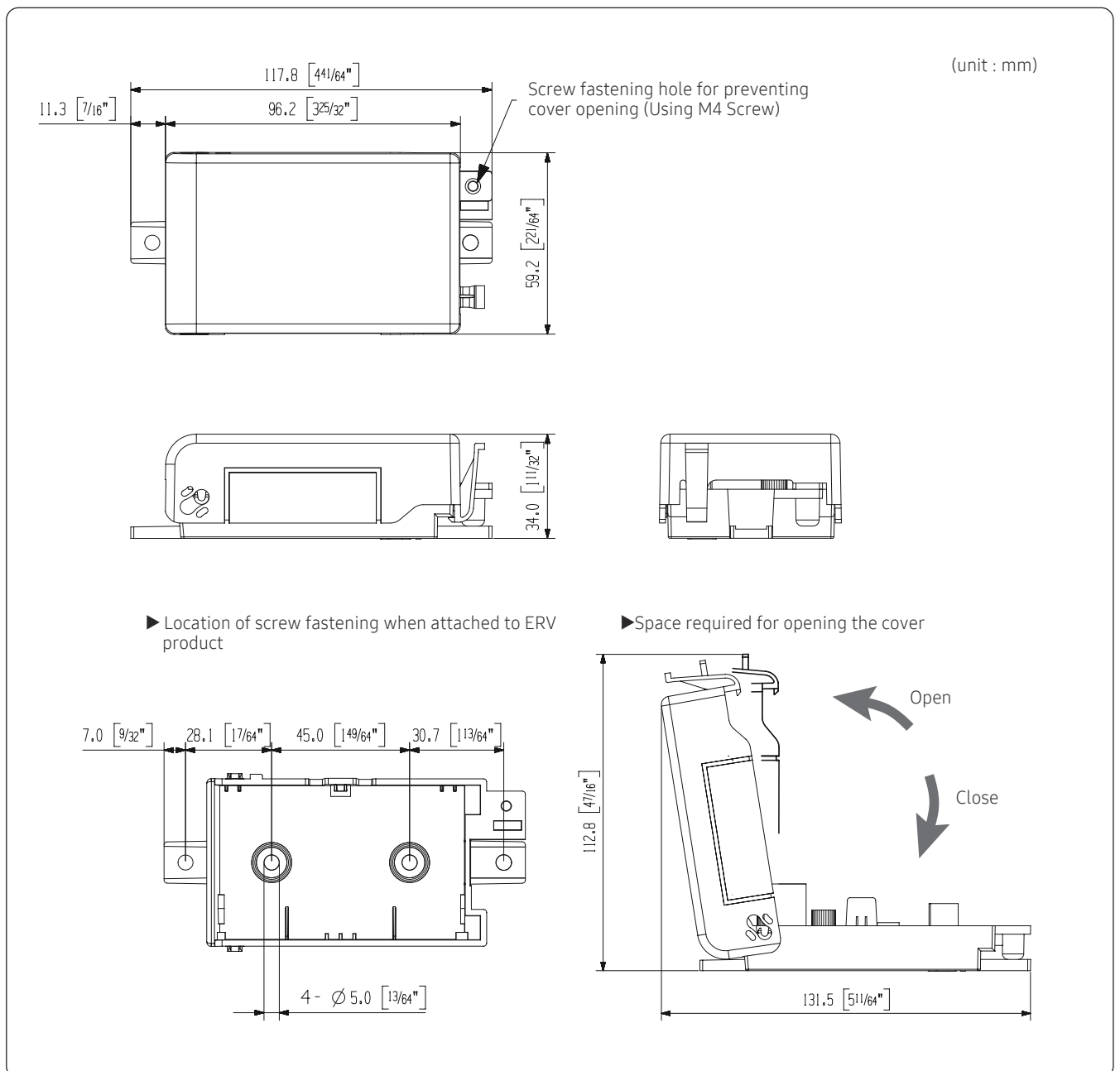

10. ERV Kit Modbus Interface Module, (This optional kit is sold only in North America)

10.4. Wiring Diagram

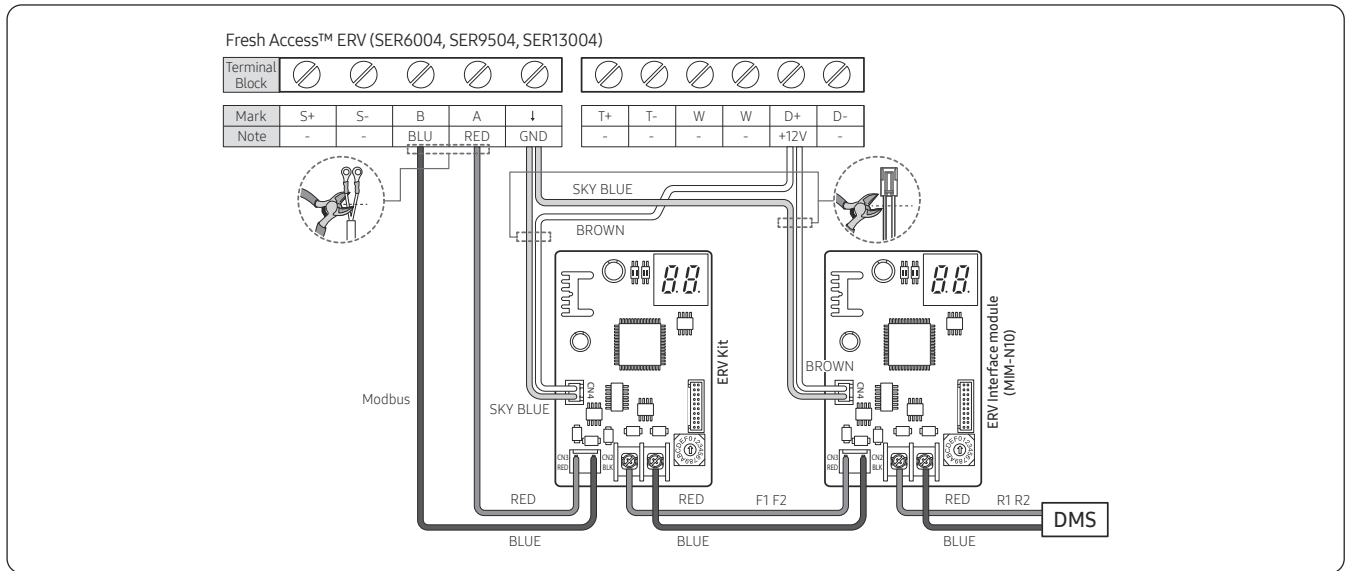

- Example of ERV Kit installation
 (You can connect 1 ERV unit to ERV KIT and connect up to 16 ERV KIT to each ERV Interface module.)

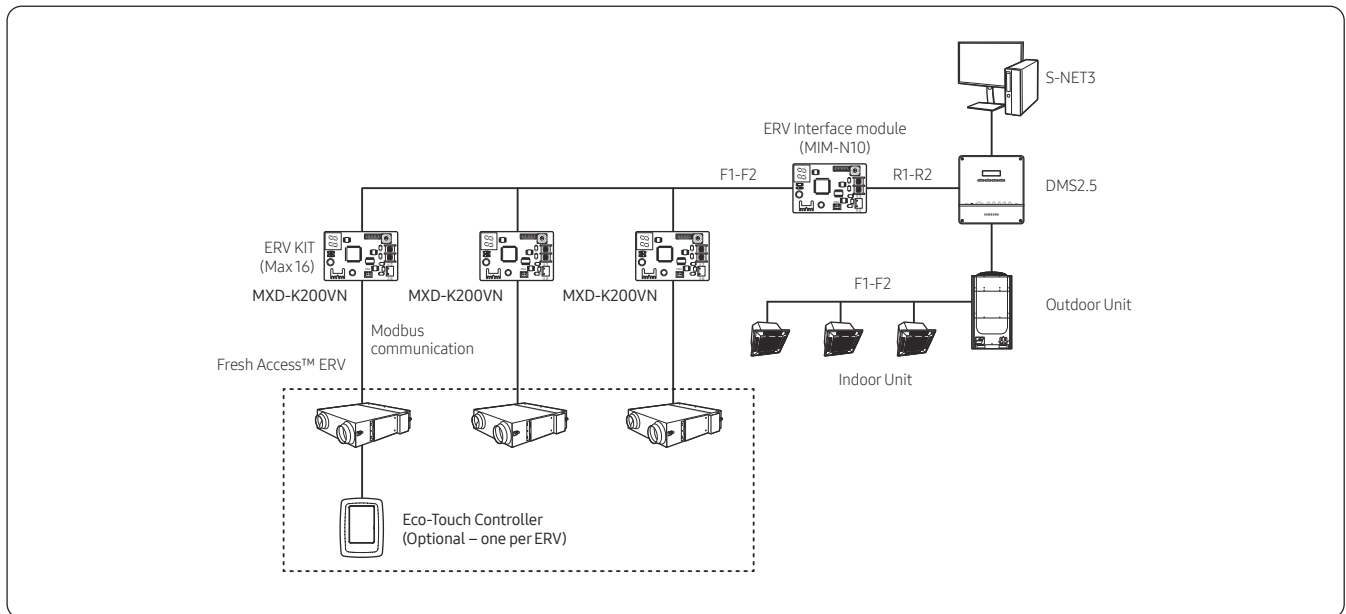

10. ERV Kit Modbus Interface Module, (This optional kit is sold only in North America)

10.5. Install

Connecting the ERV Kit to the DMS

- 1 After attaching a case to the side of the Fresh Access™ ERV, install the ERV KIT.
 - 2 Connect the power cable and communication cable of the ERV KIT.
- When a ERV KIT is installed, you can perform a centralised control of DMS.

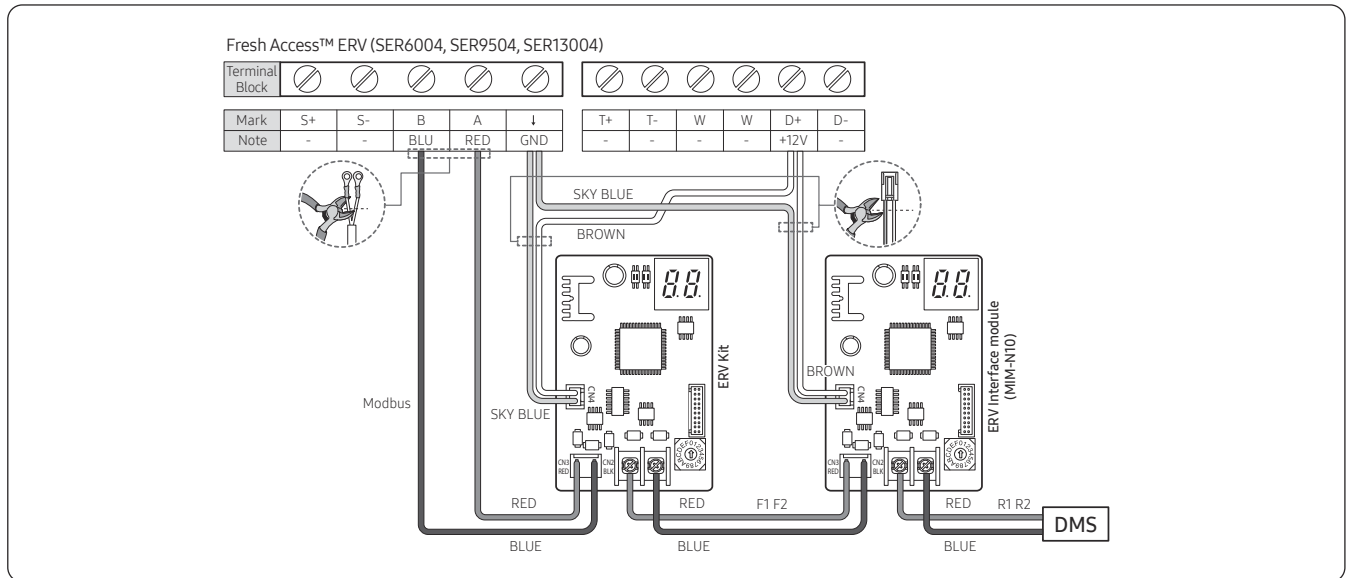

⚠ CAUTION

- You should switch off the power supply and disconnect the power cable. (Abnormal operation of the product may occur due to the electric problem.)

10. ERV Kit Modbus Interface Module, (This optional kit is sold only in North America)

10.5. Install

3 Set the address of the ERV Kit.

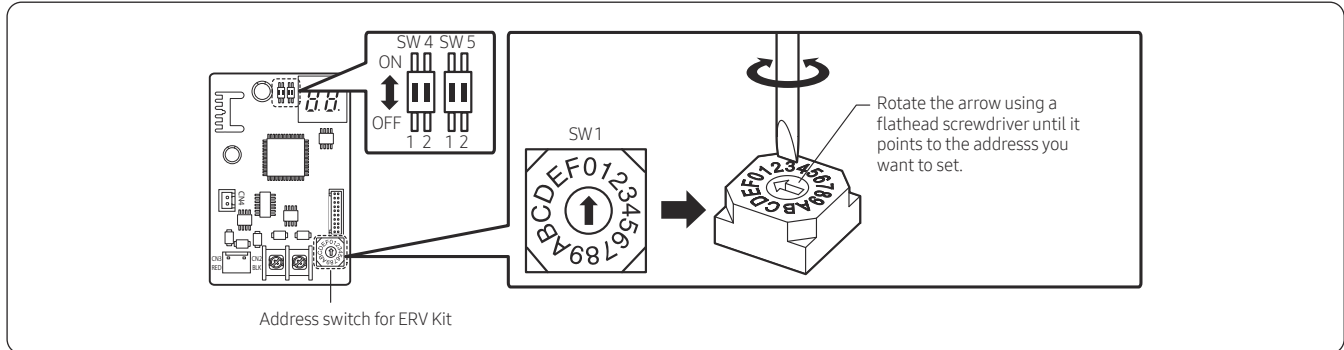

- SW1: Address switch, set the address within 0~F (0~15) (Address between each ERV Kit should be set differently)
- SW4 #1: Option switch, which sets automatic/manual address setting when ERV Kit and Fresh Access™ ERV have been installed.
 - To set automatic/manual address setting, set as in the following table. (Default: automatic address setting) (This function is only applicable when new communication upper level controller is connected.)

	1		2	
	ON	OFF	ON	OFF
SW4	Manual address	Automatic address	No function	
SW5	No function			

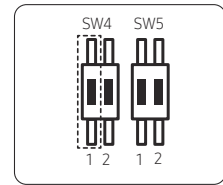

- When connecting a 485 communication cable between the ERV Kit and the DMS, be sure to match the polarity. If the polarity does not match, communication is impossible.

⚠ CAUTION

- Both distances from the ERV Kit to the DMS must be within 3,280 feet.
- You should switch off the power supply before installation.
- The wiring should be installed in accordance with electric wiring regulations and should be placed inside the wall so that users cannot touch them.

10. ERV Kit Modbus Interface Module, (This optional kit is sold only in North America)

10.5. Install

Checking Operation

LED indication

- 1 When communication between the ERV Kit and an ERV(3rd party) is proceeding, the Y-GRN LED blinks.
- 2 When communication between the ERV Kit and DMS or ERV Interface module(MIM-N10), RED LED blinks.

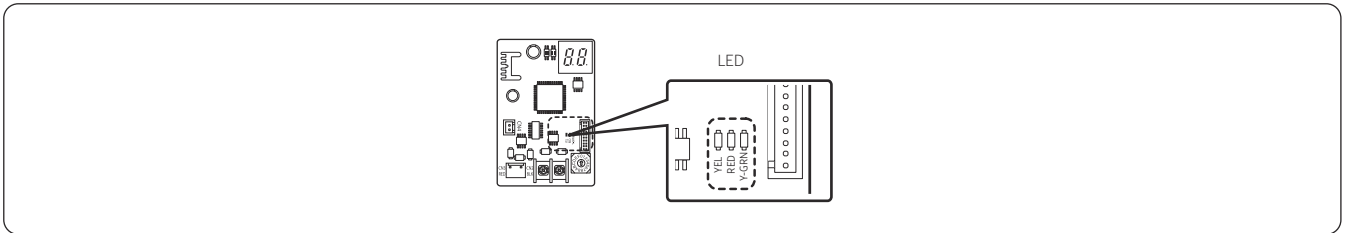

7-SEGMENT indication

The tracking of ERV KIT will proceed as the following

Display in normal operation

- "Ad" and "***" are displayed on the first and second segment for 1 second.

Example)

Address	SEGMENT
00	Ad ↔ 00
15	

- The address of the ERV KIT can be set to a value from 0 to 15.

Display when an error occurs

- "E" and "*" are displayed on the first and second segments for 1 second. → Displays "*" and "*" for 1 second. (This action will repeat until the error is corrected)

Example)

ERROR CODE	SEGMENT
E101	

10. ERV Kit Modbus Interface Module, (This optional kit is sold only in North America)

10.5. Install

Note on ERV KIT and DMS operation

- Set remote controller settings.

You can select Enable RC and Disable RC.

When selecting [Disable RC], Fresh Access™ ERV unit by wired remote controller is not possible, ERV unit control is only available in DMS2.5 web page.



Error Codes

Display	Explanation	Error Source
E108	Error due to repeated communication address	ERV KIT
E109	Communication error due to ERV KIT address incomplete.	ERV KIT
E111	Modbus communication error (when COMM KIT cannot receive signals)	ERV Kit ↔ Fresh Access™ ERV
E162	EEPROM Hardware ERROR	ERV KIT
E202	ERV KIT/ERV Interface module (MIM-N10) communication error (3 min)	ERV Kit ↔ ERV Interface Module

10. ERV Kit Modbus Interface Module, (This optional kit is sold only in North America)

10.6. Compatible model

Local ERV(Modbus Communication)

Model	Type	Airflow Capacity	Manufacturer
SER6004	Fresh Access™ ERV	Up to 606 cfm @ 0.4" PS	Fantech (Systemair)
SER9504	Fresh Access™ ERV	Up to 970 cfm @ 0.4" PS	Fantech (Systemair)
SER13004	Fresh Access™ ERV	Up to 1300 cfm @ 0.4" PS	Fantech (Systemair)

Control layer(R1/R2) Controller(NASA Communication)

Model	Name	Type
MIM-D01AUN	DMS2.5	Intergrated Management System
MST-P3P	S-NET3	
MCM-A300N	Touch Centralized Controller	Centralized Control System
MCM-A202DN	On/Off Controller	
MIM-H03UN	Wi-Fi Kit	
MIM-B17BUN	BACnet Gateway	Gateway
MIM-B18BUN	Lonworks Gateway	

Set layer(F1/F2) Controller(NASA Communication)

Model	Name	Type
MIM-N10	ERV Interface Module	Interface

11. Differential Pressure Switch (This optional kit is sold only in Europe)



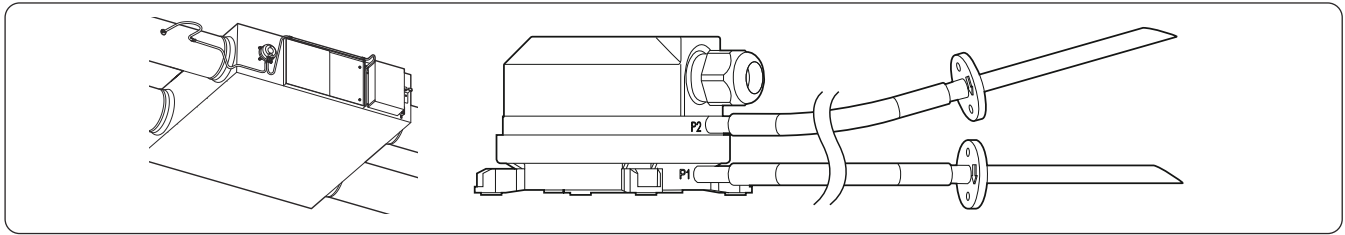



11.1. Feature

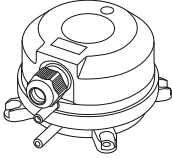
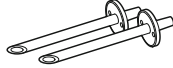
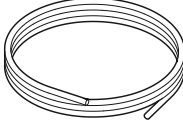

- Filter differential pressure switch for ERV.

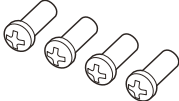
※ When ANxxxJSKLKN/EU is installed in a country which is subject to Commission regulation (EU) No 1253/2014 implementing Directive 2009/125/EC of the European Parliament and of the Council with regard to Ecodesign requirements for ventilation units, be sure to install a differential pressure switch (MOS-P1050), which can measure pressures at the front and back of the filter, together with the product.

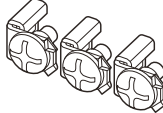
Product and components(MOS-P1050)

Name	Differential Pressure Switch	Plastic Tube	PVC Tube	Screw (PH, M4, L10)
Shape				
Name	Screw (PH, M3, L10)	Screw (TH, M4, L8)	Pin-terminal connector	Holder Wire
Shape				

11. Differential Pressure Switch (This optional kit is sold only in Europe)

11.2. Spec sheet

Type			Differential Pressure Switch
Model Code	Model Code	-	MOS-P1050
Pressure Spec	Adjustment range	Pa	50 ~ 500
	Switching defferential	Pa	20
	Repeatability of the switching pressure	Pa	±2.5 %, min. ±5 Pa
Electrical Spec	Electrical rating	A / V	max. 0.1 A / 24 VDC
Temperature range	Medium & Operation range	°C	-20 ~ +85
	Storage range	°C	-40 ~ +85
Dimension / Weight	Net Dimension (WxHxD)	mm	102x86x57.5
	Gross Dimension (WxHxD)	mm	236x162x98
	Net Weight	kg	0.12
	Gross Weight	kg	0.44
Mechanical Spec	IP grade	-	With Cover : IP 54 Without Cover : IP 00
	Mechanical working life	-	Over 10 ⁶ switching operations.

11.3. Dimension and Drawing

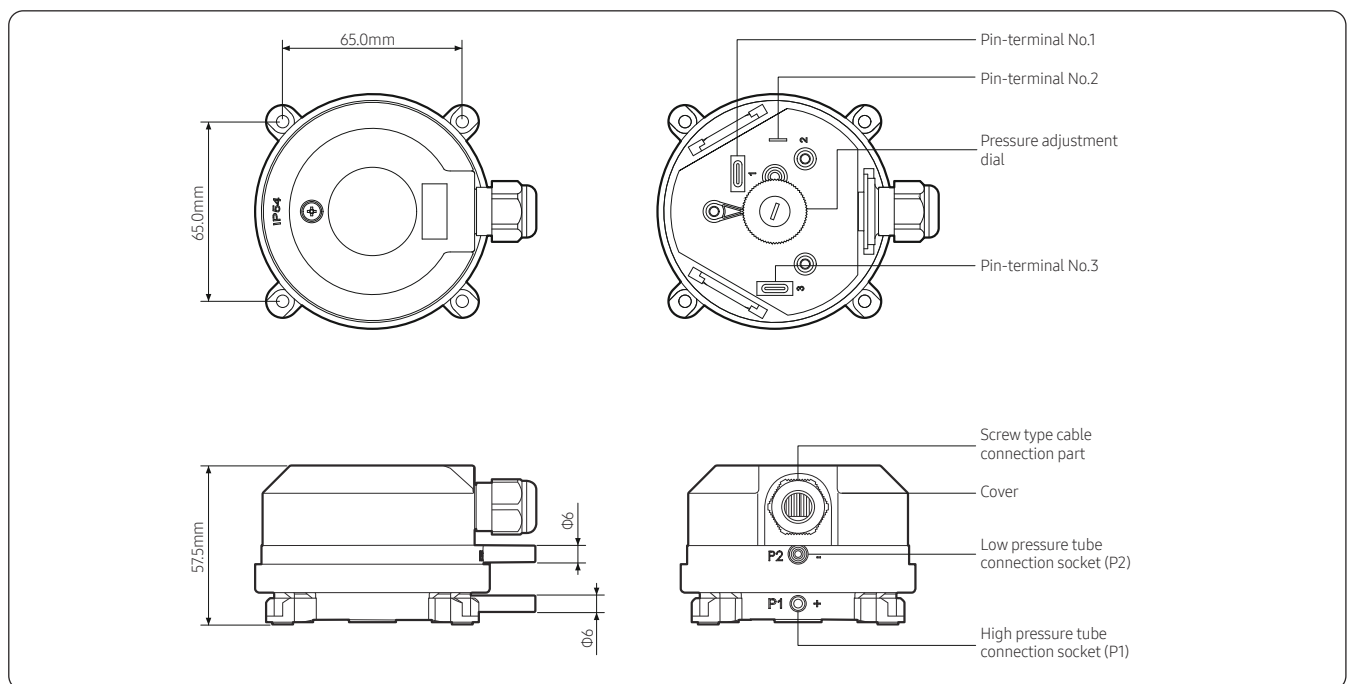

11. Differential Pressure Switch (This optional kit is sold only in Europe)

11.4. Wiring Diagram

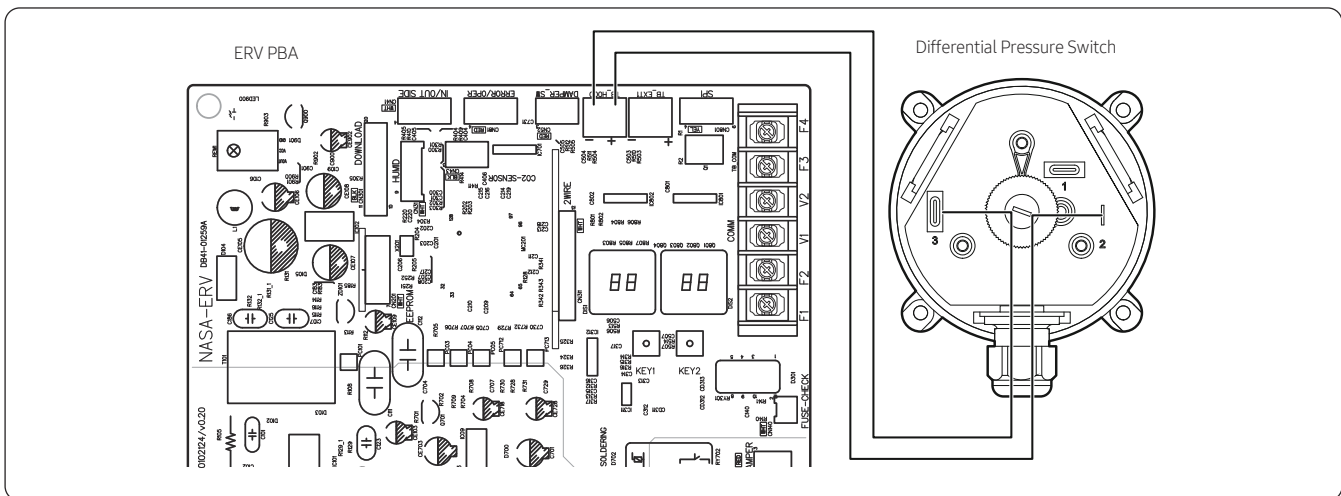

- Connect the connecting wires to the pin-terminals No. 2 and No. 3 located on both sides to the differential pressure switch dial, and then connect the opposite ends of the connecting wires to the HOOD terminals on the ERV PBA.

11.5. Install

Installing the differential pressure switch onto the ERV

- 1 Connect the PVC tubes to the two sockets on the side of the differential pressure switch, and connect the plastic tubes to the opposite side as shown in the figure.

 - Connect the low pressure side PVC tube to the socket P2 (upper socket) and the high pressure side PVC tube to the socket P1 (lower socket).
 - Cut the PVC tube to fit the size of the product.

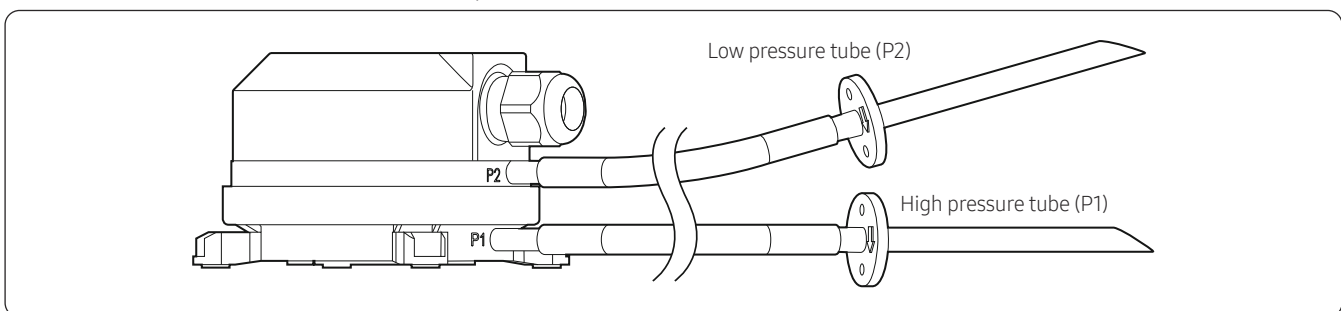

11. Differential Pressure Switch (This optional kit is sold only in Europe)

11.5. Install

2 Untighten the screws on the ERV, as marked in the figure, and then assemble the differential pressure switch using screws (PH, M4, and L10).

- AN026**

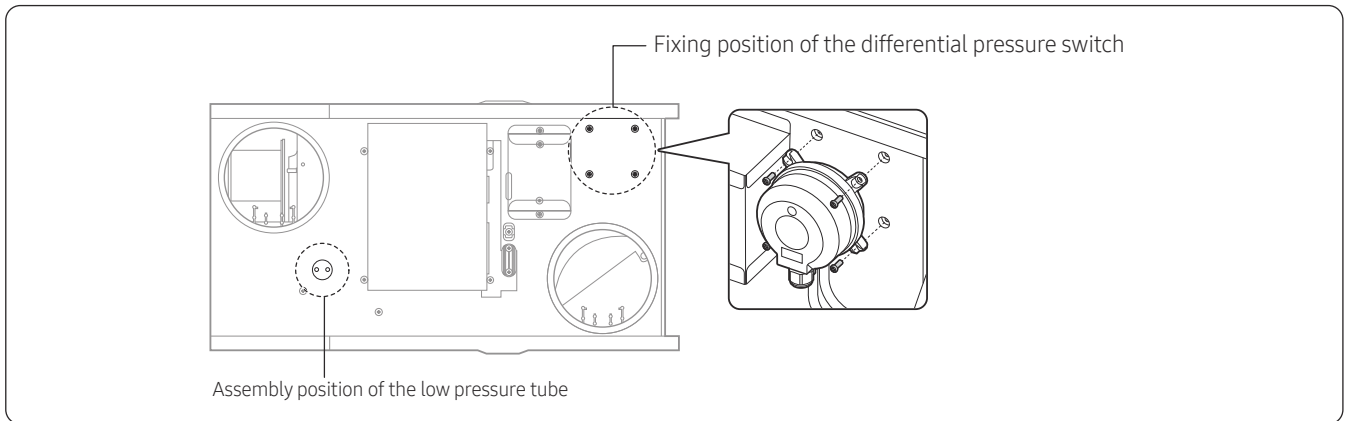

- AN035**, - AN050**, AN080**, - AN0100**

- The screws are covered with insulation at the insulation cutting positions indicated by the + symbols.

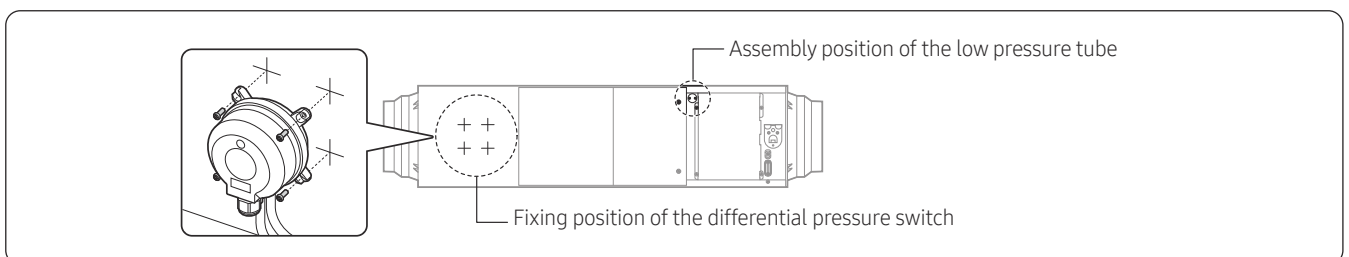

⚠ CAUTION

- When installing the differential pressure switch, make sure that its sockets to which the tubes are connected face downward (based on product installation). Failure to do so may cause moisture to enter the switch or errors to occur in differential pressure measurement.

3 Disassemble the circular cover next to the electrical control part of the ERV, and then assemble the low pressure plastic tube connected to the differential pressure switch socket P2. Then, fix the low pressure PVC tube to the product using the holder wire as shown in the figure.

- Disassembling the circular cover and assembling the plastic tube

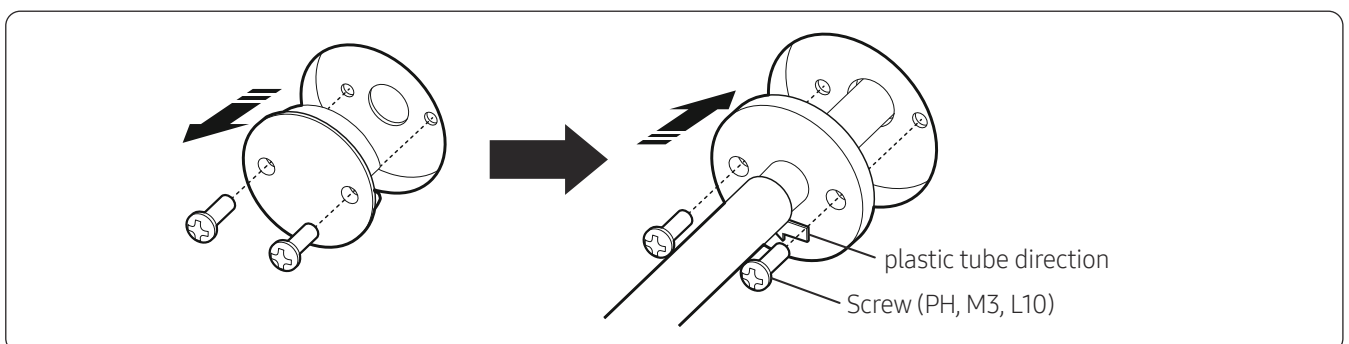

📄 NOTE

- Make sure that the direction of the plastic tube as indicated by the arrow in the figure is identical with the air flow direction.

11. Differential Pressure Switch (This optional kit is sold only in Europe)

11.5. Install

- AN026**

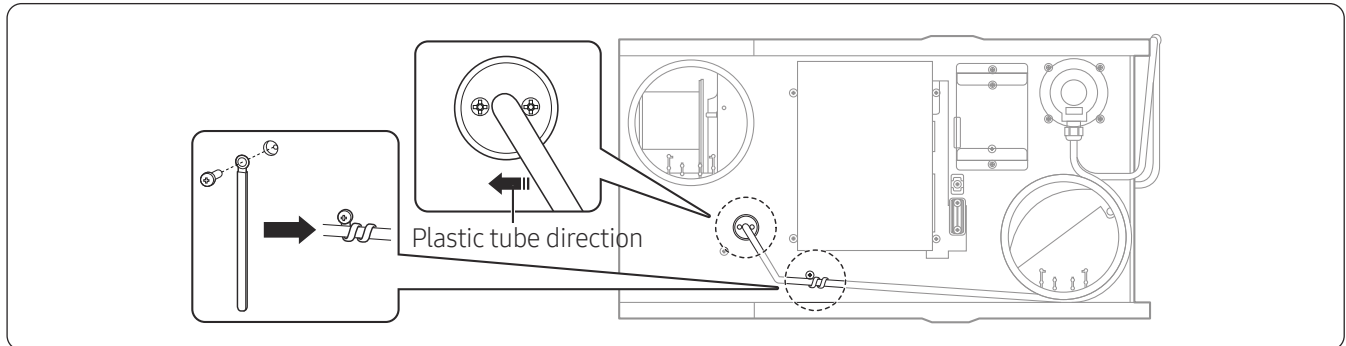

- AN035**, - AN050**, AN080**, - AN0100**

- Fix the PVC tube using the holder wire located at the position indicated in the figure.

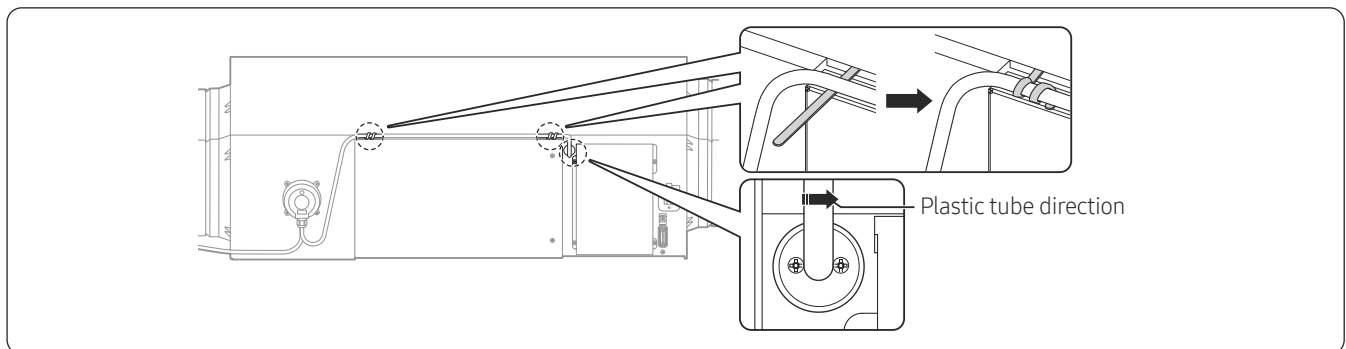

⚠ CAUTION

- In any case, be careful not to twist or press the PVC tube. Failure to do so may cause errors in pressure measurement, leading to product malfunction.
- If the direction of the plastic tube is not identical with the air flow direction, errors may occur in pressure measurement, leading to product malfunction.

11. Differential Pressure Switch (This optional kit is sold only in Europe)

11.5. Install

- 4 Assemble the high pressure plastic tube(P1) to the OA duct installed on site, and then fix the high pressure PVC tube using the holder wire.
- Assemble the plastic tube so that its direction is identical with the air flow direction in the OA duct.
 - Assemble the plastic tube at a position which is 300 to 500 mm away from the product.
 - Assemble the plastic tube to a side of the OA duct.
 - **AN026****
 - Assemble the holder wire to the inspection cover assembly screw on the top of the product, and then fix the PVC tube.
 - Assemble the plastic tube to the external OA duct, and then fix the PVC tube using the holder wire.

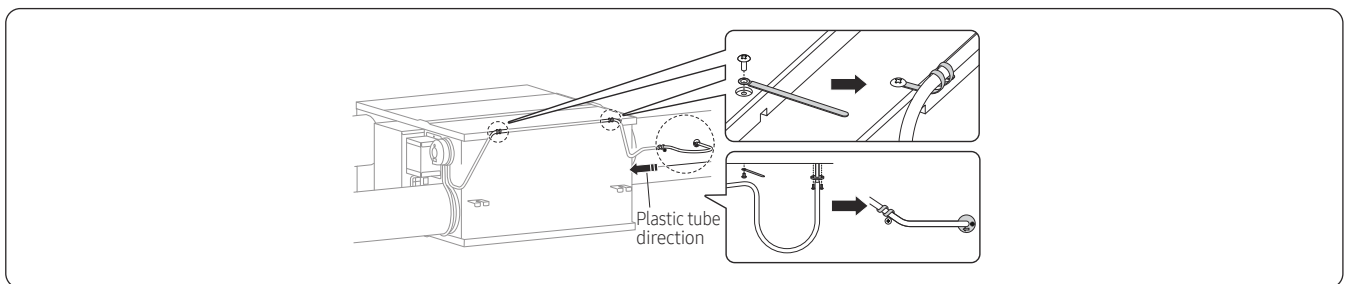

- **AN035**, - AN050**, AN080**, - AN0100****
 - Assemble the plastic tube to the external OA duct, and then fix the PVC tube using the holder wire.

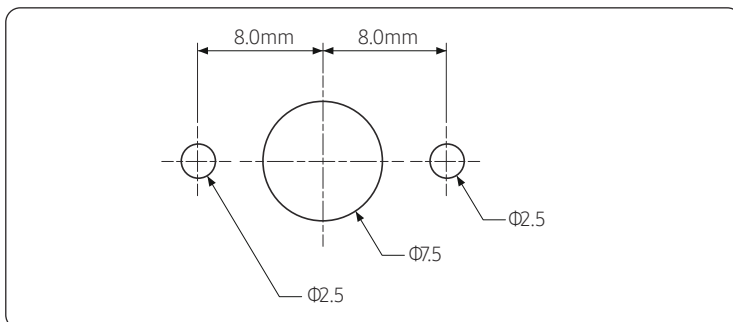
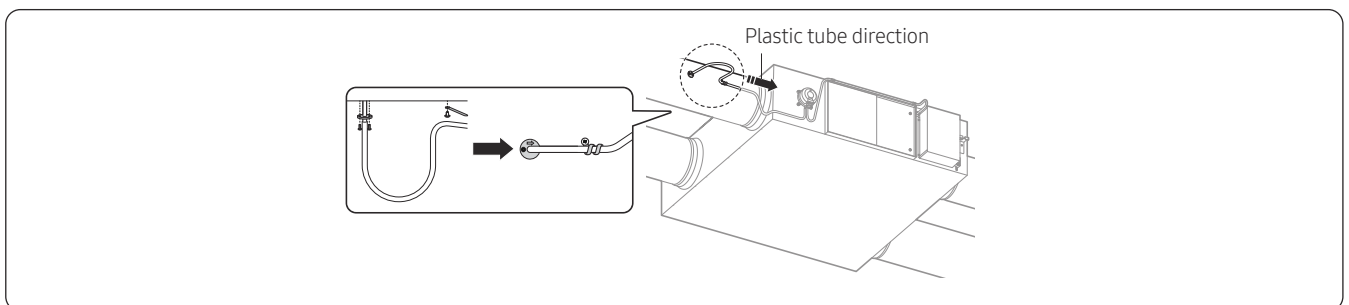

NOTE

- To assemble the plastic tube to the OA duct, it is required to drill holes on the duct. For the hole sizes, refer to the figure:

CAUTION

- In any case, be careful not to twist or press the PVC tube. Failure to do so may cause errors in pressure measurement, leading to product malfunction.
- If the direction of the plastic tube is not identical with the air flow direction, errors may occur in pressure measurement, leading to product malfunction.
- If the plastic tube is assembled below the OA duct, the plastic tube can be blocked by dirt or dust. Be careful not to assemble the plastic tube below the OA duct.

11. Differential Pressure Switch (This optional kit is sold only in Europe)

11.5. Install - Wire

Connecting the connecting wires between the differential pressure switch and the ERV PBA

- 1 Untighten the screw (1 EA) of the differential pressure switch, disassemble the cover, and then pass the cable through the screw type cable connection part.

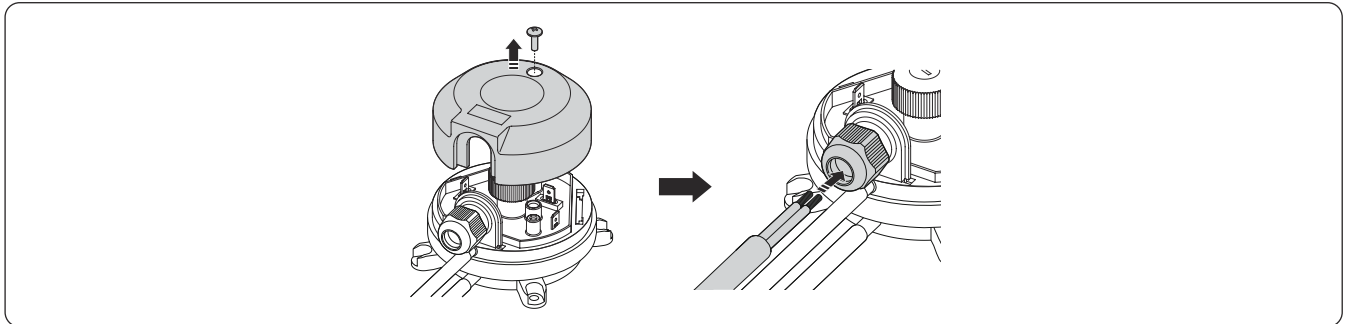

- 2 Apply a crimp type ring connector to each connecting wire located at the body side of the differential pressure switch, and then connect a pin-terminal connector, as shown in the figure.

- The cable and the crimp type ring connector do not come with the product and must be purchased on site.

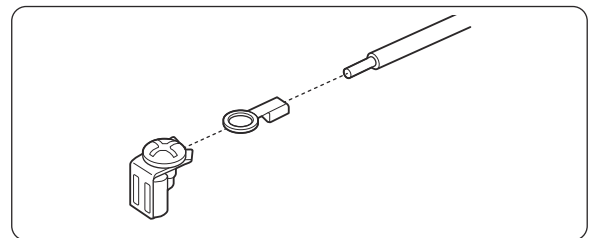

- 3 Connect the connecting wires to the pin-terminals No. 2 and No. 3 located on both sides to the differential pressure switch dial, and then connect the opposite ends of the connecting wires to the HOOD terminals on the ERV PBA.

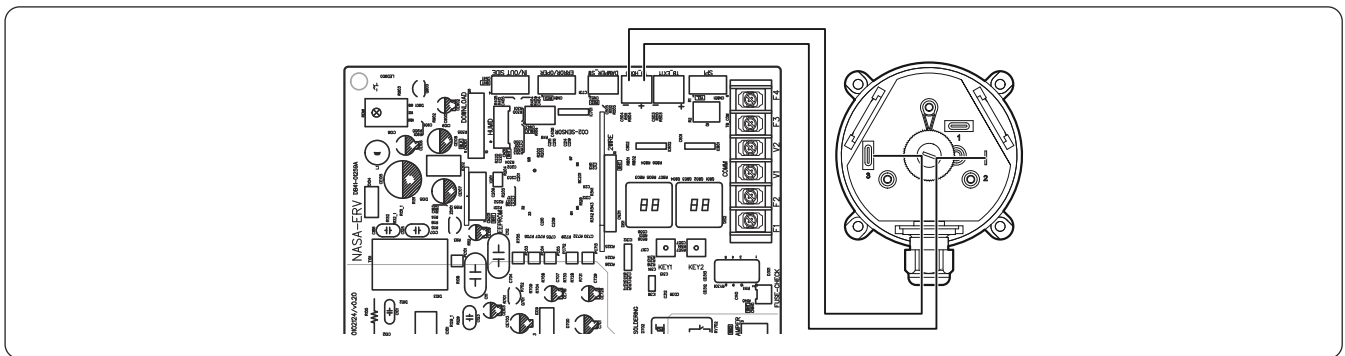

- 4 Rotate the screw type connection part clockwise to seal the opening appropriately in accordance with the thickness of the connecting wires.

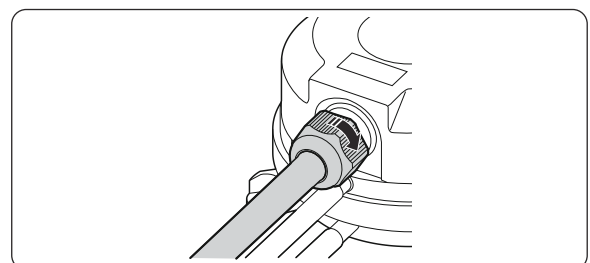

⚠ CAUTION

- Be sure to switch off the power supply before installation. (Failure to do so may cause electrical problems, leading to abnormal operation of the product.)
- The wiring must be installed in compliance with electrical wiring regulations.
- If the diameter of the connecting wire is less than 5mm, the sealing of the screw type cable connection part may not be complete.

11. Differential Pressure Switch (This optional kit is sold only in Europe)

11.5. Install - Wire

Setting using the differential pressure switch

- 1 Rotate the dial located at the center of the differential pressure switch until the number pointed by the yellow arrow becomes equal to the differential pressure setting value of the product.
(Refer to the following table for the setting values by model.)

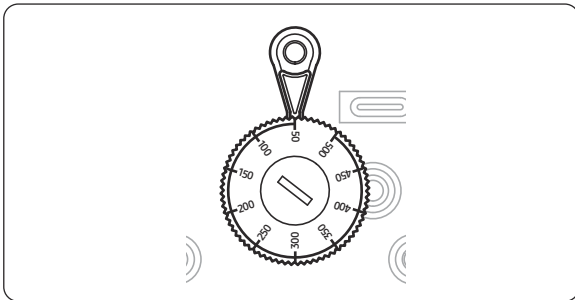

Model	Differential pressure setting
AN026JSKLKN/EU	220
AN035JSKLKN/EU	200
AN050JSKLKN/EU	250
AN080JSKLKN/EU	280
AN100JSKLKN/EU	310

NOTE

- When rotating the dial to set the differential pressure, be sure to rotate it in the direction that the number increases from the minimum value to the setting value. If you rotate the dial in the direction that the number decreases to the setting value, errors may occur in differential pressure measurement.

WARNING

- Be sure to set the differential pressure while the product is turned off. If it is not turned off, an electric shock may occur due to your contact with a peripheral wire.
- 2 Close the cover of the differential pressure switch, and then tighten the screw.
 - 3 Set SEG17 of the installation option 1 (O2 mode) of the product to 1. (The ANxxxJSKLKN / EU models ship with being set to the factory default 1.)

11.6. Compatible model

Type	Chassis	Model
Commercial ERV	Small	AN026JSKLKN/EU
Commercial ERV	Middle	AN035JSKLKN/EU
Commercial ERV	Middle	AN050JSKLKN/EU
Commercial ERV	Large	AN080JSKLKN/EU
Commercial ERV	Large	AN100JSKLKN/EU

※ When ANxxxJSKLKN/EU is installed in a country which is subject to Commission regulation (EU) No 1253/2014 implementing Directive 2009/125/EC of the European Parliament and of the Council with regard to Ecodesign requirements for ventilation units, be sure to install a differential pressure switch (MOS-P1050), which can measure pressures at the front and back of the filter, together with the product.



12. MERV Filter MF-C6A0 for North America 4Way Cassette

12.1 Feature

Keep your place cleaner and healthier

Samsung high performance MERV Filter kit improve the quality of indoor air, maintain HVAC condition of commercial & residential buildings.

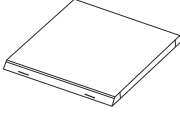
- MERV 13 rated
- Compatible with AM***FN4DCH/AA / AM***NN4DCH/AA

Name	MERV Filter	Installation manual
Quantity	12	1
Shape		

Dimension

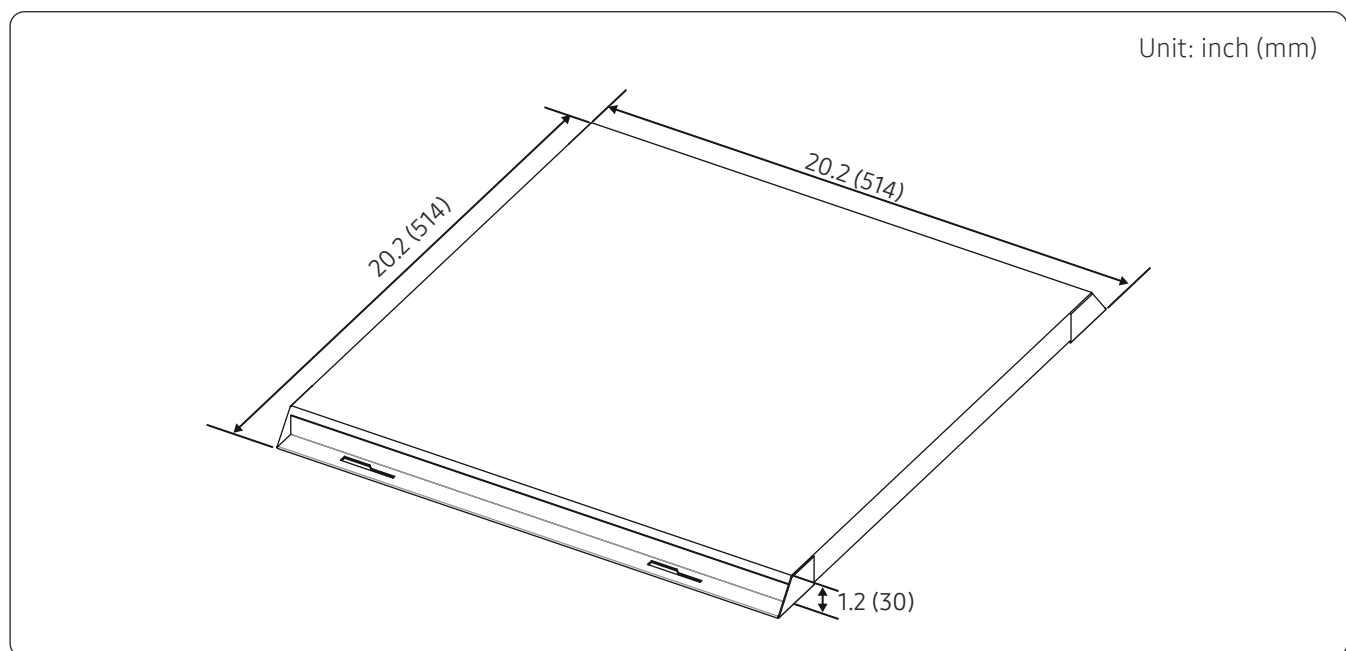

12. MERV Filter MF-C6A0 for North America 4Way Cassette

12.2 Installation

CAUTION

- The MERV filter is an optional component that is installed separately after installing an indoor unit on the ceiling.
- Handle with extreme care: Do not apply excessive force to the MERV filter.
This action may break the filter.
When moving or handling with the MERV filter, be careful not to damage the filter with any sharp objects.
- Install with extreme care: When installing the MERV filter on a high ceiling place, take extra care for safety accidents.

1 Open the indoor unit panel and remove the preinstalled filter from the indoor unit.

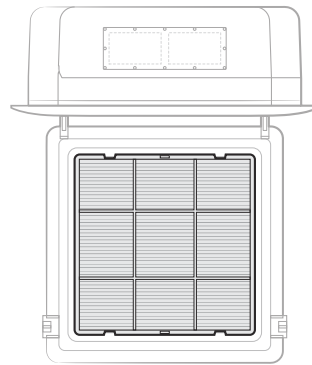

2 Install the MERV filter onto the specified position by using the Clips on the panel.

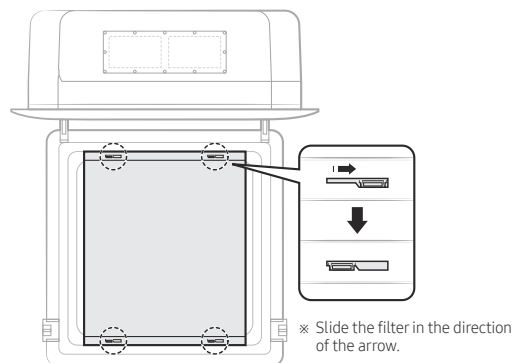

3 Close the indoor unit panel.

12. MERV Filter MF-C6A0 for North America 4Way Cassette

12.3 Setting the operating options for the MERV Filter

- The MERV filter is an optional component, therefore the factory default indoor unit setting must be modified to use the MERV filter. The option settings for using the MERV filter can be found in the table below.
- When using a wireless controller to program the indoor unit, input the option setting code more than two times to ensure proper programming.
- The performance of the indoor unit may differ depending on the option code that is applied.
- When the “Step2” option is applied, the minimum circuit ampacity (MCA) of the indoor unit can increase by up to 1.5 times. This needs to be considered when selecting power supply wire.

	Classification	AM009FN4DCH/AA	AM012FN4DCH/AA	AM018FN4DCH/AA	AM024FN4DCH/AA	AM030FN4DCH/AA	AM036FN4DCH/AA	AM048FN4DCH/AA
Option code	MERV13 (Spec)	01404F-1950CA-201A1A-330000	01404F-1950CA-202323-330000	01404F-1950CA-203434-330000	01404F-1950EA-204848-330000	01404F-19541F-205A5A-330020	01404F-19542F-206E6E-330020	01404F-195550-209191-330020
	MERV13 (Step1)	01404F-1950DA-201A1A-330000	01404F-1950DA-202323-330000	01404F-1950DA-203434-330000	01404F-19540A-204848-330000	01404F-19545F-205A5A-330020	01404F-195560-206E6E-330020	01404F-195573-209191-330020
	MERV13 (Step2)	01404F-1950EA-201A1A-330000	01404F-1950EA-202323-330000	01404F-1950EA-203434-330000	01404F-19541A-204848-330000	01404F-19548F-205A5A-330020	01404F-195591-206E6E-330020	01404F-195596-209191-330020

	Classification	AM009NN4DCH/AA	AM012NN4DCH/AA	AM018NN4DCH/AA	AM024NN4DCH/AA	AM030NN4DCH/AA	AM036NN4DCH/AA	AM048NN4DCH/AA
Option code	MERV13 (Spec)	01404F-1950CA-201A1A-330000	01404F-1950CA-202323-330000	01404F-1950CA-203434-330000	01404F-1950EA-204848-330000	01404F-19541F-205A5A-330020	01404F-19542F-206E6E-330020	01404F-195550-209191-330020
	MERV13 (Step1)	01404F-1950DA-201A1A-330000	01404F-1950DA-202323-330000	01404F-1950DA-203434-330000	01404F-19540A-204848-330000	01404F-19545F-205A5A-330020	01404F-195560-206E6E-330020	01404F-195550-209191-330021
	MERV13 (Step2)	01404F-1950EA-201A1A-330000	01404F-1950EA-202323-330000	01404F-1950EA-203434-330000	01404F-19541A-204848-330000	01404F-19548F-205A5A-330020	01404F-195591-206E6E-330020	01404F-195550-209191-330024

12. MERV Filter MF-C6A0 for North America 4Way Cassette

12.4 Air flow and Sound Data

AM009FN4DCH/AA / AM009NN4DCH/AA

Air Volume (CFM)

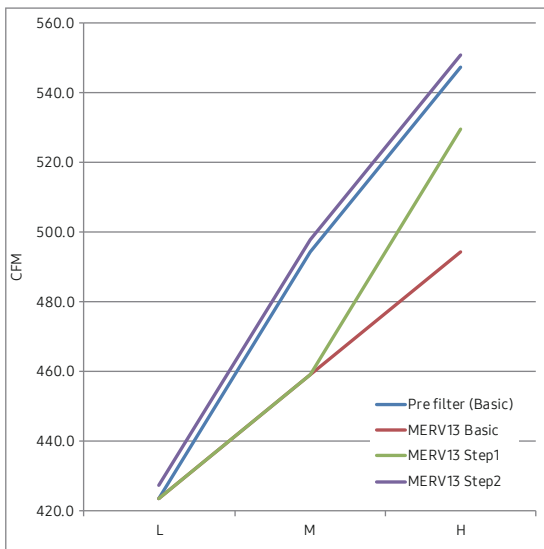

Sound Pressure (dBA)

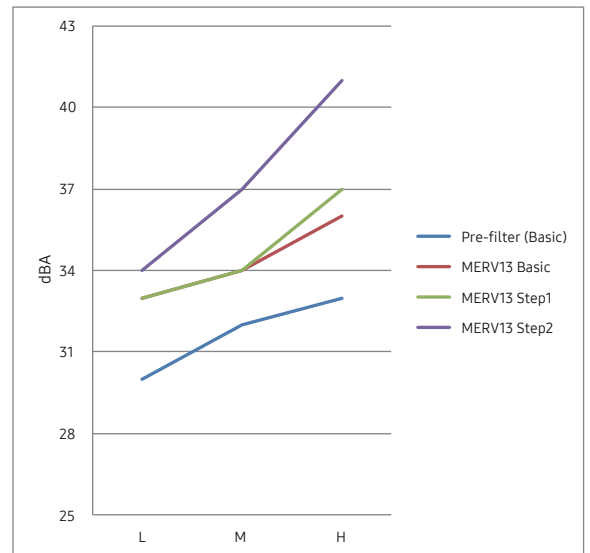

AM012FN4DCH/AA / AM012NN4DCH/AA

Air Volume (CFM)

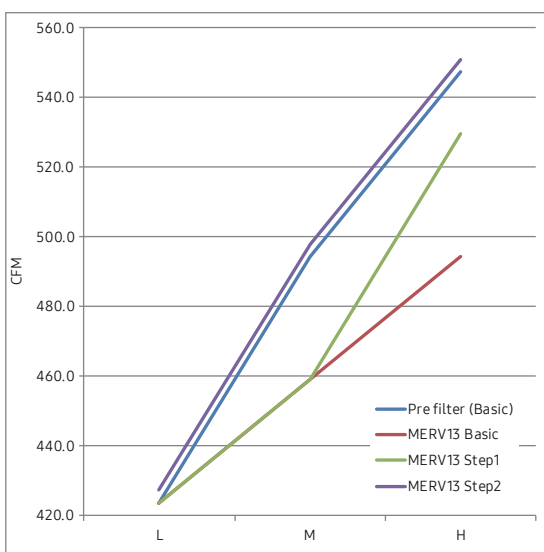

Sound Pressure (dBA)

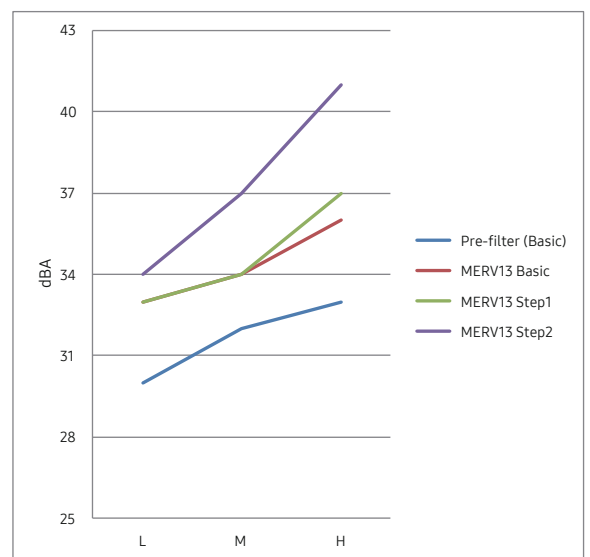

12. MERV Filter MF-C6A0 for North America 4Way Cassette

12.4 Air flow and Sound Data

AM018FN4DCH/AA / AM018NN4DCH/AA

Air Volume (CFM)

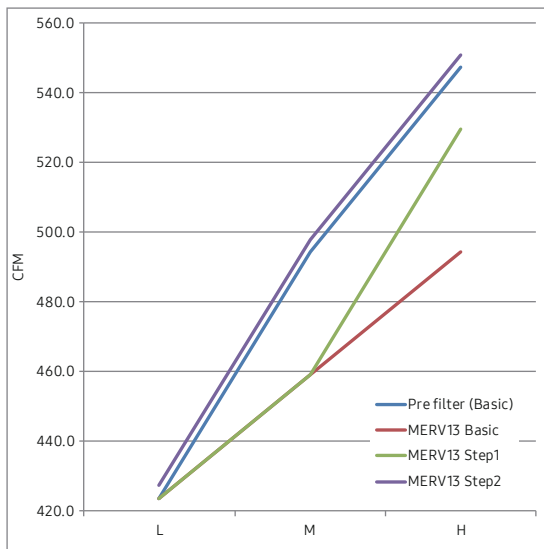

Sound Pressure (dBA)

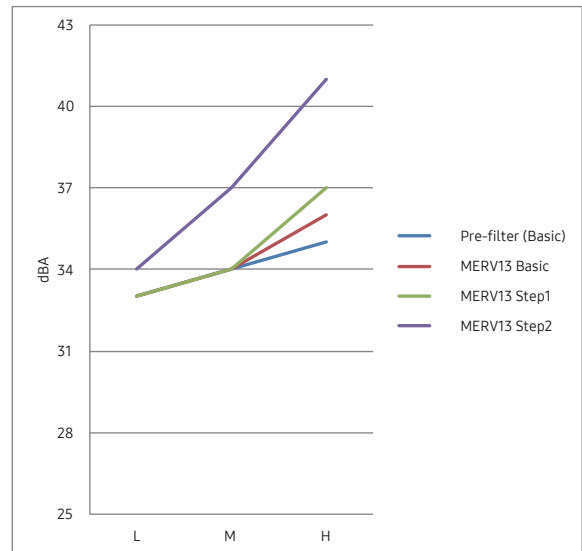

AM024FN4DCH/AA / AM024NN4DCH/AA

Air Volume (CFM)

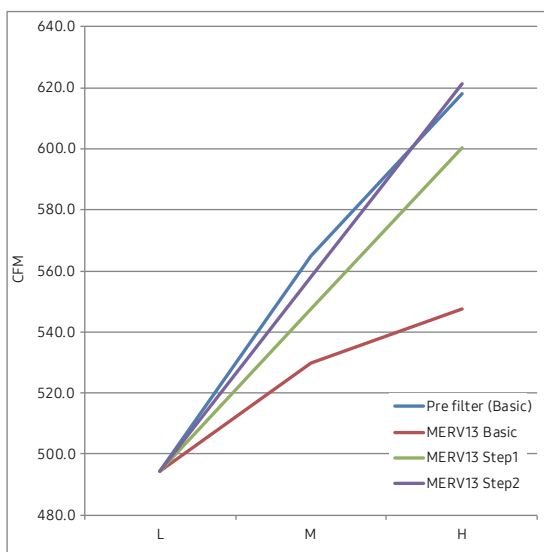

Sound Pressure (dBA)

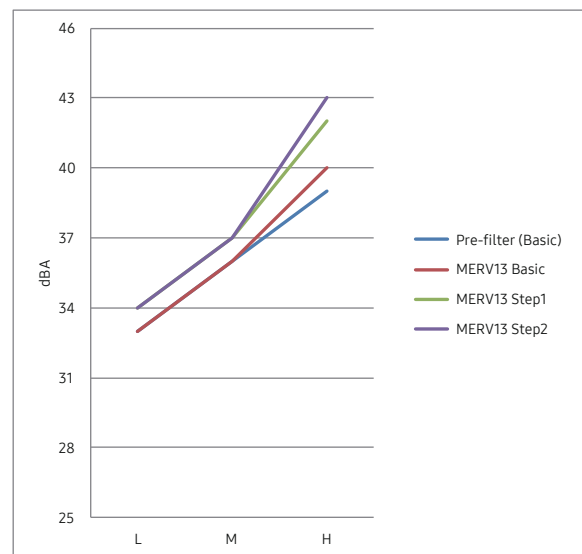

12. MERV Filter MF-C6A0 for North America 4Way Cassette

12.4 Air flow and Sound Data

AM030FN4DCH/AA / AM030NN4DCH/AA

Air Volume (CFM)

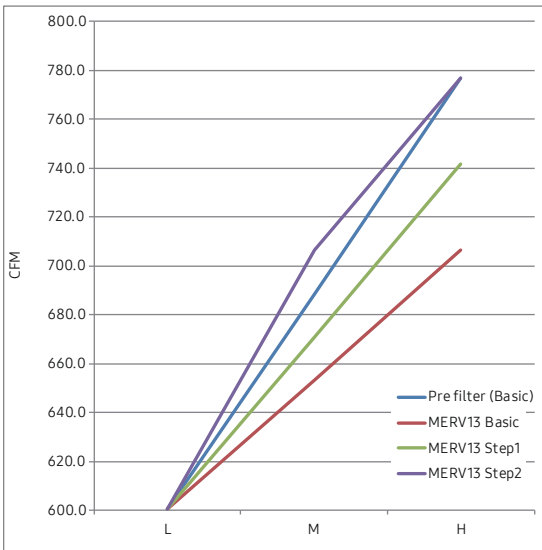

Sound Pressure (dBA)

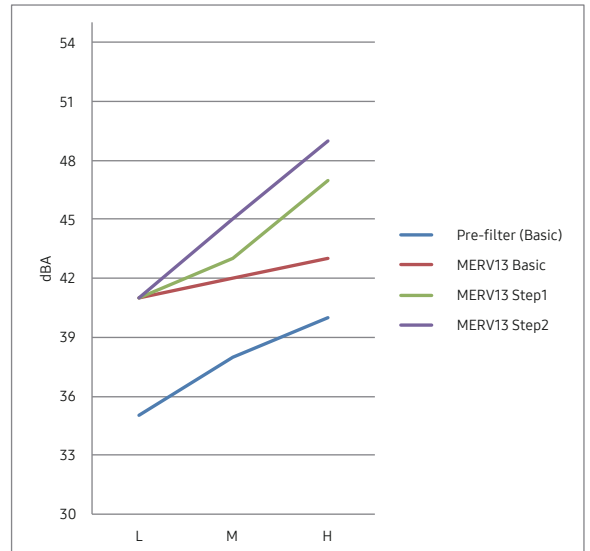

AM036N4DCH/AA / AM036NN4DCH/AA

Air Volume (CFM)

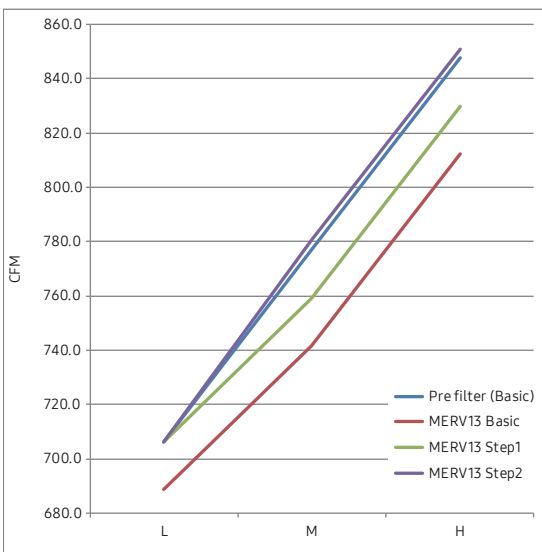

Sound Pressure (dBA)

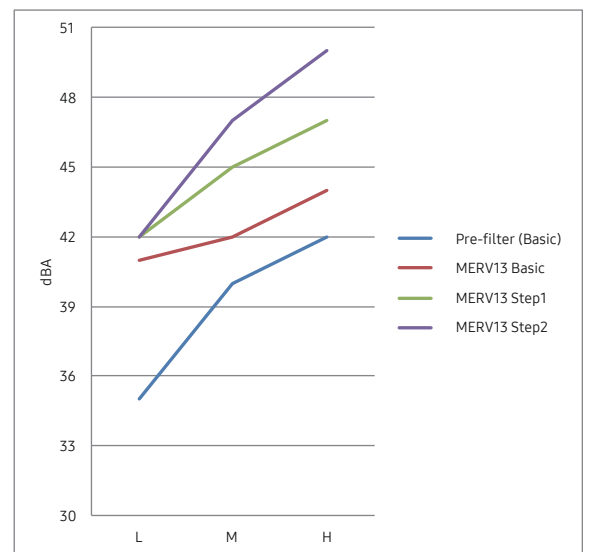

12. MERV Filter MF-C6A0 for North America 4Way Cassette

12.4 Air flow and Sound Data

AM048FN4DCH/AA / AM048NN4DCH/AA

Air Volume (CFM)

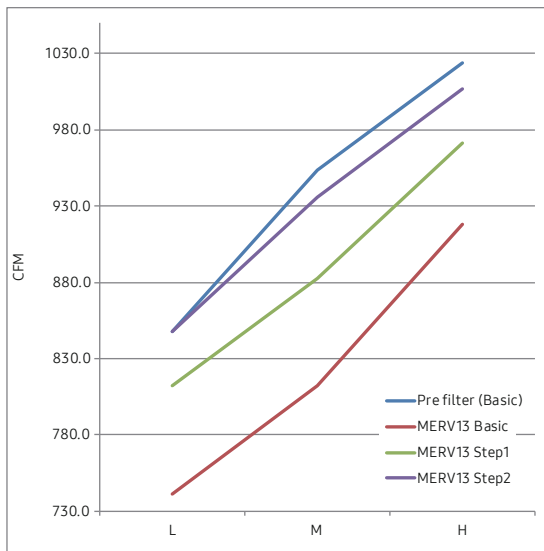

Sound Pressure (dBA)

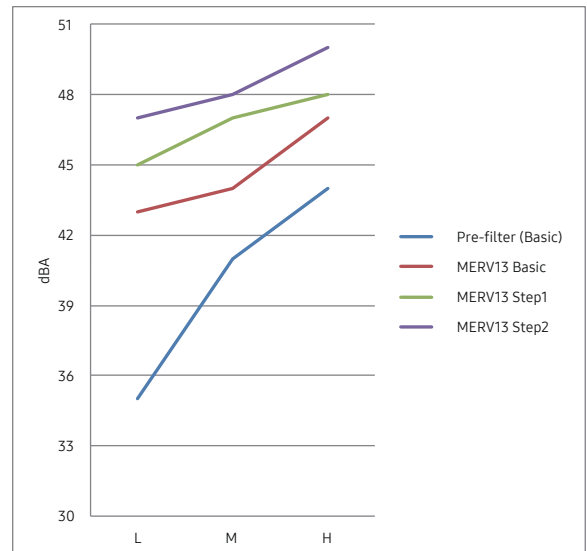

13. Accessory Compatibility

13.1. Indoor Unit's Accessory Compatibility

Product	Model	Remark	1way		2way	4way	360 Circle	360 Square	Mini 4way	Wind-Free Mini 4way	Slim duct	MSP Duct				Duct-5	Big Duct	OAP DUCT		PAC	Ceiling	P-Ceiling	Console	PAC	Floor Standing	ERV Plus	AHU	Local ERV (North America)
			JSF-0	JSF-1								JSF-2	MSP-5	MSP-0	MSP-1			MSP-2	SHF									
MCU-KIT	MCU-S6NEE1N	Below 6 indoor units, below 56 kW	0	0	0	0	0	0	0	0	0	0	0	0	0	0	0	0	0	0	0	0	0	0	0	0	0	
	MCU-S4NEE1N	Below 4 indoor units, below 56 kW	0	0	0	0	0	0	0	0	0	0	0	0	0	0	0	0	0	0	0	0	0	0	0	0	0	
	MCU-S4NEE2N	Below 2 large capacity indoor unit, below 56 kW	0	0	0	0	0	0	0	0	0	0	0	0	0	0	0	0	0	0	0	0	0	0	0	0	0	
	MCU-S2NEK1N	Below 2 indoor units, below 28 kW	0	0	0	0	0	0	0	0	0	0	0	0	0	0	0	0	0	0	0	0	0	0	0	0	0	
EEVKITS	MEV-E**SA	1 Indoor																	0									
	MXD-E**K***A	2,3 Indoor																	0									
AHU-KIT	MXD-K025AN	only for 2.5Hp's AHU																									0	
	MXD-K050AN	only for 5Hp's AHU																									0	
	MXD-K075AN	only for 7.5Hp's AHU																									0	
	MXD-K100AN	only for 10Hp's AHU																									0	
	MCM-D201N	only for 10~40Hp's AHU																									0	
DRAIN PUMP	MDP-N047SNCOD	-															0											
	MDP-N047SNC1D	-															0											
	MDP-M075SGU1D	-										0	0															
	MDP-M075SGU2D	-											0															
	MDP-M075SGU3D	-									0																	
	MDP-E075SEE3D	-									0																	
	MDP-G075SP	External, All Capacities															0											
	MDP-G075SQ	Internal														0												
Motion detect Sensor	MCR-SMA	No technical data provided							0																			
	MCR-SMC	No technical data provided				0																						
	MCR-SMD	No technical data provided							0																			
	MCR-SME	No technical data provided						0																				
S-Plasma Ion KIT	MSD-CAN1	No technical data provided				0	0	0	0	0											0							
	MSD-EAN1	No technical data provided												0	0		0								0			
ERV CO ₂ Sensor	MOS-C1	No technical data provided																							0			
ERV Kit	MXD-K200VN																									0		
Differential Pressure Switch	MOS-P1050																									0		
MERV Filter	MF-C6A0					0																						

NOTE

- In case you want to know information the accessories, please refer to the control and accessories TDB on pvi.samsung.com site.
- MERV Filter is applicable only to North America model: AM***FN4DCH/AA, AM***NN4DCH/AA

2022. 01
Ver.4.2

Samsung Electronics Co., LTD.

Head Office (Suwon Korea) 129, Samsung-Ro, Yeongtong-Gu, Suwon City, Gyeonggi-Do, Korea 16677
Website : www.samsung.com, <https://partnerhub.samsung.com> Email : airconditioner@samsung.com
Images and data in this book may subject to change without prior notice.