

Air conditioner

Installation manual

Distributor Kit MXD-E24K Series / MXD-E32K Series

- Thank you for purchasing this Samsung Product.
- Before operating this unit, please read this installation manual carefully and retain it for future reference.



DB68-03757A-05

SAMSUNG

Preparation for Installation

Unit : mm(inch)

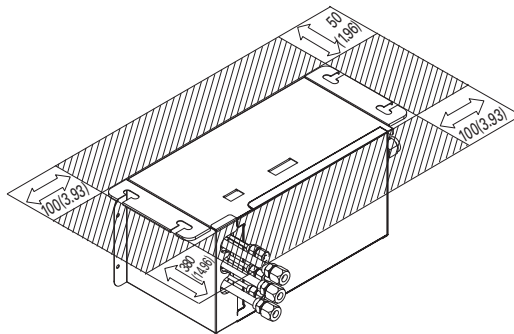
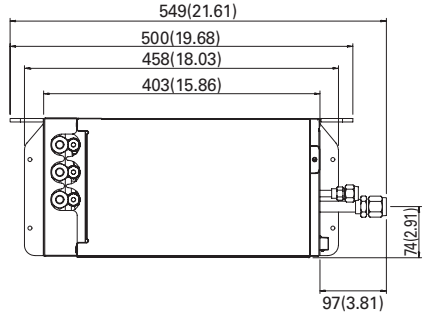
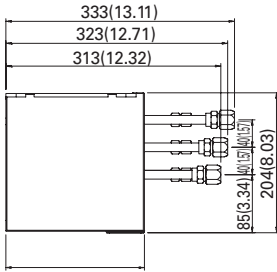
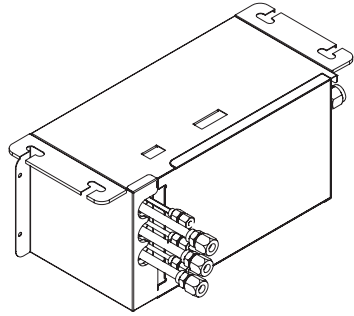
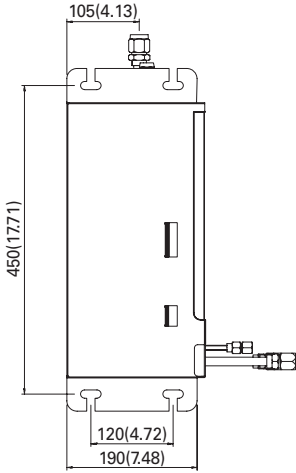

Inspection area

Electronic Expansion Valve Kit Installation

Connection of refrigerant piping & Installation

1. Decide an installation place that can support the electronic expansion valve kit.

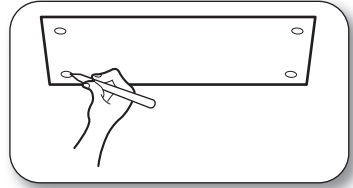

2. Connect the "IN" refrigerant pipe to the outdoor unit.

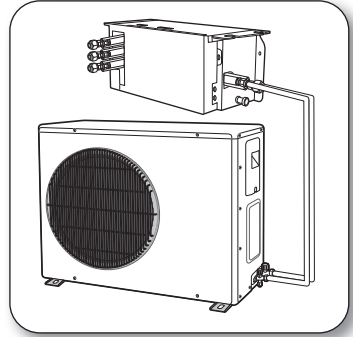

3. Connect the "OUT" refrigerant pipe to each indoor unit (A, B and C).
 - ▶ The liquid and gas pipes should not be crossed when piping connection.

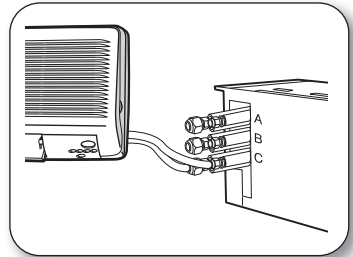

4. Insulate the connection piping. A joint part of pipe needs double thickness of insulation.

5. The expansion valve has to be installed that the user has no access to it.

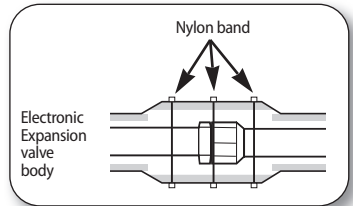

Electronic Expansion Valve Kit Installation (cont.)

Wiring & Assigning address

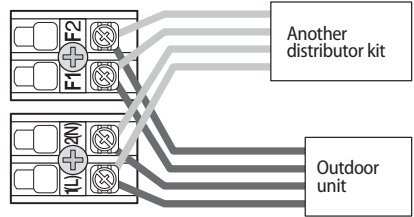
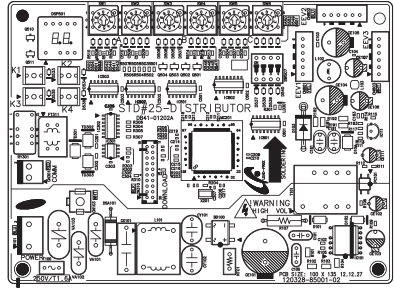
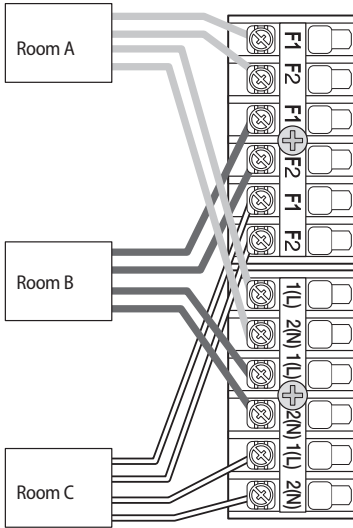

1. Connect the AC power cable and communication cable from the outdoor unit to terminal, then connect the cable to another electronic expansion valve kit.
2. Connect the AC power cable and communication cable to each indoor unit (A, B and C).
3. Align the SW01/SW02, SW03/SW04 and SW05/SW06's addresses with A, B and C indoor units'.

Switch No.	Appropriate indoor unit (Electronic expansion valve)	Connector No.
SW01/SW02	A	EEV.1 CN801(YELLOW)
SW03/SW04	B	EEV.2 CN802(BLUE)
SW05/SW06	C	EEV.3 CN803(WHITE)

Function of Display

- ▶ The numbers which is displayed on left are the status of indoor unit checking status through communication with same outdoor unit. (If it indicates 1, 3 and 7 that means the ADDRESS of indoor unit is set to 1, 3 and 7.)
- ▶ The numbers which is displayed on right indicate the ADDRESS of SW01/SW02, SW03/SW04 and SW05/SW06 in sequential. (If it indicates 0, 1 and 2 that means the SW01/SW02 is set to 0, the SW03/SW04 is set to 1, and the SW05/SW06 is set to 2.)
- ▶ If the communication error occurs in distributor, the Er↔C0 message will be shown on the display alternatively.

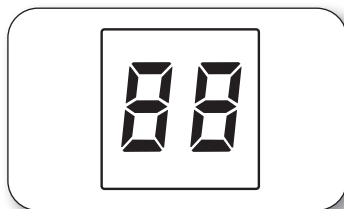

KEY function

- ▶ If you press a KEY on the PCB, the display will show you a step of appropriate electronic expansion valve.

KEY No.	Meaning	Example
K1	Step of electronic expansion valve A	19 (19 x 10 = 190 STEP)
K2	Step of electronic expansion valve B	
K3	Step of electronic expansion valve C	
K4	-	-

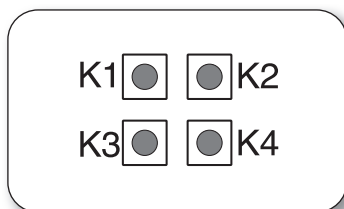

Applicable capacity

Model	A	B	C	Refrigerant
MXD-E24K132*	1.5 ~ 4.5 kW (7000 ~ 15500 Btu/h)	5 ~ 9 kW (17000 ~ 31000 Btu/h)	-	R-410A
MXD-E24K200*	1.5 ~ 4.5 kW (7000 ~ 15500 Btu/h)	1.5 ~ 4.5 kW (7000 ~ 15500 Btu/h)	-	
MXD-E24K232*	1.5 ~ 4.5 kW (7000 ~ 15500 Btu/h)	1.5 ~ 4.5 kW (7000 ~ 15500 Btu/h)	5 ~ 9 kW (17000 ~ 31000 Btu/h)	
MXD-E24K300*	1.5 ~ 4.5 kW (7000 ~ 15500 Btu/h)	1.5 ~ 4.5 kW (7000 ~ 15500 Btu/h)	1.5 ~ 4.5 kW (7000 ~ 15500 Btu/h)	
MXD-E32K200*	5 ~ 9 kW (17000 ~ 31000 Btu/h)	5 ~ 9 kW (17000 ~ 31000 Btu/h)	-	
MXD-E32K224*	5 ~ 9 kW (17000 ~ 31000 Btu/h)	5 ~ 9 kW (17000 ~ 31000 Btu/h)	1.5 ~ 4.5 kW (7000 ~ 15500 Btu/h)	
MXD-E32K300*	5 ~ 9 kW (17000 ~ 31000 Btu/h)	5 ~ 9 kW (17000 ~ 31000 Btu/h)	5 ~ 9 kW (17000 ~ 31000 Btu/h)	

合格证

检验员：_____

三星电子株式会社

三星全球服务网

如果您对三星产品有任何咨询或建议，请联系三星客服中心

服务热线：400-610-5858

网址：<https://www.samsung.com/cn>

联系地址：北京市朝阳区利泽中园101号启明国际大厦M层
三星（中国）投资有限公司

邮 编：100102

制 造 商：三星电子株式会社

原 产 地：韩国

销售商名称：三星（中国）投资有限公司

销售商地址：北京市朝阳区望京东园四区2号中航资本大厦19F

